

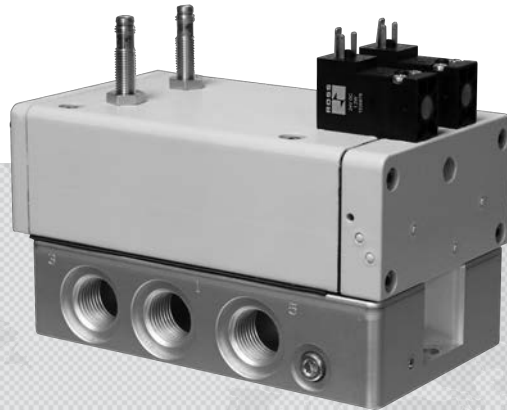

PRODUCT INFORMATION

SAFE CYLINDER RETURN DOUBLE VALVES

RSe SERIES



ROSS CONTROLS

Control Reliable Double Valves for External Monitoring

RSe Series Safe Cylinder Return

5/2 Redundant Double Valve – Sub-base Mounted

HOW TO ORDER

Choose your options (in red) to configure your valve model number.

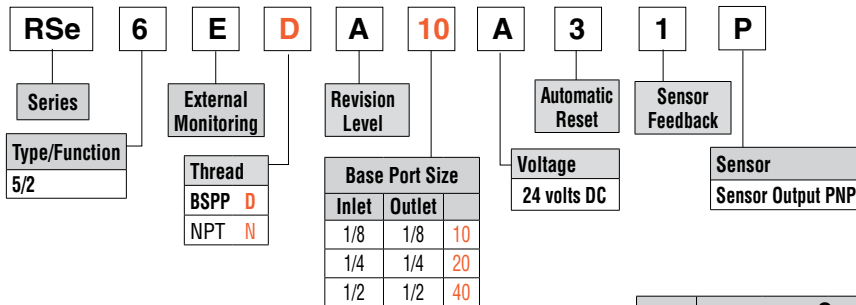

Port Size	C _v				Weight lb (Kg)
	1-2	1-4	2-3	4-5	
1/8	0.85	0.58	0.49	0.75	2.9 (1.3)
1/4	0.98	0.79	0.69	0.85	3.7 (1.7)
1/2	2.07	1.54	1.51	1.81	6.6 (2.99)



(Certifications pending)

F4

The 5/2 RSe Series valve is designed to control the direction of air flow into and out of a double-acting cylinder or other pneumatic actuator in order to drive the cylinder forward or backward to suit the requirements of the machine operation. However, the RSe Series does this with the same level of control expected of the machine's/system's safety circuit. The safety function of the RSe Series valve is to return the cylinder/actuator to its home "safe" position whenever a fault occurs within the valve. Such a monitoring system must be capable of inhibiting the operation of the valve.

The RSe Series valves are designed for external monitoring for safe, redundant operation of the valves. The RSe Series valves are constructed of redundant, spool type valves, and have an overall function of a single solenoid pilot-operated, spring return valve. Each single valve in the RSe Series is equipped with a PNP proximity sensor. Monitoring both of these sensors on each actuation and de-actuation of the RSe Series valve provides a diagnostic coverage of 99%. Monitoring of these sensors is to be done by an external monitoring system.

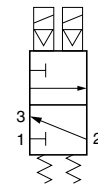

Simplified Schematics

F

An Integration Guide for the RSe Series Valves is available from ROSS to provide information such as operation, monitoring, and integration into users control circuits. Please follow link to access the [5/2 RSe Series Valves Integration Guide](#).

STANDARD SPECIFICATIONS (for valves on this page):

Construction Design	Spool and Sleeve	Temperature	Ambient/Media: 40° to 120°F (4° to 50°C)
Actuation	Solenoid pilot operated with air assisted spring return One solenoid per valve element (2 total) – both to be operated synchronously	Flow Media	Compressed, filtered air according to ISO 8573-1 Class 7:4:4
Mounting	Type: Base Orientation: Any, preferably vertical	Pilot Supply	Internal or External
Solenoids	Version as per VDE 0580. Rated for continuous duty	Operating Pressure	With Internal Pilot Supply: 43 to 145 psig (3 to 10 bar) With External Pilot Supply: 0 to 145 psig (0 to 10 bar) Pilot Supply - <i>When external pilot supply, pressure must be equal to or greater than inlet pressure.</i>
Enclosure Rating	DIN 400 50 IP 65	Monitoring	Dynamic, cyclical, external with customer supplied equipment. Monitoring should check state of both valve position sensors with any and all changes in state of valve control signals.
Electrical Connection	Connector Socket according to EN 175301-803 Form C	Minimum Operation Frequency	Once per month, to ensure proper function
Voltage	24 volts DC	Construction Material	Valve Body: Cast Aluminum Spool: Stainless Steel Seals: Buna-N
Power Consumption (each solenoid)	1.2 watts on DC	<i>Pending</i> Functional Safety Data	
Proximity Sensors (2 per valve)	PNP		
Current Consumption (each sensor)	<23mA		

These valves are not designed for controlling clutch/brake mechanisms on mechanical power presses.

IMPORTANT NOTE: Please read carefully and thoroughly all of the **CAUTIONS, WARNINGS** on the inside back cover.



Online Version
Rev. 08/07/18

rosscontrols.com

F4.3

Control Reliable Double Valves for External Monitoring

Safe Cylinder Return RSe Series

Valve Dimensions – inches (mm)

Port Size 1/8

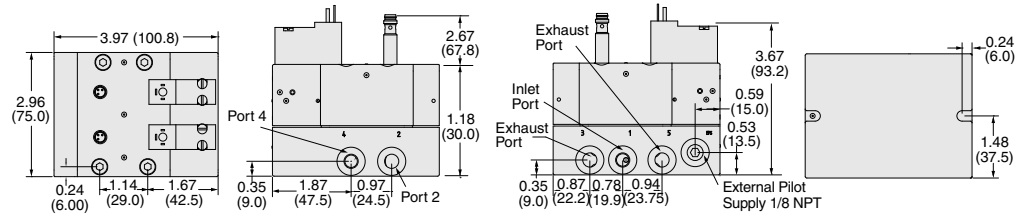

Port Size 1/4

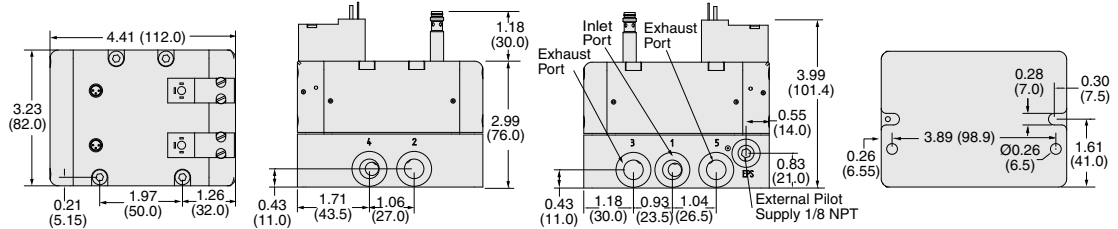

Port Size 1/2

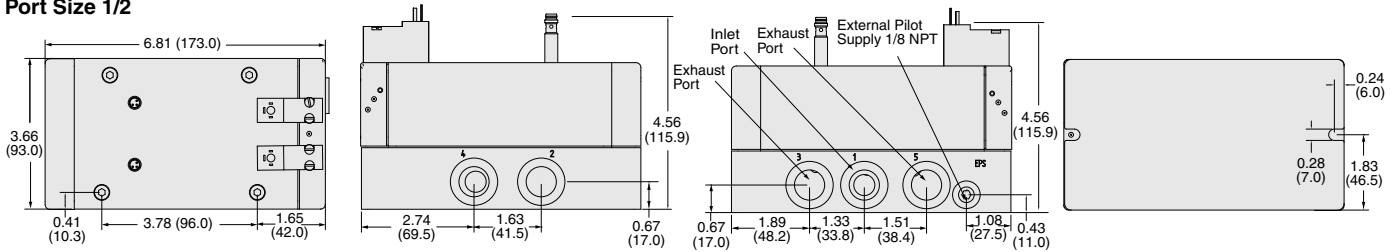

ACCESSORIES & OPTIONS

Silencers



Port Size	Thread Type	Model Number		Avg. C _v	Dimensions inches (mm)		Weight lb (kg)
		NPT Threads	BSPT Threads		Width	Length	
1/8	Male	5500A1003	D5500A1003	1.2	0.9 (21)	2.0 (51)	0.1 (0.1)
1/4	Male	5500A2003	D5500A2003	2.1	0.9 (21)	2.2 (55)	0.1 (0.1)
1/2	Male	5500A4003	D5500A4003	4.7	1.3 (32)	3.6 (91)	0.2 (0.1)

Pressure Range: 0 to 290 psig (0 to 20 bar) maximum. **Flow Media:** Filtered air.

Electrical Connectors

Connection	Electrical Connector Form	Electrical Connector Type	Cord Length meters (feet)	Cord Diameter	Model Number	
					Without Light	Lighted Connector 24 Volts DC
Solenoid	DIN EN 175301-803 Form C	Prewired Connector (18 gauge)	3 (10)	8-mm	2449K77	2450K77-W
	DIN 43650 Form C	Connector Only	–	–	2452K77	2453K77-W
Feedback Sensor	M8 Connector (sensing)	Prewired Connector	2 (6.5)	–	249L74	–



CAUTIONS: Do not use electrical connectors with surge suppressors, as this may increase valve response time when de-actuating the solenoids.

Preassembled Wiring Kits

Connector Type	Length meters (feet)	Model Number*
		Lighted Connector
EN 175301-803 Form C (solenoids) M8 (sensors)	2 (6.5)	2657B77

* Each cable has one connector. Kits include 2 cables for the sensors (M8), and 2 cables (EN 175301-803 Form C) with connector plus a cord grip for each.

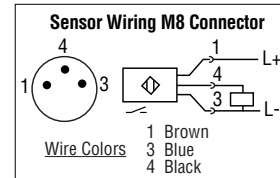
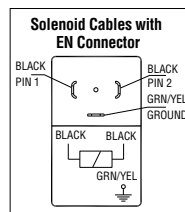

General Information

Standard Specifications

The standard specifications for the products on each page of this catalog are given on the same page or referenced. For solenoid pilot valves, models with internal pilot supply are listed. Most models are also available for use with external pilot supply or have a built-in pilot supply selector valve.

The products in this catalog are intended for use in industrial pneumatic systems. Most products are adaptable to other uses and conditions not covered by the standard specifications given in this catalog. Weights shown are approximate and are subject to change. Dimensions given, unless otherwise noted, are envelope dimensions (not for mounting). Consult ROSS for further information.

Port Threads

Ports of valves and bases described in this catalog have NPT (ANSI B2.1) threads. Other thread types can be specified by putting an appropriate prefix letter on the model number when ordering.

Thread Types by Model Prefix Letter

Pneumatic Port Threads	Prefix Letter	Threaded Electrical Opening
NPT (ANSI B2.1)	None	NPT
ISO 228 - DIN 259 Parallel, BSPP [#]	C*	—
ISO 228 - DIN 259 Parallel, BSPP [#]	D	G
ISO 228 - JIS B0203 Tapered [#]	J	ISO
SAE 1926- ISO 11926	S	NPT

* Used only for filters, regulators, lubricators.

[#] ISO 228 threads supersedes BSPP, G and JIS thread types.

Flow Ratings

Flow ratings are expressed as C_v where $C_v = 1$ corresponds to a steady state air flow of approximately 32 scfm under the following conditions:

Inlet pressure = 100 psig (6.7 bar)
Pressure drop = 10 psi (0.69 bar)
Air temperature = 68°F (20°C)
Relative humidity = 36%

Note: Because widely differing test standards are used to measure C_v values, the figures given in this catalog should not be used to compare ROSS valves with those of other makers. The C_v ratings given here are intended only for use with performance charts published by ROSS. The C_v ratings are averages for the various flow paths through the valve and are for steady flow conditions.

Approvals and Certifications

ROSS products are designed to meet a number of industrial standards, including the Canadian Standards Association (C.S.A.) guidelines. For more information on specific product approvals, contact your local distributor or ROSS.

Solenoids

All ROSS standard solenoids are rated for continuous duty (unless noted otherwise) and will operate the valve within the air pressure range specified in this catalog.

Explosion-Proof Solenoid Pilot available, for more information consult ROSS.

Voltage & Hertz

When ordering a solenoid valve, also specify the desired solenoid voltage and hertz.

Voltage Types by Model Suffix Letter

Voltage	Suffix Letter
120 volts AC	Z
220 volts AC	Y
12 volts DC	H
24 volts DC	W
48 volts DC	M
90 volts DC	K
110 volts DC	P
125 volts DC	C

Recommended Solenoid Voltages: 100-110 volts AC, 50 Hz; 100-120 volts AC, 60 Hz; 24 volts DC; 110 volts DC.

In addition, the following voltages are available:

200, 220 volts AC, 50 Hz
200, 240, 480 volts AC, 60 Hz
24, 48, 220 volts AC, 50 Hz
240 volts AC, 60 Hz
200, 220 volts AC, 50 Hz
200, 240 volts AC, 60 Hz.

For example: Model 2773B5001, 120 volts AC, 60 Hz.
Model W6076B2401, 220 volts AC, 50 Hz.

Please note that not all configurations are available for all models.

For additional information or help with voltage configuration, please contact your local distributor or ROSS.

Port Identification

Valve symbols in this catalog conform to the ISO 1219-1:1991 standard of the International Organization for Standardization (ISO) and the SAE J2051 standard of the Society of Automotive Engineers (SAE) respectively.

Information or Technical Assistance

For additional information or application assistance concerning ROSS products, consult ROSS or your local ROSS distributor (see contact information on the back cover).

Order Placement

For order placement, consult ROSS or your local ROSS distributor.
For a current list of countries and local distributors, visit ROSS' website at rosscontrols.com.

CAUTIONS, WARNINGS and STANDARD WARRANTY

PRE-INSTALLATION or SERVICE

1. Before servicing a valve or other pneumatic component, be sure that all sources of energy are turned off, the entire pneumatic system is shut off and exhausted, and all power sources are locked out (ref: OSHA 1910.147, EN 1037).
2. All ROSS products, including service kits and parts, should be installed and/or serviced only by persons having training and experience with pneumatic equipment. Because any installation can be tampered with or need servicing after installation, persons responsible for the safety of others or the care of equipment must check every installation on a regular basis and perform all necessary maintenance.
3. All applicable instructions should be read and complied with before using any fluid power system in order to prevent harm to persons or equipment. In addition, overhauled or serviced valves must be functionally tested prior to installation and use. If you have any questions, call your nearest ROSS location listed on the cover of this document.
4. Each ROSS product should be used within its specification limits. In addition, use only ROSS parts to repair ROSS products.

WARNING: *Failure to follow these directions can adversely affect the performance of the product or result in the potential for human injury or damage to property.*

FILTRATION and LUBRICATION

5. Dirt, scale, moisture, etc. are present in virtually every air system. Although some valves are more tolerant of these contaminants than others, best performance will be realized if a filter is installed to clean the air supply, thus preventing contaminants from interfering with the proper performance of the equipment. ROSS recommends a filter with a 5-micron rating for normal applications.
6. All standard ROSS filters and lubricators with polycarbonate plastic bowls are designed for compressed air applications only. Do *not* fail to use the metal bowl guard, where provided, to minimize danger from high pressure fragmentation in the event of bowl failure. Do not expose these products to certain fluids, such as alcohol or liquefied petroleum gas, as they can cause bowls to rupture, creating a combustible condition, hazardous leakage, and the potential for human injury or damage to property. Immediately replace a crazed, cracked, or deteriorated bowl. When bowl gets dirty, replace it or wipe it with a clean dry cloth.

7. Only use lubricants which are compatible with materials used in the valves and other components in the system. Normally, compatible lubricants are petroleum based oils with oxidation inhibitors, an aniline point between 180°F (82°C) and 220°F (104°C), and an ISO 32, or lighter, viscosity. Avoid oils with phosphate type additives which can harm polyurethane components, potentially leading to valve failure which risks human injury, and/or damage to property.

AVOID INTAKE/EXHAUST RESTRICTION

8. Do not restrict the air flow in the supply line. To do so could reduce the pressure of the supply air below the minimum requirements for the valve and thereby cause erratic action.
9. Do not restrict a valve's exhaust port as this can adversely affect its operation. Exhaust silencers must be resistant to clogging and must have flow capacities at least as great as the exhaust capacities of the valves. Contamination of the silencer can result in reduced flow and increased back pressure.

WARNING: *ROSS expressly disclaims all warranties and responsibility for any unsatisfactory performance or injuries caused by the use of the wrong type, wrong size, or an inadequately maintained silencer installed with a ROSS product.*

POWER PRESSES

10. Mechanical power presses and other potentially hazardous machinery using a pneumatically controlled clutch and brake mechanism must use a press control double valve with a monitoring device. A double valve without a self-contained monitoring device should be used only in conjunction with a control system which assures monitoring of the valve. All double valve installations involving hazardous applications should incorporate a monitoring system which inhibits further operation of the valve and machine in the event of a failure within the valve mechanism.

ENERGY ISOLATION/EMERGENCY STOP

11. Per specifications and regulations, ROSS L-O-X® and L-O-X® with EEZ-ON® operation products are defined as energy isolation devices, NOT AS EMERGENCY STOP DEVICES.

STANDARD WARRANTY

limited to repair or replacement of the product or refund of the purchase price paid solely at the discretion of ROSS and provided such product is returned to ROSS freight prepaid and upon examination by ROSS is found to be defective. This warranty becomes void in the event that product has been subject to misuse, misapplication, improper maintenance, modification or tampering.

THE WARRANTY EXPRESSED ABOVE IS IN LIEU OF AND EXCLUSIVE OF ALL OTHER WARRANTIES AND ROSS EXPRESSLY DISCLAIMS ALL OTHER WARRANTIES EITHER EXPRESSED OR IMPLIED WITH RESPECT TO MERCHANTABILITY OR FITNESS FOR A PARTICULAR PURPOSE. ROSS MAKES NO WARRANTY WITH RESPECT TO ITS PRODUCTS MEETING THE PROVISIONS OF ANY GOVERNMENTAL OCCUPATIONAL SAFETY AND/OR HEALTH LAWS OR REGULATIONS. IN NO EVENT IS ROSS LIABLE TO PURCHASER, USER, THEIR EMPLOYEES OR OTHERS FOR INCIDENTAL OR CONSEQUENTIAL DAMAGES WHICH MAY RESULT FROM A BREACH OF THE WARRANTY DESCRIBED ABOVE OR THE USE OR MISUSE OF THE PRODUCTS. NO STATEMENT OF ANY REPRESENTATIVE OR EMPLOYEE OF ROSS MAY EXTEND THE LIABILITY OF ROSS AS SET FORTH HEREIN.

All products sold by ROSS CONTROLS are warranted for a one-year period [with the exception of all Filters, Regulators and Lubricators ("FRLs") which are warranted for a period of seven years] from the date of purchase to be free of defects in material and workmanship. ROSS' obligation under this warranty is





AMERICAS

U.S.A.

ROSS CONTROLS

rosscontrols.com

Customer Service

1-800-GET-ROSS (438-1800)

Technical Service

1-888-TEK-ROSS (835-7677)

Canada

ROSS CANADA

rosscanada.com

6077170 CANADA INC.

AN INDEPENDENT REPRESENTATIVE

Brazil

ROSS SOUTH AMERICA Ltda.

rosscontrols.com.br

EUROPE

Germany

ROSS EUROPA GmbH

rosseuropa.com

United Kingdom

ROSS UK Ltd.

+44-1543-671495

sales.uk@rosscontrols.com

rossuk.co.uk

France

ROSS FRANCE SAS

rossfrance.com

ASIA & PACIFIC

Japan

ROSS ASIA K.K.

rossasia.co.jp

India

ROSS CONTROLS INDIA Pvt. Ltd.

rosscontrols.com

China

ROSS CONTROLS (CHINA) Ltd.

rosscontrolschina.com

Full-Service Global Locations

There are ROSS Distributors Throughout the World

To meet your requirements across the globe, ROSS distributors are located throughout the world. Through ROSS or its distributors, guidance is available for the selection of ROSS products, both for those using pneumatic components for the first time and those designing complex systems.

Other literature is available for engineering, maintenance, and service requirements.

If you need products or specifications not shown in this catalog, please visit ROSS' website, contact ROSS or your ROSS distributor. The ROSS Support Team will be happy to assist you in selecting the best product for your application.

For a current list of countries and local distributors, visit ROSS' at rosscontrols.com.