

Control Reliable Double Valves with Dynamic Monitoring & Memory

DM²® Series C Air Dump / Release

Basic Size 2, 4, 8, 12 and 30

Dynamic Monitoring With Complete Memory: Memory, monitoring, and air flow control functions are simply integrated into two identical valve elements. Valves lock-out due to asynchronous movement of valve elements during actuation or de-actuation, resulting in a residual outlet pressure of less than 1% of supply.

An Action is Required for Reset – cannot be reset by removing and re-applying supply pressure. Reset can only be accomplished by the optional integrated electrical (solenoid) reset.

Basic 3/2 Normally Closed Valve Function: Dirt tolerant, wear compensating poppet design for quick response and high flow capacity. PTFE back-up rings on pistons to enhance valve endurance – operates with or without inline lubrication.

Status Indicator: Includes a pressure switch with both normally open (NO) and normally closed (NC) contacts to provide status feedback to the control system indicating whether the valve is in the lockout or ready-to-run condition.

Silencers: All models include high flow, clog resistant silencers.

Mounting: Base mounted – with BSPP or NPT pipe threads. Inlet and outlet ports on both sides provide for flexible piping (plugs for unused ports included). Captive valve-to-base mounting screws.

Basic Size 12 and 30

Intermediate Pilots: Increases pilot air flow for fast valve response, making it possible to use the same size solenoids as valve sizes 2, 4 & 8, thereby reducing electrical power requirements for these larger valves.



ISO 13849-1:2006
Category 4 PL e
applications

(Basic Size 2
DGUV, CE
Certifications
pending)



HOW TO ORDER

(Choose your options (in red) to configure your valve model number.)

DM2C	N	A	4	2	A	2	1	
-------------	----------	----------	----------	----------	----------	----------	----------	--

Thread	BSPP D	NPT N
---------------	---------------	--------------

REVISION LEVEL	Size 4, 8, 12, 30 A	Size 2 B
-----------------------	----------------------------	-----------------

Basic Size	2 2	4 4	8 5	12 6	30 8
-------------------	------------	------------	------------	-------------	-------------

Base Port Size	2 1/4 inlet – 1/4 outlet 0	3/8 inlet – 3/8 outlet 1	4 1/2 inlet – 1/2 outlet 2	8 3/4 inlet – 3/4 outlet 4	1 inlet – 1 outlet 5	12 1 inlet – 1 outlet 6	30 1½ inlet - 2 outlet 8
-----------------------	-----------------------------------	---------------------------------	-----------------------------------	-----------------------------------	-----------------------------	--------------------------------	---------------------------------

Solenoid Reset Type	24 volts DC A	110 volts AC, 50 Hz B	120 volts AC, 50/60 Hz B
* For other voltages consult ROSS.			

Status Indicator	Yes 1	No X
-------------------------	--------------	-------------

Connection Type	EN 175301-803 Form A* Blank	M12 (connector included) 005
*See options for connectors or wiring kits.		

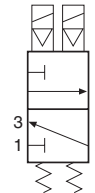

Simplified Schematic

Basic Size	Inlet Port Size	Cv		Weight lb (Kg)
		1-2	2-3	
2	1/4	1.67	2.61	5.3 (2.4)
2	3/8	2.17	2.61	5.3 (2.4)
4	1/2	3	10	5.9 (2.6)
8	3/4	4.2	13	8.4 (3.7)
8	1	4.4	13	8.4 (3.7)
12	1	8.5	20	15.3 (3.7)
30	1½	22	64	34.7 (15.1)

Valve and base assembly with status indicator.

Explosion proof solenoid pilot available, for more information consult ROSS.

STANDARD SPECIFICATIONS (for valves on this page):

Construction: Dual poppet.

Mounting Type: Base mounted.

Pilot Solenoids: According to VDE 0580. Enclosure rating according to DIN 400 50 IP 65. Three solenoids, rated for continuous duty.

Standard Voltages/Pilot Solenoids Power Consumption (each solenoid):

Basic Size 2, 4, 12 & 30:

Primary and reset solenoids:

24 volts DC; 110 volts AC, 50 Hz; 120 volts AC, 50/60 Hz.

5.8 watts nominal on AC and DC; 6.5 watts maximum on AC and DC.

Basic Size 8:

Primary solenoids: 15 watts on DC; 36 VA inrush and 24.6 VA holding on AC.

Reset solenoid: 6.0 watts on DC; 15.8 VA inrush and 10.4 VA holding on AC.

Enclosure Rating: IP65, IEC 60529.

Electrical Connection: EN 175301-803 Form A, or M12.

Ambient Temperature: 15° to 122°F (-10° to 50°C).

Media Temperature: 40° to 175°F (4° to 80°C).

Flow Media: Filtered, lubricated or unlubricated (mineral oils according to DIN 51519, viscosity classes 32-46).

Inlet Pressure: Basic Size 2: 45 to 150 psig (3.1 to 10.3 bar).

Basic Size 4, 8, 12, 30: 30 to 120 psig (2.1 to 8.3 bar).

Pressure Switch (Status Indicator) Rating: Contacts - 5 amps at 250 volts AC, or 5 amps at 30 volts DC.

Monitoring: Dynamically, cyclically, internally during each actuating and de-actuating movement. Monitoring function has memory and requires an overt act to reset unit after lockout.

Mounting Orientation: Preferably horizontally (valve on top of base) or vertically with pilot solenoids on top.

Functional Safety Data: Category 4 PL e; B10d: 20,000,000; PFHd: 7.71x10⁻⁹; MTTFd: 301.9 (n_{op}: 662400).

Certifications: CE Marked for applicable directives, DGUV Test, CSA/UL, TSSA for appropriately tested valves.

Vibration/Impact Resistance: Tested to BS EN 60068-2-27.

This valve is not designed for controlling clutch/brake mechanisms on mechanical power presses, see DM² series D for mechanical power press applications.

IMPORTANT NOTE: Please read carefully and thoroughly all of the **CAUTIONS, WARNINGS** on the inside back cover.

Control Reliable Double Valves with Dynamic Monitoring & Memory

DM^{2®} Series C Valve Technical Data

Valve Dimensions – inches (mm)

Basic Size 2

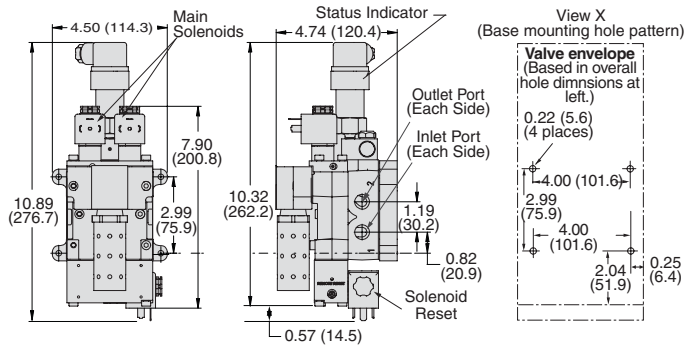

Basic Size 4

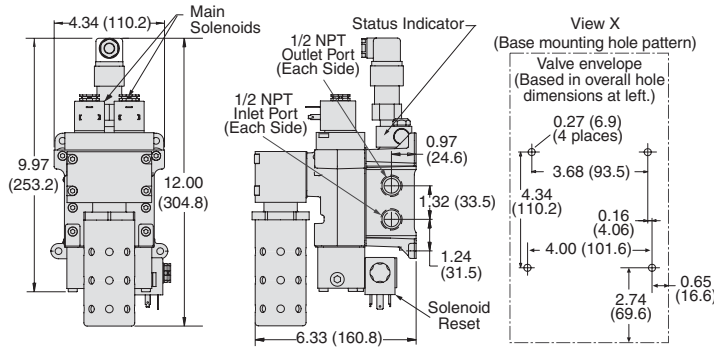

Basic Size 8

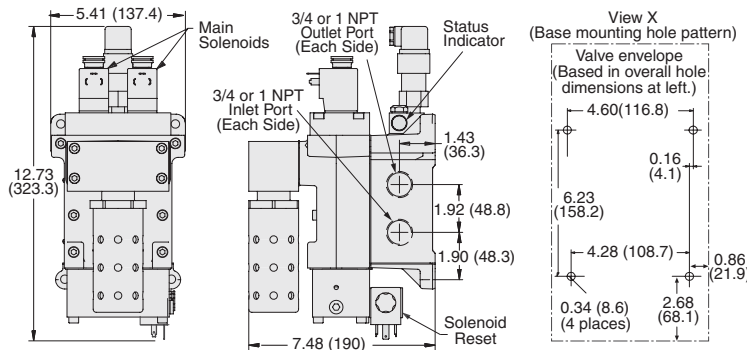

Basic Size 12

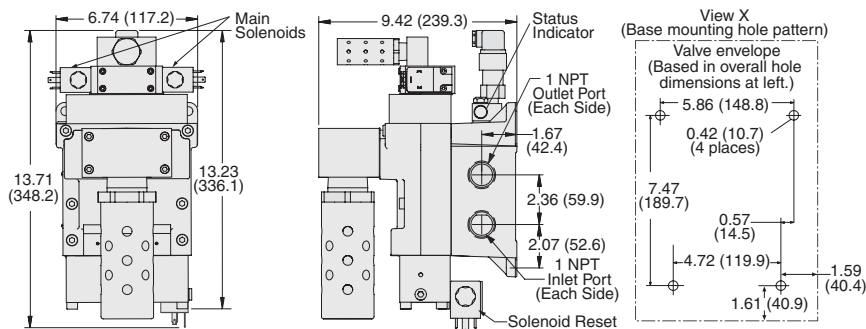

Basic Size 30

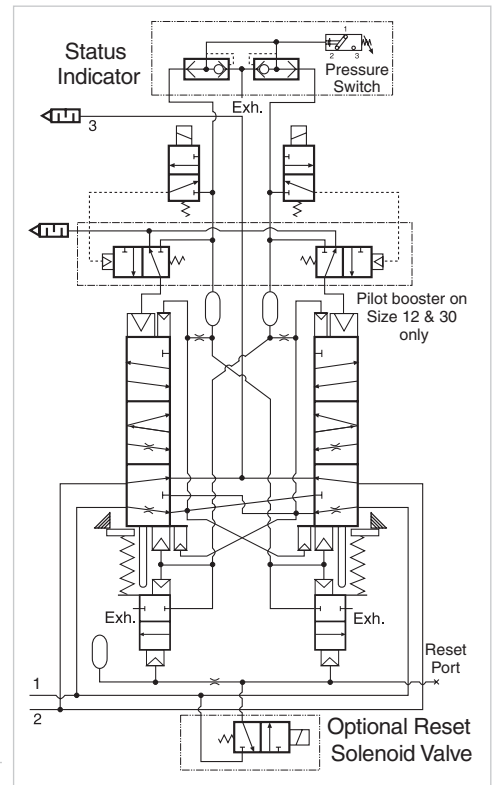
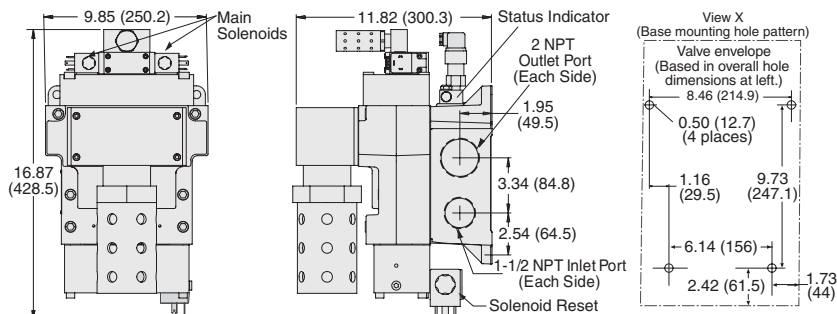

Schematic - Valve de-actuated

F3

F



Control Reliable Double Valves with Dynamic Monitoring & Memory

DM²® Series C Valve Operation

Valve de-actuated (ready-to-run): The flow of inlet air pressure into the crossover passages is restricted by the size of the passage between the stem and the valve body opening. Flow is sufficient to quickly pressurize pilot supply/timing chambers A and B. The inlet poppets prevent air flow from crossover passages into the outlet chamber. Air pressure acting on the inlet poppets and return pistons securely hold the valve elements in the closed position. (Air passages shown out of position and reset adapter omitted for clarity.)

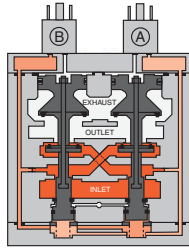

Valve actuated: Energizing the pilot valves simultaneously applies pressure to both pistons, forcing the internal parts to move to their actuated (open) position, where inlet air flow to crossover passages is fully open, inlet poppets are fully open and exhaust poppets are fully closed. The outlet is then quickly pressurized, and pressure in the inlet, crossovers, outlet, and timing chambers are quickly equalized. De-energizing the pilots quickly causes the valve elements to return to the ready-to-run position.

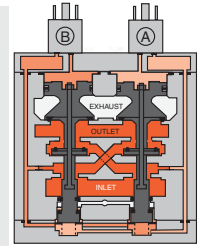

Valve locked-out: Whenever the valve elements operate in a sufficiently asynchronous manner, either on actuation or de-actuation, the valve will move to a locked-out position. In the locked-out position, one crossover and its related timing chamber will be exhausted, and the other crossover and its related timing chamber will be fully pressurized. The valve element (side B) that is partially actuated has pilot air available to fully actuate it, but no air pressure on the return piston to fully de-actuate the valve element. Air pressure in the crossover acts on the differential of side B stem diameters creating a latching force. Side A is in a fully closed position, and has no pilot air available to actuate, but has full pressure on the inlet poppet and return piston to hold the element in the fully closed position. Inlet air flow on side A into its crossover is restricted, and flows through the open inlet poppet on side B, through the outlet into the exhaust port, and from the exhaust port to atmosphere. Residual pressure in the outlet is less than 1% of inlet pressure. The return springs are limited in travel, and can only return the valve elements to the intermediate (locked-out) position. Sufficient air pressure acting on the return pistons is needed to return the valve elements to a fully closed position.

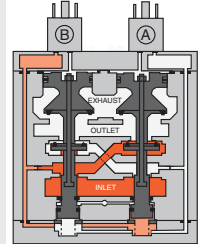

Resetting the valve: The valve will remain in the locked-out position, even if the inlet air supply is removed and re-applied. A remote reset signal must be applied to reset the valve. Reset is accomplished by momentarily pressurizing the reset port. Actuation of the reset piston physically pushes the main valve elements to their closed position. Inlet air fully pressurizes the crossovers and holds the inlet poppets on seat. Actuation of the reset piston opens the reset poppet, thereby, immediately exhausting pilot supply air, thus, preventing valve operation during reset (Reset adapter added to illustration.). De-actuation of reset pistons causes the reset poppets to close and pilot supply to fully pressurize. Reset pressure can be applied by a remote 3/2 normally closed valve, or from an optional 3/2 normally closed solenoid mounted on the reset adapter. De-actuation of reset pistons causes the reset poppets to close and pilot supply to fully pressurize. Reset air pressure can be applied by a remote 3/2 normally closed valve, or from an optional 3/2 normally closed solenoid, or a manual push button mounted on the reset adapter.

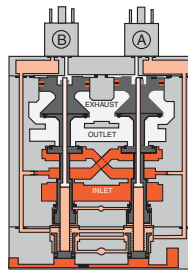

Status Indicator: The status indicator pressure switch will actuate when the main valve is operating normally, and will de-actuate when the main valve is in the locked-out position or inlet pressure is removed. This device is not part of the valve lockout function, but, rather, only reports the status of the main valve.

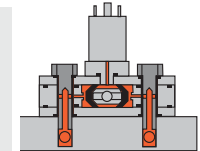

Status indicator in normal ready-to-run position.

Basic Size 12 and 30 valves require relatively large pilots to actuate and de-actuate the main valve elements. In order to achieve extremely quick valve response for such large pilots, a 2-stage solenoid pilot system is incorporated into the design. This keeps the required electrical current to operate the pilots to a minimum.

Basic Size 12 & 30 pilots

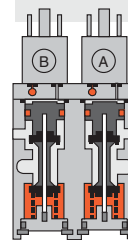

ACCESSORIES & OPTIONS

Electrical Connectors	Electrical Connector Form	Electrical Connector Type	Cord Length meters (feet)	Cord Diameter	Electrical Connector Model Number		
					Without Light	Lighted Connector	
						24 Volts DC	120 Volts AC
	EN 175301-803 Form A	Prewired Connector (18 gauge)	2 (6½)	6-mm	721K77	720K77-W	720K77-Z
	EN 175301-803 Form A	Prewired Connector (18 gauge)	2 (6½)	10-mm	371K77	383K77-W	383K77-Z
	EN 175301-803 Form A	Connector for threaded conduit (1/2 inch electrical conduit fittings)	–	–	723K77	724K77-W	724K77-Z
	EN 175301-803 Form A	Connector Only	–	–	937K87	936K87-W	936K87-Z

CAUTIONS: Do not use electrical connectors with surge suppressors, as this may increase valve response time when de-actuating the solenoids.

Downstream Pressure Monitoring

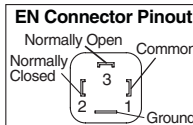

Redundant Downstream Feedback Switch

Model Number	Port Threads
RC26-13	3/8 NPT

- May be installed downstream on all double valves
- Provides a redundant means to verify the release of downstream pressure to next obstruction
- Factory preset, 5 psi (0.3 bar) - falling

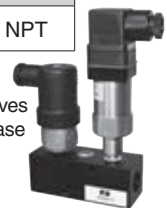

Pressure Switches

Connection Type	Model Number	Port Threads
EN 175301-803 Form A	586A86	1/8 NPT
M12	1153A30	1/8 NPT

*Pressure switch closes on falling pressure of 5 psig (0.34 bar).

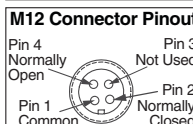

High-Flow, High Reduction Silencer Kits

Port Size	Kit Number*		Flow scfm	Dimensions inches (mm)			
	NPT threads	BSPT threads		A	B (NPT)	B (BSPT)	C
4	2324H77	2329H77	800 (378)	4.34 (110.2)	19.06 (484.1)	21.40 (543.6)	7.27 (184.7)
8	2325H77	2330H77	800 (378)	5.41 (137.4)	21.18 (538.0)	23.52 (597.4)	8.41 (213.6)
12	2326H77	2331H77	2080 (982)	6.74 (117.2)	25.85 (656.6)	28.20 (716.3)	10.66 (270.8)
30	2327H77	2332H77	7200 (3398)	9.85 (250.2)	41.55 (1055.4)	41.55 (1055.4)	13.47 (342.1)

* Kits include all plumbing required for installation. **Pressure Range:** 125 psig (8.6 bar) maximum.

Designed to improve equipment performance and reduce the Exponentially Perceived Noise (EPNdB) in the 35–40 dB range.

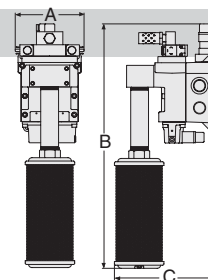

Control Reliable Double Valves with Dynamic Monitoring & Memory

DM^{2®} Series C Preassembled Wiring Kits

Preassembled Wiring Kits

These kits include 1 cable for the status indicator, and 3 cables with connector plus a cord grip for each.

Connector without Light	Kit Number*		Solenoid Connector Type	Length meters (feet)
	24 Volts DC	120 Volts AC		
2283H77	2532H77-W	2532H77-Z	EN 175301-803 Form A	5 (16.4)
2284H77	2533H77-W	2533H77-Z	EN 175301-803 Form A	10 (32.8)
2288H77**	-	-	M12	5 (16.4)
2289H77**	-	-	M12	10 (32.8)

* Each cable has one connector. **Coil includes light.

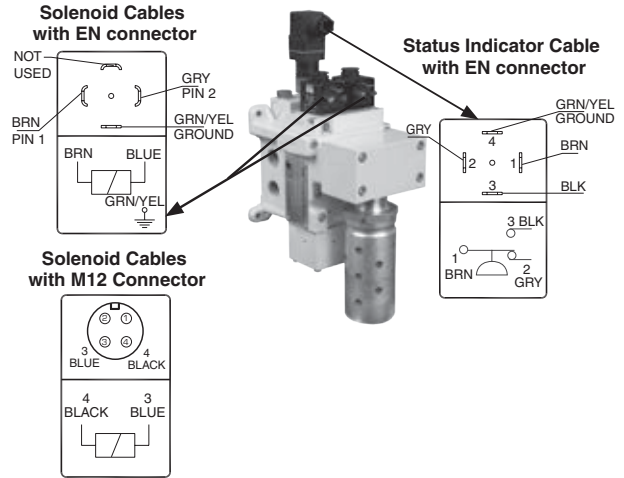

Wiring Kits with J-Box

Kit Number*	Connector Types	Length meters (feet)
2249H77	M12 - DIN	1 (3.3)
2250H77	M12 - M12	1 (3.3)

*24 volts DC only.

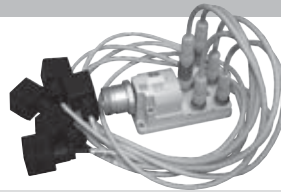

A J-Box is a junction box with a 10-pin MINI connector for connecting to the user's control system and (4) 5-pin M12 ports for connecting to the 3 solenoids and the status indicator on the DM^{2®} Series valve. The J-Box kits include the J-Box as described above and (4) 1-meter cables for connecting to the valve. These cables have a connector on each end. The status indicator cable and the (3) solenoid cables have an M12 connector on one end and an EN connector on the other end (M12-DIN).

Standard valves come with DIN type solenoid connections, but could be bought with M12 type connections as well. Therefore we also offer a kit that provides solenoid cables with an M12 connector on each end (M12-M12).

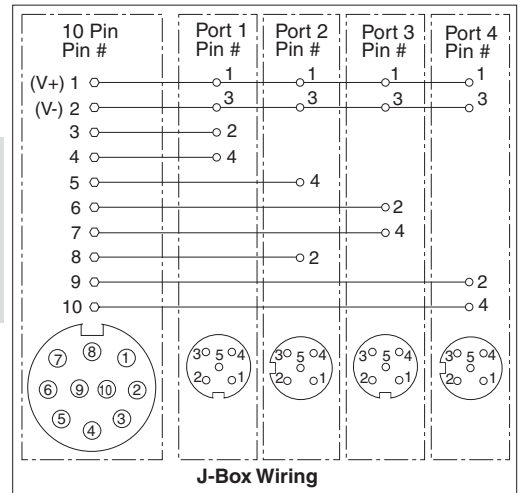
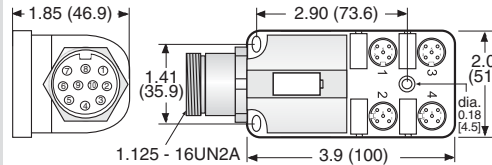

F3

10 PIN MINI Cable

Kit Number	Length meters (feet)
2253H77	3.66 (12)
2254H77	6.1 (20)
2255H77	9.1 (30)
2256H77	15.2 (50)

These cables have a 10-pin MINI connector for connecting the J-Box kits above to the user's control system. Kits include one cable with connector and cord grip. Cable conductors are 18-gauge wire.

- | | | | |
|-------|-----------------|-------|--------------------------|
| PIN # | | PIN # | |
| 1 | +24 volts DC | 6 | - |
| 2 | Common volts DC | 7 | Remote Reset |
| 3 | - | 8 | - |
| 4 | Solenoid A | 9 | Remote Valve Fault Light |
| 5 | Solenoid B | 10 | Remote System OK Light |

- Wire Colors:
- Orange
 - Blue
 - White w/Black
 - Red w/Black
 - Green w/Black
- Wire Colors:
- Orange w/Black
 - Red
 - Green/Yellow
 - Black
 - White



F

Outlet Port Pressure Monitoring Wiring Kit

Kit Number	Length meters (feet)
2251H77	1 (3.3)

Some customers prefer to monitor downstream pressure in addition to using the DM^{2®} or DM¹ Series valve. A convenient way to do this is to install a pressure switch in the extra outlet port that is provided on the valve. The Outlet Port Pressure Monitoring kit can be used with one of the J-Box kits above to split one of the M12 ports on the J-Box so that a pressure switch can be wired in as well. These kits consist of one port splitter (a Tee with three M12 connectors) and one M12-DIN cable (1 meter).

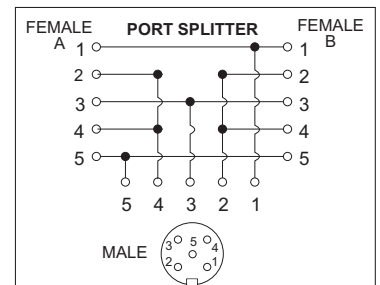
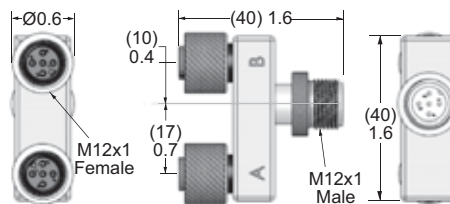

Pressure switch available separately, see valve options.

IMPORTANT NOTE: Please read carefully and thoroughly all of the **CAUTIONS, WARNINGS** on the inside back cover.



Online Version
Rev. 11/14/16

www.rosscontrols.com

F3.15

General Information

Standard Specifications

The standard specifications for the products on each page of this catalog are given on the same page or referenced. For solenoid pilot valves, models with internal pilot supply are listed. Most models are also available for use with external pilot supply or have a built-in pilot supply selector valve.

The products in this catalog are intended for use in industrial pneumatic systems. Most products are adaptable to other uses and conditions not covered by the standard specifications given in this catalog. Weights shown are approximate and are subject to change. Dimensions given, unless otherwise noted, are envelope dimensions (not for mounting). Consult ROSS for further information.

Port Threads

Ports of valves and bases described in this catalog have NPT (ANSI B2.1) threads. Other thread types can be specified by putting an appropriate prefix letter on the model or part number when ordering.

Thread Types by Model Prefix Letter

Pneumatic Port Threads	Prefix Letter	Threaded Electrical Opening
NPT (ANSI B2.1)	None	NPT
ISO 228 - DIN 259 Parallel, BSPP#	C*	—
ISO 228 - DIN 259 Parallel, BSPP#	D	G
ISO 228 - JIS B0203 Tapered#	J	ISO
SAE 1926- ISO 11926	S	NPT

* Used only for filters, regulators, lubricators.

ISO 228 threads supersedes BSPP, G and JIS thread types.

Flow Ratings

Flow ratings are expressed as C_v where $C_v = 1$ corresponds to a steady state air flow of approximately 32 scfm under the following conditions:

Inlet pressure = 100 psig (6.7 bar)
Pressure drop = 10 psi (0.69 bar)
Air temperature = 68°F (20°C)
Relative humidity = 36%

Note: Because widely differing test standards are used to measure C_v values, the figures given in this catalog should not be used to compare ROSS valves with those of other makers. The C_v ratings given here are intended only for use with performance charts published by ROSS. The C_v ratings are averages for the various flow paths through the valve and are for steady flow conditions.

Approvals and Certifications

ROSS products are designed to meet a number of industrial standards, including the Canadian Standards Association (C.S.A.) guidelines. For more information on specific product approvals, contact your local distributor or ROSS.

Solenoids

All ROSS standard solenoids are rated for continuous duty (unless noted otherwise) and will operate the valve within the air pressure range specified in this catalog.

Explosion-Proof Solenoid Pilot available, for more information consult ROSS.

Voltage & Hertz

When ordering a solenoid valve, also specify the desired solenoid voltage and hertz.

Voltage Types by Model Suffix Letter

Voltage	Suffix Letter
120 volts AC	Z
220 volts AC	Y
12 volts DC	H
24 volts DC	W
48 volts DC	M
90 volts DC	K
110 volts DC	P
125 volts DC	C

Recommended Solenoid Voltages: 100-110 volts AC, 50 Hz; 100-120 volts AC, 60 Hz; 24 volts DC; 110 volts DC.

In addition, the following voltages are available:

200, 220 volts AC, 50 Hz
200, 240, 480 volts AC, 60 Hz
24, 48, 220 volts AC, 50 Hz
240 volts AC, 60 Hz
200, 220 volts AC, 50 Hz
200, 240 volts AC, 60 Hz.

For example: Model 2773B5001, 120 volts AC, 60 Hz.
Model W6076B2401, 220 volts AC, 50 Hz.

Please note that not all configurations are available for all models.

For additional information or help with voltage configuration, please contact your local distributor or ROSS.

Port Identification

Valve symbols in this catalog conform to the ISO 1219-1:1991 standard of the International Organization for Standardization (ISO) and the SAE J2051 standard of the Society of Automotive Engineers (SAE) respectively.

Information or Technical Assistance

For additional information or application assistance concerning ROSS products, consult ROSS or your local ROSS distributor (see contact information on the back cover).

Order Placement

For order placement, consult ROSS or your local ROSS distributor.

For a current list of countries and local distributors, visit ROSS' website at www.rosscontrols.com.

CAUTIONS, WARNINGS and STANDARD WARRANTY

PRE-INSTALLATION or SERVICE

1. Before servicing a valve or other pneumatic component, be sure that all sources of energy are turned off, the entire pneumatic system is shut off and exhausted, and all power sources are locked out (ref: OSHA 1910.147, EN 1037).
2. All ROSS products, including service kits and parts, should be installed and/or serviced only by persons having training and experience with pneumatic equipment. Because any installation can be tampered with or need servicing after installation, persons responsible for the safety of others or the care of equipment must check every installation on a regular basis and perform all necessary maintenance.
3. All applicable instructions should be read and complied with before using any fluid power system in order to prevent harm to persons or equipment. In addition, overhauled or serviced valves must be functionally tested prior to installation and use. If you have any questions, call your nearest ROSS location listed on the cover of this document.
4. Each ROSS product should be used within its specification limits. In addition, use only ROSS parts to repair ROSS products.

WARNING: Failure to follow these directions can adversely affect the performance of the product or result in the potential for human injury or damage to property.

FILTRATION and LUBRICATION

5. Dirt, scale, moisture, etc. are present in virtually every air system. Although some valves are more tolerant of these contaminants than others, best performance will be realized if a filter is installed to clean the air supply, thus preventing contaminants from interfering with the proper performance of the equipment. ROSS recommends a filter with a 5-micron rating for normal applications.
6. All standard ROSS filters and lubricators with polycarbonate plastic bowls are designed for compressed air applications only. Do *not* fail to use the metal bowl guard, where provided, to minimize danger from high pressure fragmentation in the event of bowl failure. Do not expose these products to certain fluids, such as alcohol or liquefied petroleum gas, as they can cause bowls to rupture, creating a combustible condition, hazardous leakage, and the potential for human injury or damage to property. Immediately replace a crazed, cracked, or deteriorated bowl. When bowl gets dirty, replace it or wipe it with a clean dry cloth.

7. Only use lubricants which are compatible with materials used in the valves and other components in the system. Normally, compatible lubricants are petroleum based oils with oxidation inhibitors, an aniline point between 180°F (82°C) and 220°F (104°C), and an ISO 32, or lighter, viscosity. Avoid oils with phosphate type additives which can harm polyurethane components, potentially leading to valve failure which risks human injury, and/or damage to property.

AVOID INTAKE/EXHAUST RESTRICTION

8. Do not restrict the air flow in the supply line. To do so could reduce the pressure of the supply air below the minimum requirements for the valve and thereby cause erratic action.
9. Do not restrict a valve's exhaust port as this can adversely affect its operation. Exhaust silencers must be resistant to clogging and must have flow capacities at least as great as the exhaust capacities of the valves. Contamination of the silencer can result in reduced flow and increased back pressure.

WARNING: ROSS expressly disclaims all warranties and responsibility for any unsatisfactory performance or injuries caused by the use of the wrong type, wrong size, or an inadequately maintained silencer installed with a ROSS product.

POWER PRESSES

10. Mechanical power presses and other potentially hazardous machinery using a pneumatically controlled clutch and brake mechanism must use a press control double valve with a monitoring device. A double valve without a self-contained monitoring device should be used only in conjunction with a control system which assures monitoring of the valve. All double valve installations involving hazardous applications should incorporate a monitoring system which inhibits further operation of the valve and machine in the event of a failure within the valve mechanism.

ENERGY ISOLATION/EMERGENCY STOP

11. Per specifications and regulations, ROSS L-O-X® and L-O-X® with EEZ-ON® operation products are defined as energy isolation devices, NOT AS EMERGENCY STOP DEVICES.

STANDARD WARRANTY

limited to repair or replacement of the product or refund of the purchase price paid solely at the discretion of ROSS and provided such product is returned to ROSS freight prepaid and upon examination by ROSS is found to be defective. This warranty becomes void in the event that product has been subject to misuse, misapplication, improper maintenance, modification or tampering.

THE WARRANTY EXPRESSED ABOVE IS IN LIEU OF AND EXCLUSIVE OF ALL OTHER WARRANTIES AND ROSS EXPRESSLY DISCLAIMS ALL OTHER WARRANTIES EITHER EXPRESSED OR IMPLIED WITH RESPECT TO MERCHANTABILITY OR FITNESS FOR A PARTICULAR PURPOSE. ROSS MAKES NO WARRANTY WITH RESPECT TO ITS PRODUCTS MEETING THE PROVISIONS OF ANY GOVERNMENTAL OCCUPATIONAL SAFETY AND/OR HEALTH LAWS OR REGULATIONS. IN NO EVENT IS ROSS LIABLE TO PURCHASER, USER, THEIR EMPLOYEES OR OTHERS FOR INCIDENTAL OR CONSEQUENTIAL DAMAGES WHICH MAY RESULT FROM A BREACH OF THE WARRANTY DESCRIBED ABOVE OR THE USE OR MISUSE OF THE PRODUCTS. NO STATEMENT OF ANY REPRESENTATIVE OR EMPLOYEE OF ROSS MAY EXTEND THE LIABILITY OF ROSS AS SET FORTH HEREIN.

All products sold by ROSS CONTROLS are warranted for a one-year period [with the exception of all Filters, Regulators and Lubricators ("FRLs") which are warranted for a period of seven years] from the date of purchase to be free of defects in material and workmanship. ROSS' obligation under this warranty is

