

Bulletin

E425H

Extension

Filters-Regulators- Lubricators in Modular Design

Series MD3™ & MD4™

Optimized Air Preparation

- **High Flow**
- **acc. to ISO-Standard**



Please
see also:
FRL
Bulletin
E425H

ROSS

FRL - Line Extension Series MD3™

- G 1/4 to G 1/2
- Flow-rating up to 3100 l/min
- Modern, aesthetically pleasing design
- Modular design
- Rugged construction

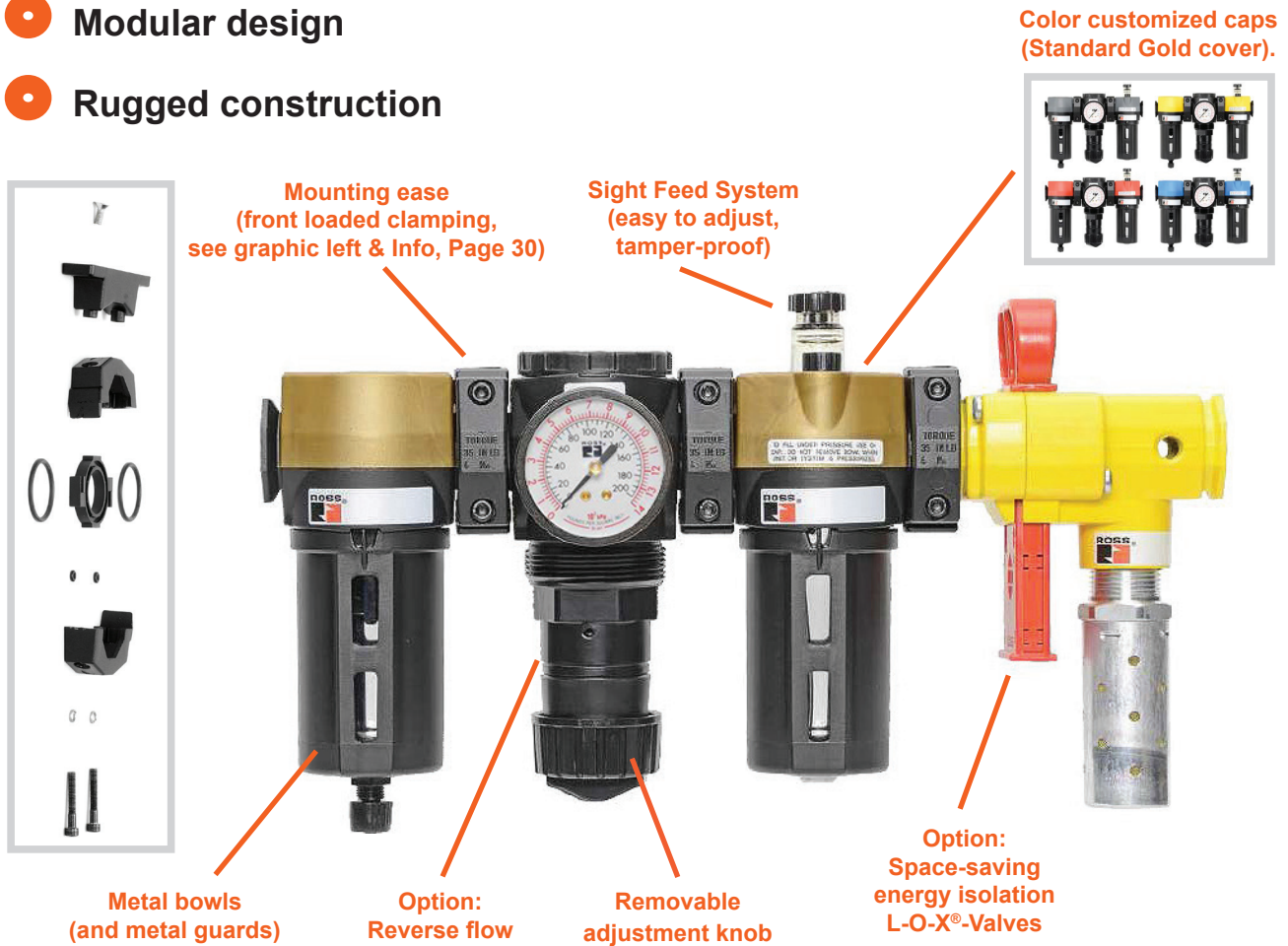

Designed and tested to ISO 5782-2, ISO 6301-2 and ISO 6953-1 Standards.

OVERVIEW

FILTERS.....	Page 3 – 5
"CLEAN AIR" PACKAGE	Page 6 – 7
REGULATORS	Page 8 – 9
LUBRICATORS.....	Page 10
COMBINATIONS.....	Page 13 – 14
ACCESSORIES	Page 30 – 32

Spare Part Information

Consult
ROSS EUROPA®
or your nearest
ROSS® Service Point
for Details.

G 1/4, G 3/8 & G 1/2 – Flow to 2600 l/min

HOW TO ORDER

(Choose your options in **RED** to configure your model number)

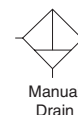

MD3 **50P** **A** **M** **C** **B** **2** **A**

BOWL TYPE	
Polycarbonate (151 ml)	50P
Metal (177 ml)	50M

FILTER ELEMENT TYPE	
40 µm Sintered bronze	A
5 µm Polyethylene	B
5 µm Sintered bronze	E
20 µm Sintered bronze	F

BOWL DRAIN	
Manual	M
Float	F
Less Drain Fitting (1/4 NPT female instead)	L

PORT SIZE	
G 1/4	B
G 3/8	C
G 1/2	D
1/4 NPT	2
3/8 NPT	3
1/2 NPT	4

DIFFERENTIAL PRESSURE GAUGE	
No Gauge (without gauge port)	A
Small Slide Gauge	S

CAP COLOR	
Gold	2
Gray	G
Yellow	Y
Red	R
Blue	B

Port Size	Bowl Type	Dimensions mm				Weight kg
		A	B*	C	Depth	
G 1/4	Polycarbonate	76,2	140,6	28,3	63,8	0,59
G 3/8	Aluminum	127	163,1	28,3	70,1	0,64
G 1/2						

* With small differential gauge, add 31 mm to Dimension C.
Bowl removal clearance: 79 mm.

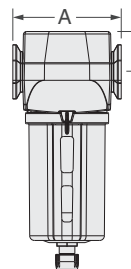

REPLACEMENT FILTER ELEMENTS*		
Element Rating	Material	Part Number
5 µm	Polyethylene	R-A60F-03PE5
5 µm	Sintered bronze	R-A60F-03E5
20 µm	Sintered bronze	R-A60F-03E4
40 µm	Sintered bronze	R-A60F-03E3

* For polycarbonate and metal bowl types.

FLOW CHARTS

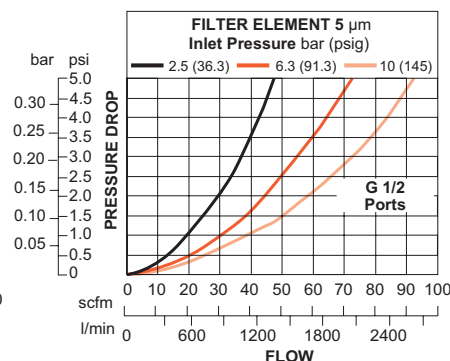
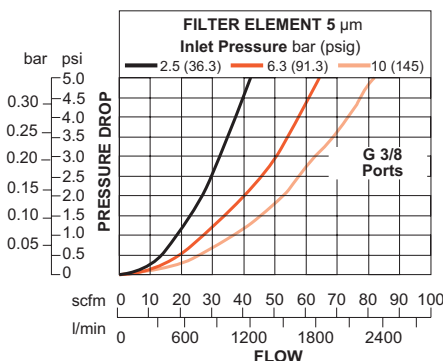
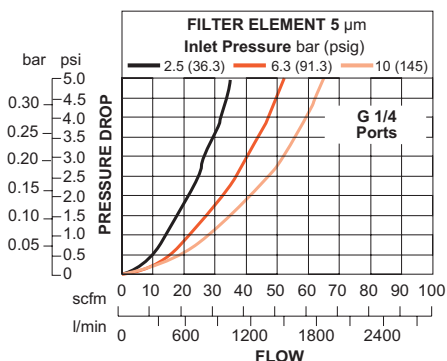

Options: Differential Pressure Gauge, for additional information, see Page 32.

Options: External Bowl Drains, for additional information, see Page 32.

Accessories ordered separately, see Pages 30 - 32.

STANDARD SPECIFICATIONS (for all products on this page)

Construction: Sintered or fiber.

Ambient/Media Temperature:

Polycarbonate bowl: 4° to 52°C.

Metal bowl: 4° to 80°C.

Flow Medium: Compressed air.

Inlet Pressure - Automatic drain model:

Polycarbonate bowl: 2 to 10 bar.

Metal bowl: 2 to 14 bar.

Inlet Pressure - Manual drain model:

Polycarbonate bowl: 0 to 10 bar.

Metal bowl: 0 to 17 bar.

Filter Element, Polyethylene: 5-micron;

Filter Element, Sintered bronze: 5-, 20-, or 40-micron.

Body: Die-cast-zinc.

Bowl: Polycarbonate bowl with nylon shatterguard, or aluminum bowl with clear nylon sight glass.

Seals: Nitrile.

IMPORTANT NOTE: Please read carefully and thoroughly all of the **CAUTIONS, WARNINGS** on Pages 33 and 34

G 1/4, G 3/8 & G 1/2 – Flow to 3500 l/min



HOW TO ORDER

(Choose your options in **RED** to configure your model number)

MD3 **50P** **C** **M** **C** **B** **2** **A**

BOWL TYPE	
Polycarbonate (151 ml)	50P
Metal (177 ml)	50M
Extended Metal Bowl (295 ml)	50E

FILTER ELEMENT TYPE	
0,3 µm Borosilicate glass	C
0,01 µm Borosilicate glass	D

BOWL DRAIN	
Manual	M
Float	F
Less Drain Fitting (1/4 NPT female instead)	L

PORT SIZE	
G 1/4	B
G 3/8	C
G 1/2	D
1/4 NPT	2
3/8 NPT	3
1/2 NPT	4

DIFFERENTIAL PRESSURE GAUGE	
No Gauge (without gauge port)	A
Small Slide Gauge	S

CAP COLOR	
Gold	2
Gray	G
Yellow	Y
Red	R
Blue	B

Port Size	Bowl Type	Dimensions mm				Weight kg
		A	B*	C	Depth	
G 1/4	Polycarbonate	76,2	140,6	59,3	63,8	0,59
G 3/8	Aluminum	76,2	163,1	59,3	70,1	0,64
G 1/2	Extended Aluminum	76,2	241,6	59,3	70,1	0,70

*Bowl removal clearance: add 79 mm. Extended bowl removal clearance: 155 mm.

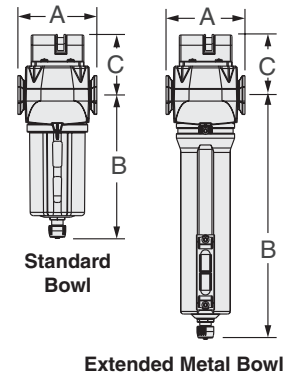

REPLACEMENT FILTER ELEMENTS					
Elem. Rating	Bowl Type	Part Number	Elem. Rating	Bowl Type	Part Number
0,3 µm	Polycarbonate	R-A60F-23	0,01 µm	Polycarbonate	R-A60F-23E8
	Metal	R-A60F-29		Metal	R-A60F-29E8
	Extended Metal	R-A60F-32		Extended Metal	R-A60F-32E8

FLOW CHARTS

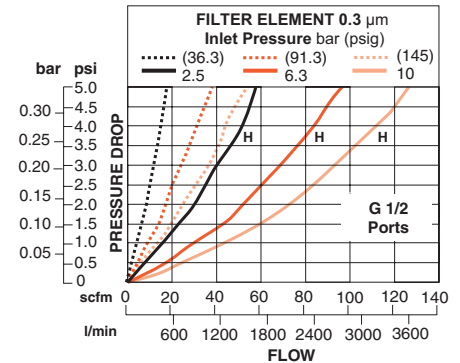
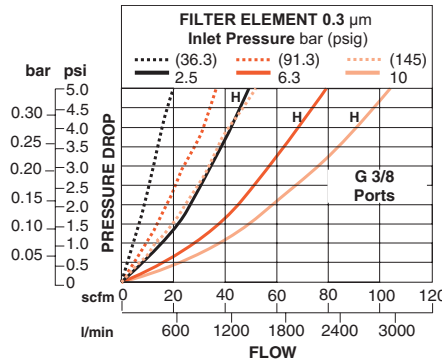
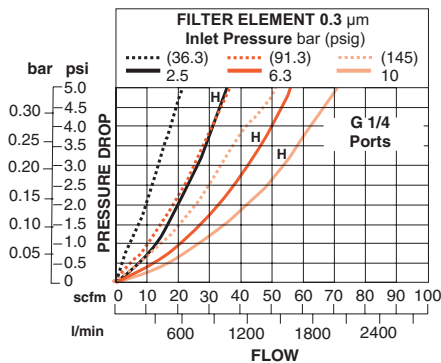

H designates models with extended bowls.

Options: External Bowl Drains, for additional information, see Page 32.
Accessories ordered separately, see Page 30 - 32.

STANDARD SPECIFICATIONS (for all products on this page)

Construction: Fiber.

Ambient/Media Temperature:

Polycarbonate bowl: 4° to 52°C.

Metal bowl: 4° to 80°C.

Flow Medium: Compressed air.

Inlet Pressure, Automatic drain model:

Polycarbonate bowl: 2 to 10 bar.

Metal bowl: 2 to 14 bar.

Inlet Pressure, Manual drain model:

Polycarbonate bowl: 0 to 10 bar.

Metal bowl: 0 to 17 bar.

Filter Element: Borosilicate-glass-fiber coalescing element;

0,3 Micron (standard) or 0,01 Micron (optional).

Body: Die-cast zinc.

Seals: Nitrile.

Bowl: Polycarbonate bowl with nylon shatterguard, or aluminum bowl with clear nylon sight glass.

IMPORTANT NOTE: Please read carefully and thoroughly all of the **CAUTIONS, WARNINGS** on Pages 33 and 34

G 1/4, G 3/8 & G 1/2 – Flow to 3500 l/min

HOW TO ORDER

(Choose your options in **RED** to configure your model number)

MD3 **50P** **C** **B** **2**

BOWL SIZE	
Polycarbonate (151 ml)	50P
Metal (177 ml)	50M
Extended Metal Bowl (295 ml)	50E

PORT SIZE	
G 1/4	B
G 3/8	C
G 1/2	D
1/4 NPT	2
3/8 NPT	3
1/2 NPT	4

CAP COLOR	
Gold	2
Gray	G
Yellow	Y
Red	R
Blue	B

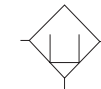

Manual Drain



Port Size	Bowl Type	Dimensions mm				Weight kg
		A	B*	C	Depth	
G 1/4	Polycarbonate	76,2	140,6	28,3	63,8	0,59
G 3/8	Aluminum	76,2	163,1	28,3	70,1	0,64
G 1/2	Extended Aluminum	76,2	241,6	28,3	70,1	0,70

*Bowl removal clearance: add 79 mm.
Extended Bowl removal clearance: add 155 mm.

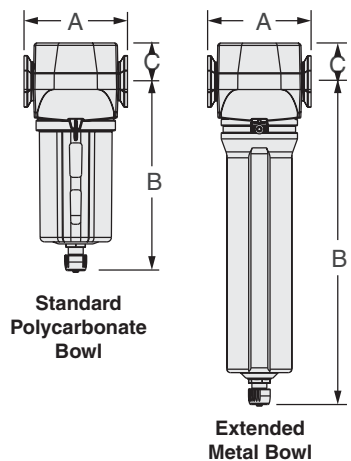

REPLACEMENT FILTER ELEMENTS	
Bowl Type	Part Number
Polycarbonate	R-A60F-29E9
Metal	R-A60F-29E9
Extended Metal	R-A60F-32E9

FLOW CHARTS

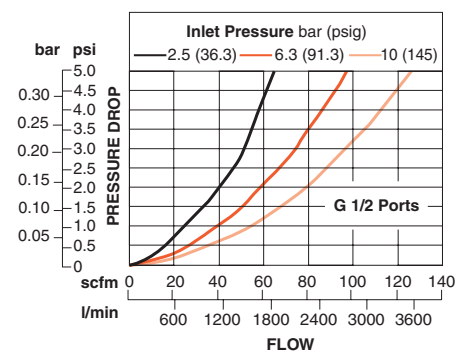
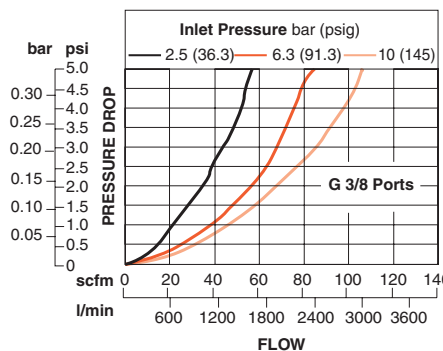
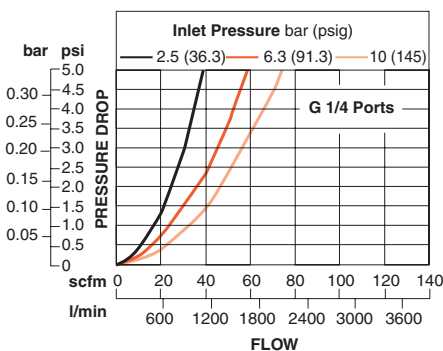

Accessories ordered separately, see Pages 30 - 32.

STANDARD SPECIFICATIONS (for all products on this page)

Construction: Fiber.

Ambient/Media Temperature:

With polycarbonate bowl: 4° to 52°C.

With metal bowl: 4° to 80°C.

Flow Medium: Compressed air.

Inlet Pressure:

With polycarbonate bowl: 0 to 10 bar.

With metal bowl: 0 to 17 bar.

Filter Element: Activated carbon with urethane seals.

Bowl Drain: Manual drain.

Body: Die-cast zinc.

Bowl: Polycarbonate with nylon shatterguard, aluminum bowl with clear nylon sight glass, or extended aluminum bowl with clear nylon sight glass.

Seals: Nitrile.

IMPORTANT NOTE: Please read carefully and thoroughly all of the **CAUTIONS, WARNINGS** on Pages 33 and 34

G 1/4, G 3/8 & G 1/2 – Flow to 3500 l/min

HOW TO ORDER

(Choose your options in **RED** to configure your model number)

MD3	CAP	1	A	C	1	B	2	A	1
------------	------------	----------	----------	----------	----------	----------	----------	----------	----------

BOWL SIZE	
Polycarbonate (151 ml)	1
Metal (177 ml)	2
Extended Metal Bowl (295 ml)	3

COALESCING ELEMENT	
0,3 µm Borosilicate glass	A
0,01 µm Borosilicate glass	B

BOWL DRAIN	
Manual	1
Float Drain	F

PORT SIZE	
G 1/4	B
G 3/8	C
G 1/2	D
1/4 NPT	2
3/8 NPT	3
1/2 NPT	4

CAP COLOR	
Gold	2
Gray	G
Yellow	Y
Red	R
Blue	B

Option: L-O-X® or EEZ-ON®	
L-O-X® on Outlet Side	1
L-O-X® on Inlet Side	2
EEZ-ON® on Outlet Side	3
EEZ-ON® on Inlet Side	4
No L-O-X®	

DIFFERENT. PRESSURE GAUGE	
No Gauge (without gauge port)	A
Small Slide Gauge	S

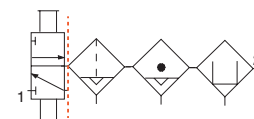

"Clean Air" Package with L-O-X®

REPLACEMENT COALESCING ELEMENTS		
Element Rating	Bowl Type	Part Number
0,3 µm	Polycarbonate	R-A60F-23
	Metal	R-A60F-29
	Extended Metal	R-A60F-32
0,01 µm	Polycarbonate	R-A60F-23E8
	Metal	R-A60F-29E8
	Extended Metal	R-A60F-32E8

REPLACEM. ADSORBING ELEMENTS	
Bowl Type	Part Number
Polycarbonate	R-A60F-29E9
Metal	R-A60F-29E9
Extended Metal	R-A60F-29

REPLACEMENT FILTER ELEMENTS		
Element Rating	Material	Part Number
5 µm	Polyethylene	R-A60F-03PE5

Accessories, see Pages 30 - 32.

STANDARD SPECIFICATIONS (for all products on this page)

Construction: Filter, Coalescing Filter - Fiber.

Ambient/Media Temperature:

With polycarbonate bowl: 4° to 52°C.

With metal bowl: 4° to 80°C.

With metal bowl & float drain: 4° to 80°C.

Inlet Pressure, Automatic drain model:

With polycarbonate bowl: 2 to 10 bar.

With metal bowl: 2 to 14 bar.

Inlet Pressure, Manual drain model:

With polycarbonate bowl: 0 to 10 bar.

With metal bowl: 0 to 17 bar.

Filter Element: 5 µm rated Polyethylene.

Coalescing Filter Element: 0,3 Micron or 0,01 Micron rated borosilicate-glass-fiber.

Adsorbing Filter Element: Activated carbon with urethane seals.

Bowl Drain:

Filter & coalescing filter: Internal float drain or manual drain.

Adsorber filter: Manual drain only.

Body: Die-cast zinc.

Bowl: Polycarbonate bowl with nylon shatterguard; aluminum bowl with clear nylon sight glass; extended aluminum bowl with clear nylon sight glass and higher flow filter element (for coalescing and adsorber filter only).

Seals: Nitrile.

IMPORTANT NOTE: Please read carefully and thoroughly all of the **CAUTIONS, WARNINGS** on Pages 33 and 34

Port Size	Bowl Type	Dimensions mm				Weight kg
		A*	B**	C	Depth	
G 1/4	Polycarbonate	243,3	140,6	59,3	63,8	2,0
G 3/8	Aluminum	243,3	163,1	59,3	70,1	2,1
G 1/2	Extended Aluminum	243,3	241,6	59,3	70,1	2,2

* L-O-X® Valve: With the lockout valve, add 102 mm to Dimension A.
 ** Bowl removal clearance: add 79 mm. Extended bowl removal clearance: add 155 mm.

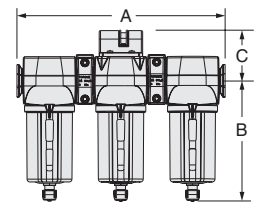

Standard Polycarbonate Bowls

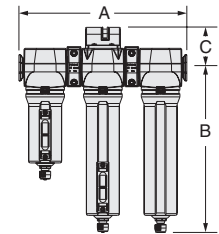

Extended Metal Bowls

FLOW CHARTS

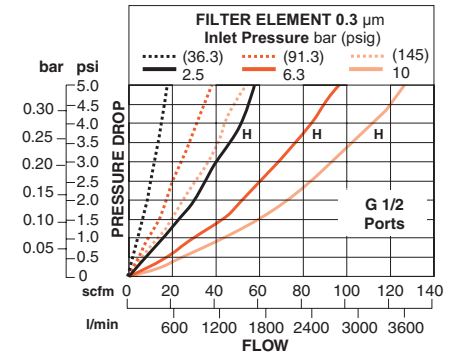
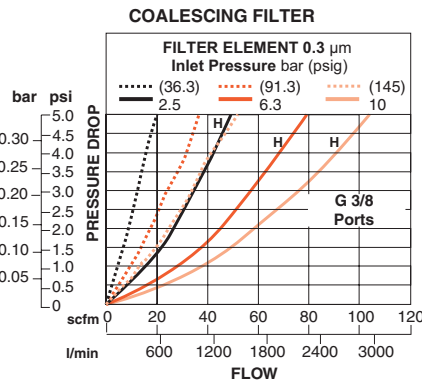
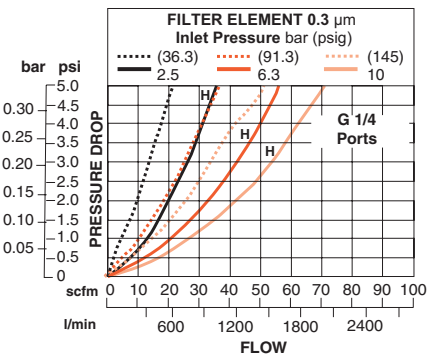
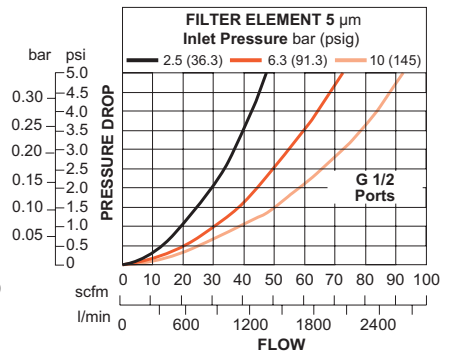
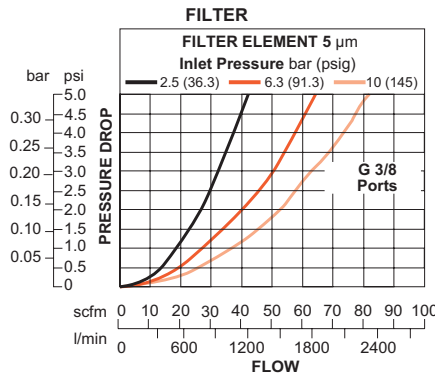
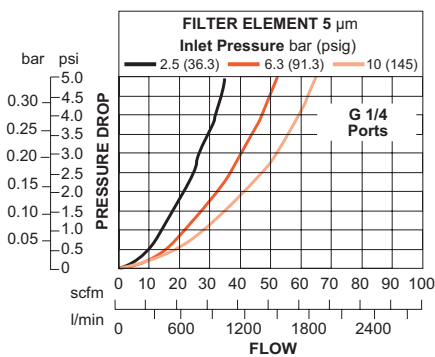

H designates models with extended bowls.

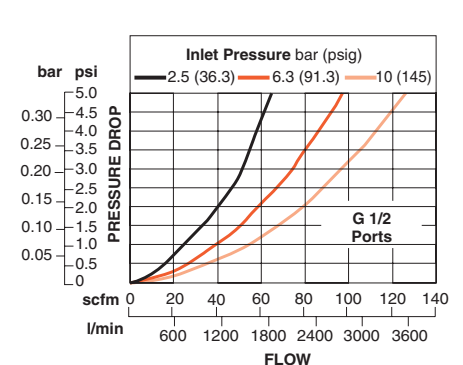
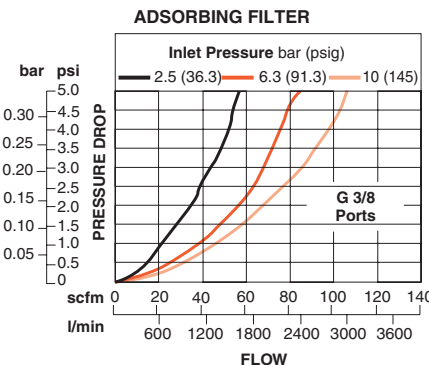
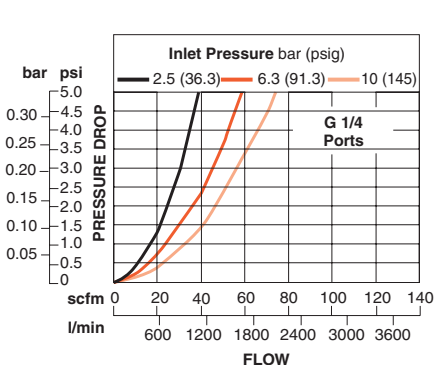

IMPORTANT NOTE: Please read carefully and thoroughly all of the **CAUTIONS, WARNINGS** on Pages 33 and 34



G 1/4, G 3/8 & G 1/2 – Flow to 3400 l/min

HOW TO ORDER

(Choose your options in **RED** to configure your model number)

MD3 **52K** **A** **R** **C** **B** **2** **A**

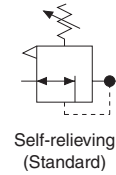

ADJUSTMENT TYPE	
Knob	52K
Tee Handle	52T
Locking Knob	52L

ADJUSTMENT RANGE	
0 - 13,8 bar	A
0 - 10,3 bar	B
0 - 6,9 bar	C
0 - 3,4 bar	D

FLOW OPTIONS	
Reverse Flow	R
Standard Flow	S

PORT SIZE	
G 1/4	B
G 3/8	C
G 1/2	D
1/4 NPT	2
3/8 NPT	3
1/2 NPT	4

GAUGE	
No Gauge	A
Gauge (0 - 14 bar)	B
Gauge (0 - 4 bar)	C
No Gauge, with Panel Mount Nut	D
With Panel Mount Nut & Gauge (0 - 14 bar)	E
With Panel Mount Nut & Gauge (0 - 4 bar)	F

Port Size	Dimensions mm				Weight+ kg
	A	B*	C**	Depth+	
G 1/4 to G 3/4	76,2	114,9	37	63,8	0,86

* Dome removal clearance: add 14,6 mm.
**Cap removal clearance: add 19,1 mm.
+ Less gauge.

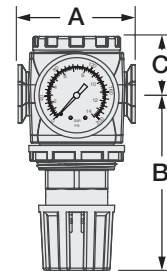

FLOW CHARTS

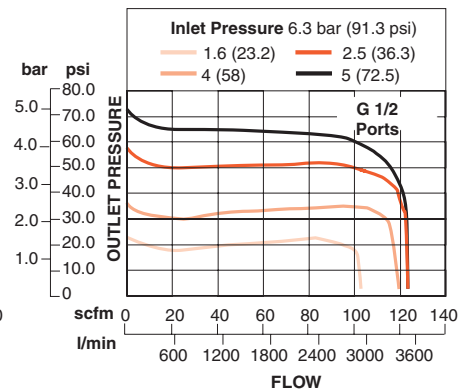
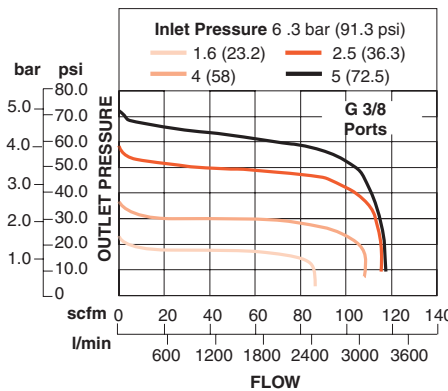
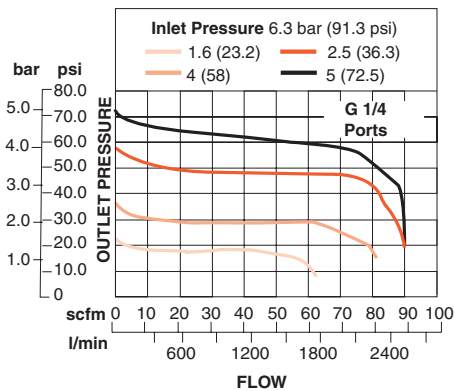

Accessories ordered separately, see Pages 30 - 32.

STANDARD SPECIFICATIONS (for all products on this page)

Construction: Diaphragm.
Self-relieving, for non-relieving option consult ROSS.
Ambient/Media Temperature: 4° to 80°C.
Flow Medium: Compressed Air.
Inlet Pressure: 21 bar maximum.
Outlet Pressure: Adjustable up to 14 bar.
Optional Pressure Adjustment Locking Key: Removable.
Pressure Gauge: 0 - 14 bar or 0 - 4 bar;
G 1/4 (or 1/4" NPT) gauge ports, front and rear.

Panel Mounting: 52 mm hole required.
Self-relieving: Non-relieving optional.
Body: Zinc.
Dome: Nylon.
Knob: Acetal.
Seals: Nitrile.
Valve: Brass.
Valve Cap: Nylon.

IMPORTANT NOTE: Please read carefully and thoroughly all of the **CAUTIONS, WARNINGS** on Pages 33 and 34

G 1/4, G 3/8 & G 1/2 – Flow to 3100 l/min

HOW TO ORDER

(Choose your options in **RED** to configure your model number)

MD3 **53P** **B** **M** **C** **B** **A** **A** **1**

BOWL SIZE	
Polycarbon. (151 ml)	53P
Metal (177 ml)	53M

FILTER ELEMENT TYPE	
40 µm Sintered bronze	A
5 µm Polyethylene	B
5 µm Sintered bronze	E
20 µm Sintered bronze	F

BOWL DRAIN	
Manual	M
Float Drain	F
Less Drain Fitting (1/4 NPT female instead)	L

PORT SIZE	
G 1/4	B
G 3/8	C
G 1/2	D
1/4 NPT	2
3/8 NPT	3
1/2 NPT	4

ADJUSTMENT RANGE	
0 - 13,8 bar	A
0 - 10 bar	B
0 - 6,9 bar	C
0 - 3,4 bar	D
Reverse Flow 0 - 13,8 bar	F
Reverse Flow 0 - 10,3 bar	G
Reverse Flow 0 - 6,9 bar	H
Reverse Flow 0 - 3,4 bar	J

L-O-X® VALVE (optional)	
L-O-X® on Outlet Side	1
L-O-X® on the Inlet Side (must also choose Reverse Flow)	2
EEZ-ON® on Outlet Side	3
EEZ-ON® on Inlet Side (must also choose Reverse Flow)	4
Blank - No L-O-X®	

GAUGE	
No Gauge	A
Gauge 0 - 14 bar	B
Gauge 0 - 4 bar	C
No gauge, with Panel Mount Nut	D
With Panel Mount Nut & Gauge 0 - 14 bar	E
With Panel Mount Nut & Gauge 0 - 4 bar	F

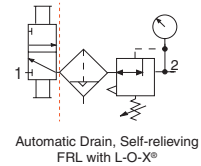

Bowl Type	Dimensions mm				Weight kg
	A	B*	C	Depth	
Polycarbonate	76,2	140,6	119	63,8	0,90
Metal	76,2	163,1	119	70,1	0,99

L-O-X® Valve: With the lockout valve, add 102 mm to Dimension A.

* Bowl removal clearance: add 79 mm.

Dimensions above reflect less gauge.



REPLACEMENT FILTER ELEMENTS*		
Elem. Rating	Material	Part Number
5 µm	Polyethylene	R-A60F-03PE5
5 µm	Sintered Bronze	R-A60F-03E5
20 µm	Sintered Bronze	R-A60F-03E4
40 µm	Sintered Bronze	R-A60F-03E3

* For Polycarbonate and metal bowl types.

FLOW CHARTS

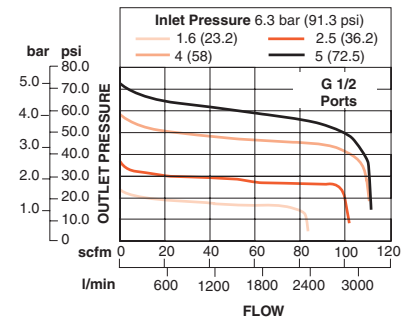
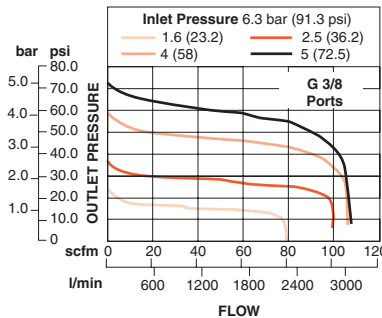
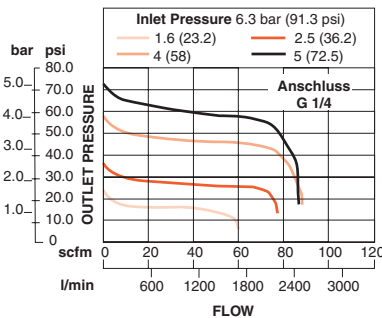

Options: External Bowl Drains, see Page 32. Accessories ordered separately, see Pages 30 - 32.

STANDARD SPECIFICATIONS (for all products on this page)

Construction: Regulator, diaphragm.

Ambient/Media Temperature:

Polycarbonate bowl: 4° to 52°C.

Metal bowl: 4° to 80°C.

Flow Medium: Compressed air.

Inlet Pressure, Automatic drain model:

Polycarbonate bowl: 2 to 10 bar.

Metal bowl: 2 to 14 bar.

Inlet Pressure, Manual drain model:

Polycarbonate bowl: 0 to 10 bar.

Metal bowl: 0 to 17 bar.

Outlet Pressure: Adjustable up to 14 bar.

Pressure Adjustment Locking Key: Removable.

Pressure Gauge: 0 - 14 bar or 0 - 4 bar;
G 1/4 (or 1/4" NPT) gauge ports, front and rear.

Panel Mounting: 52 mm hole required.

Body: Zinc.

Dome: Nylon.

Bowl: Polycarbonate with nylon shatterguard, or aluminum bowl with clear nylon sight glass.

Seals: Nitrile.

Valve: Brass.

IMPORTANT NOTE: Please read carefully and thoroughly all of the **CAUTIONS, WARNINGS** on Pages 33 and 34

G 1/4, G 3/8 & G 1/2 – Flow to 4200 l/min

HOW TO ORDER

(Choose your options in **RED** to configure your model number)

MD3 **51P** **Q** **C** **B** **2**

BOWL SIZE	
Polycarbonate (151 ml)	51P
Metal (177 ml)	51M
Extended Metal Bowl (295 ml)	51E

LUBRICATOR FILL TYPE	
Quick Fill Cap	Q
Fill Port	S

PORT SIZE	
G 1/4	B
G 3/8	C
G 1/2	D
1/4 NPT	2
3/8 NPT	3
1/2 NPT	4

CAP COLOR	
Gold	2
Gray	G
Yellow	Y
Red	R
Blue	B



Bowl Type	Dimensions mm				Weight kg
	A	B**	C	Depth	
Polycarbonate	76,2	119,9	56,1	63,8	0,59
Aluminium	76,2	152,9	56,1	70,1	0,64
Extended Aluminium	76,2	238	56,1	70,1	0,70

** Bowl removal clearance: add 79 mm.
Extended Bowl removal clearance: add 155 mm.

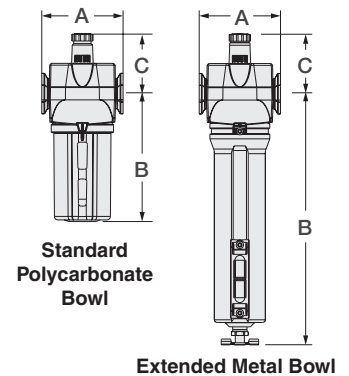

FLOW CHARTS

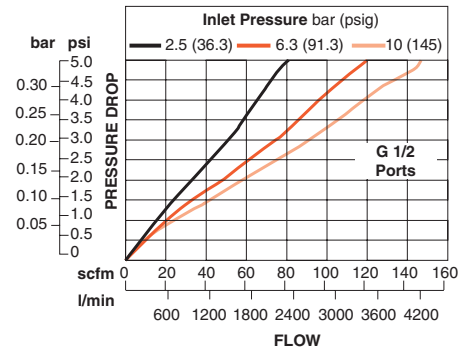
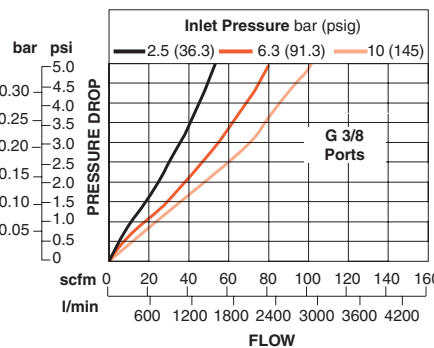
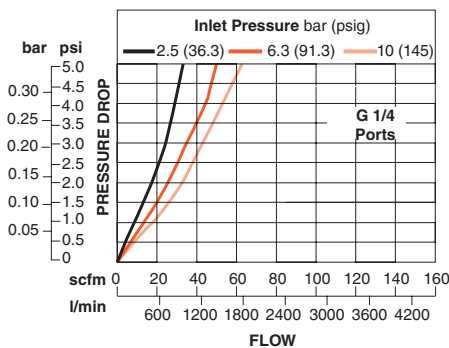

Accessories ordered separately, see Pages 30 - 32.

STANDARD SPECIFICATIONS (for all products on this page)

Construction: Sight-Feed.

Ambient/Media Temperature:

Polycarbonate bowl: 4° to 52°C.

Metal bowl: 4° to 80°C.

Flow Medium: Compressed air.

Inlet Pressure:

Polycarbonate bowl: 10 bar maximum.

Metal bowl: 17 bar maximum.

Oil Adjustment: External; tamper resistant.

Body: Zinc.

Bowl: Polycarbonate with nylon shatterguard, or aluminum bowl with clear nylon sight glass.

Sight-Feed Dome: Nylon.

Seals: Nitrile.

IMPORTANT NOTE: Please read carefully and thoroughly all of the **CAUTIONS, WARNINGS** on Pages 33 and 34

Integrated Filter/Regulator & Lubricator Combinations

Series MD3™

G 1/4, G 3/8 & G 1/2 – Flow to 3100 l/min

HOW TO ORDER

(Choose your options in **RED** to configure your model number)

MD3	53P	B	B	2	C	B	2	Q	1
BOWL SIZE		FILTER ELEMENT		BOWL DRAIN		LUBRICATOR FILL		L-O-X® VALVE (optional)	
Polycarbonate (151 ml) 53P		40 µm Sintered bronze A		Manual 2		Quick Fill Cap Q		L-O-X® on Outlet Side 1	
Metal (177 ml) 53M		5 µm Polyethylene B		Float Drain 0		Fill Port S		L-O-X® on Inlet Side (must also choose reverse flow) 2	
Metal (177 ml) - on Filter 53E		5 µm Sintered bronze E						EEZ-ON® on the Outlet Side 3	
Metal (295 ml) - Lubricator 53E		20 µm Sintered bronze F						EEZ-ON® on the Inlet Side (choose also reverse flow) 4	
Plastic (177 ml) - on Filter 53F								Blank - No L-O-X®	
Metal (295 ml) - Lubricator 53F									
ADJUSTMENT RANGE									
0 - 13,8 bar A									
0 - 10,3 bar B									
0 - 6,9 bar C									
0 - 3,4 bar D									
Reverse Flow, 0 - 13,8 bar F									
Reverse Flow, 0 - 10,3 bar G									
Reverse Flow, 0 - 6,9 bar H									
Reverse Flow, 0 - 3,4 bar J									

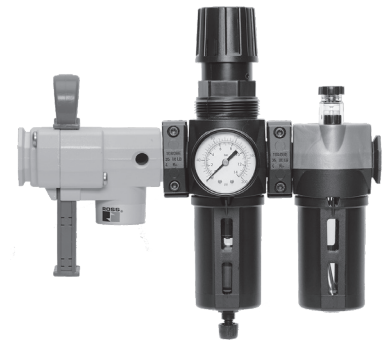
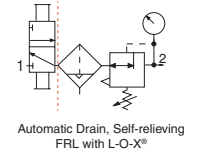

REPLACEMENT FILTER ELEMENTS*		
Element Rating	Material	Part Number
5 µm	Polyethylene	R-A60F-03PE5
5 µm	Sintered bronze	R-A60F-03E5
20 µm	Sintered bronze	R-A60F-03E4
40 µm	Sintered bronze	R-A60F-03E3

* For Polycarbonate and Metal bowl types.

Accessories ordered separately, see Pages 30 - 32.

STANDARD SPECIFICATIONS (for all products on this page)

Construction: Filter: Fiber or sintered bronze; Regulator: Diaphragm; Lubricator: Sight-feed.

Ambient/Media Temperature:

Polycarbonate bowl: 4° to 52°C.

Metal bowl: 4° to 80°C.

Flow Medium: Compressed air.

Filter Inlet Pressure

Polycarbonate bowl & manual drain: 0 - 10 bar,

Metal bowl & manual drain: 0 - 17.

Polycarbonate bowl & float drain: 2 - 10 bar,

Metal bowl & float drain: 2 - 14 bar.

Lubricator Inlet Pressure:

Polycarbonate bowl: 10 bar, max.

Metal bowl: 17 bar, max.

Outlet Pressure: Adjustable up to 14 bar.

Pressure Adjustment Locking Key (optional): Removable.

Pressure Gauge: 0 - 14 bar; G 1/4 (or 1/4" NPT) gauge ports, front and rear.

Panel Mounting: 52 mm hole required.

Oil Adjustment: External; tamper resistant.

Filter Element: Polyethylene: 5-micron rated;

Sintered bronze: 5-, 20-, or 40-micron rated.

Body: Zinc.

Dome: Nylon.

Bowl: Polycarbonate bowl with Nylon shatterguard;

Aluminum bowl with clear nylon sight glass.

Lubricator bowl only: Extended aluminum bowl with clear nylon sight glass.

Seals: Nitrile.

Valve: Brass.

Sight-Feed Dome: Nylon.

IMPORTANT NOTE: Please read carefully and thoroughly all of the **CAUTIONS, WARNINGS** on Pages 33 and 34

Integrated Filter/Regulator & Lubricator Combinations

Series MD3™

Bowl Type	Dimensions mm				Weight ♦ kg
	A	B*	C	Depth ♦	
Polycarbonate	164,1	140,6	119	73,7	2,1
Metal (Alu)	164,1	163,1	119	73,7	2,3
Extended Metal Bowl (Alu)	164,1	238	119	73,7	2,4

L-O-X® Valve: With the lockout valve, add 102 mm to Dimension A.
 * Bowl (standard) removal clearance: add 79 mm.
 Bowl (extended) removal clearance: add 155 mm.
 ♦Less gauge.

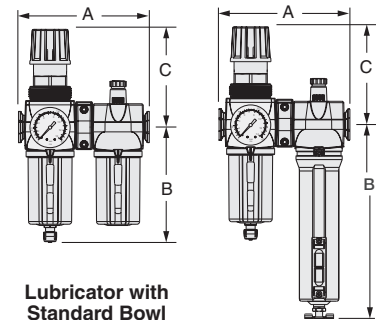

Lubricator with Standard Bowl

Lubricator with extended Metal Bowl

FLOW CHARTS

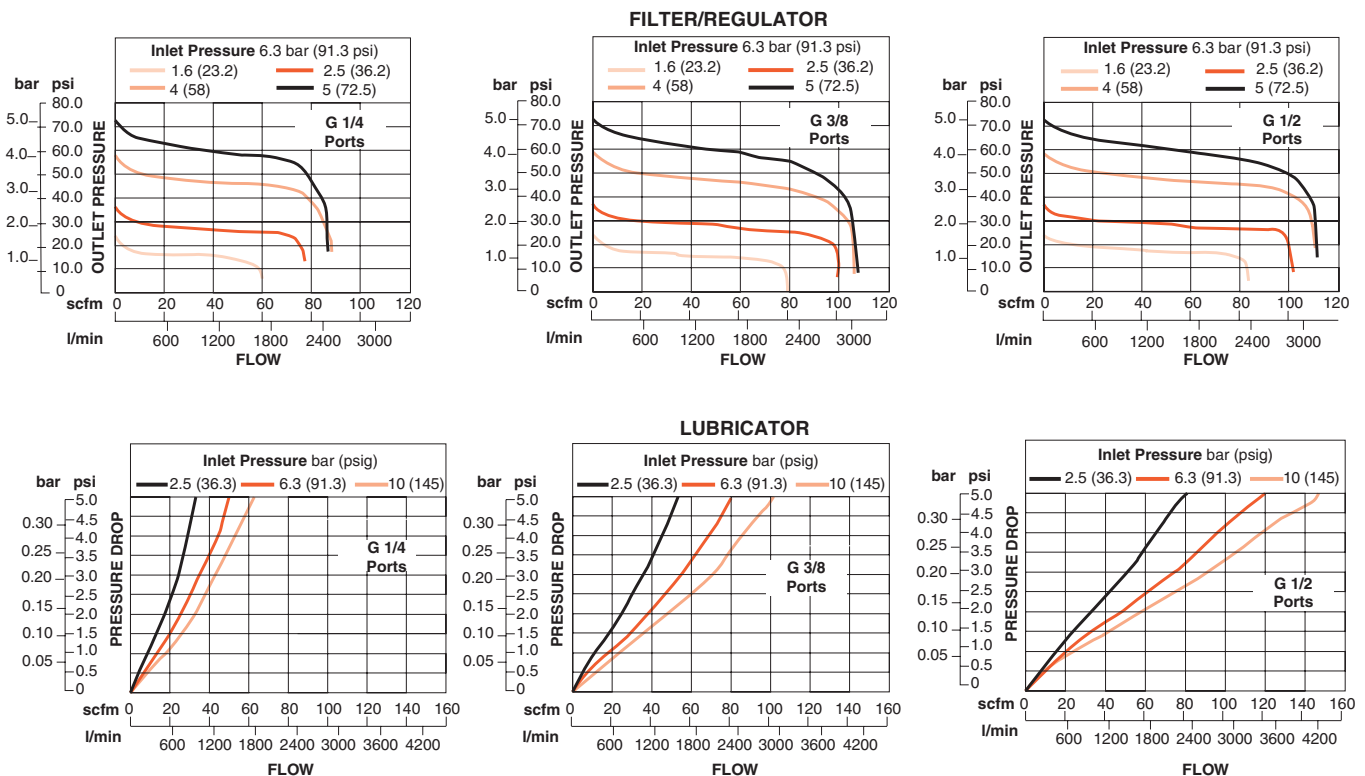

IMPORTANT NOTE: Please read carefully and thoroughly all of the **CAUTIONS, WARNINGS** on Pages 33 and 34

Filter, Regulator and Lubricator Combinations

Series MD3™

G 1/4, G 3/8 & G 1/2 – Flow to 3100 l/min

HOW TO ORDER

(Choose your options in **RED** to configure your model number)

MD3	53P	B	A	6	C	B	2	Q	1
BOWL TYPE		BOWL DRAIN		PORT SIZE		CAP COLOR		OIL FILLING	
Polycarbonate (151 ml) 53P		Manual 6		G 1/4 B		Gold 2		Quick Fill Q	
Metal (177 ml) 53M		Float 9		G 3/8 C		Gray G		Cap S	
Metal (177 ml) - Filter 53E				G 1/2 D		Yellow Y		Fill Port S	
Metal (295 ml) - Lubricator 53E				1/4 NPT 2		Red R			
Plastic (177 ml) - Filter 53F				3/8 NPT 3		Blue B			
Metal (295 ml) - Lubricator 53F				1/2 NPT 4					
ADJUSTMENT RANGE		FILTER ELEMENT		L-O-X® VALVE (optional)					
0 - 13,8 bar A		40 µm Sintered bronze A		L-O-X® on Outlet Side 1					
0 - 10,3 bar B		5 µm Polyethylene B		L-O-X® on the Inlet Side (must also choose Reverse Flow) 2					
0 - 6,9 bar C		5 µm Sintered bronze E		EEZ-ON® on Outlet Side 3					
0 - 3,4 bar D		20 µm Sintered bronze F		EEZ-ON® on Inlet Side (must also choose Reverse Flow) 4					
No Regulator E				Blank - No L-O-X®					
Reverse Flow, 0 - 13,8 bar F									
Reverse Flow, 0 - 10,3 bar G									
Reverse Flow, 0 - 6,9 bar H									
Reverse Flow, 0 - 3,4 bar J									

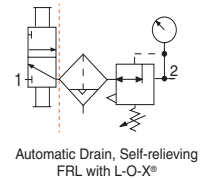
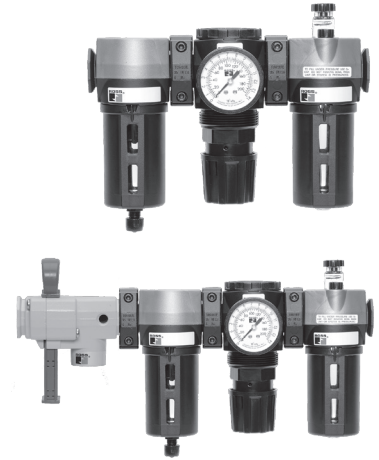

REPLACEMENT FILTER ELEMENTS*		
Element Rating	Material	Part Number
5 µm	Polyethylene	R-A60F-03PE5
5 µm	Sintered bronze	R-A60F-03E5
20 µm	Sintered bronze	R-A60F-03E4
40 µm	Sintered bronze	R-A60F-03E3

* For Polycarbonate and metal bowl types.

Options: External Bowl Drains, for additional information, see Page 32.
Accessories ordered separately, see Page 30 - 32.

STANDARD SPECIFICATIONS (for all products on this page)

Construction: Filter: Fiber, or Sintered Bronze; Regulator: Diaphragm; Lubricator: Sight-Feed.
Ambient/Media Temperature:
 Polycarbonate bowl: 4° to 52°C.
 Metal bowl: 4° to 80°C.
Differential Pressure Gauge: Optional.
Flow Medium: Compressed air.
Filter Inlet Pressure:
 Polycarbonate bowl & manual drain: 0 - 10 bar,
 Metal bowl & manual drain: 0 - 17.
 Polycarbonate bowl & float drain: 2 - 10 bar,
 Metal bowl & float drain: 2 - 14 bar.
Outlet Pressure: Adjustable to 13 bar.
Optional Pressure Adjustment Locking Key: Removable.
Pressure Gauge: 0 to 14 bar; G 1/4 (or 1/4" NPT) gauge ports, front and rear.
Panel Mounting: 52 mm hole required.

Self-relieving: Non-relieving optional.
Oil Adjustment: External; tamper resistant.
Filter Element: Polyethylene: 5-Micron; Sintered bronze: 5-, 20-, or 40-Micron.
Body: Zinc.
Dome: Nylon.
Regulator - Dome: Nylon.
Knob: Acetal.
Bowl: Polycarbonate with nylon shatterguard; Aluminum bowl with clear nylon sight glass. Lubricator bowl only: Extended aluminum bowl with clear nylon sight glass.
Seals: Nitrile.
Valve: Brass.
Valve Cap: Nylon.
Sight-Feed Dome: Nylon

IMPORTANT NOTE: Please read carefully and thoroughly all of the **CAUTIONS, WARNINGS** on Pages 33 and 34

Filter, Regulator and Lubricator Combinations

Series MD3™

Port Size	Bowl	Dimensions mm				Weight kg
		A	B*	C	Depth	
G 1/4	Polycarbonate	247,4	140,6	56,2	73,7	2,8
G 3/8	Aluminum	247,4	163,1	56,2	73,7	2,9
G 1/2	Extended Aluminum	247,4	238	56,2	73,7	3,0

L-O-X® Valve: add 102 mm to Dimension A.
 * Standard bowl removal clearance: add 79 mm.
 Extended bowl removal clearance: add 155 mm.
 Dimensions above reflect less gauge.

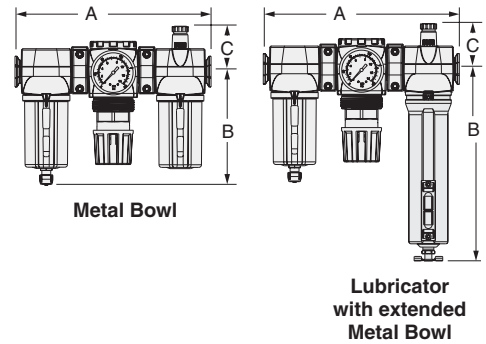

FLOW CHARTS

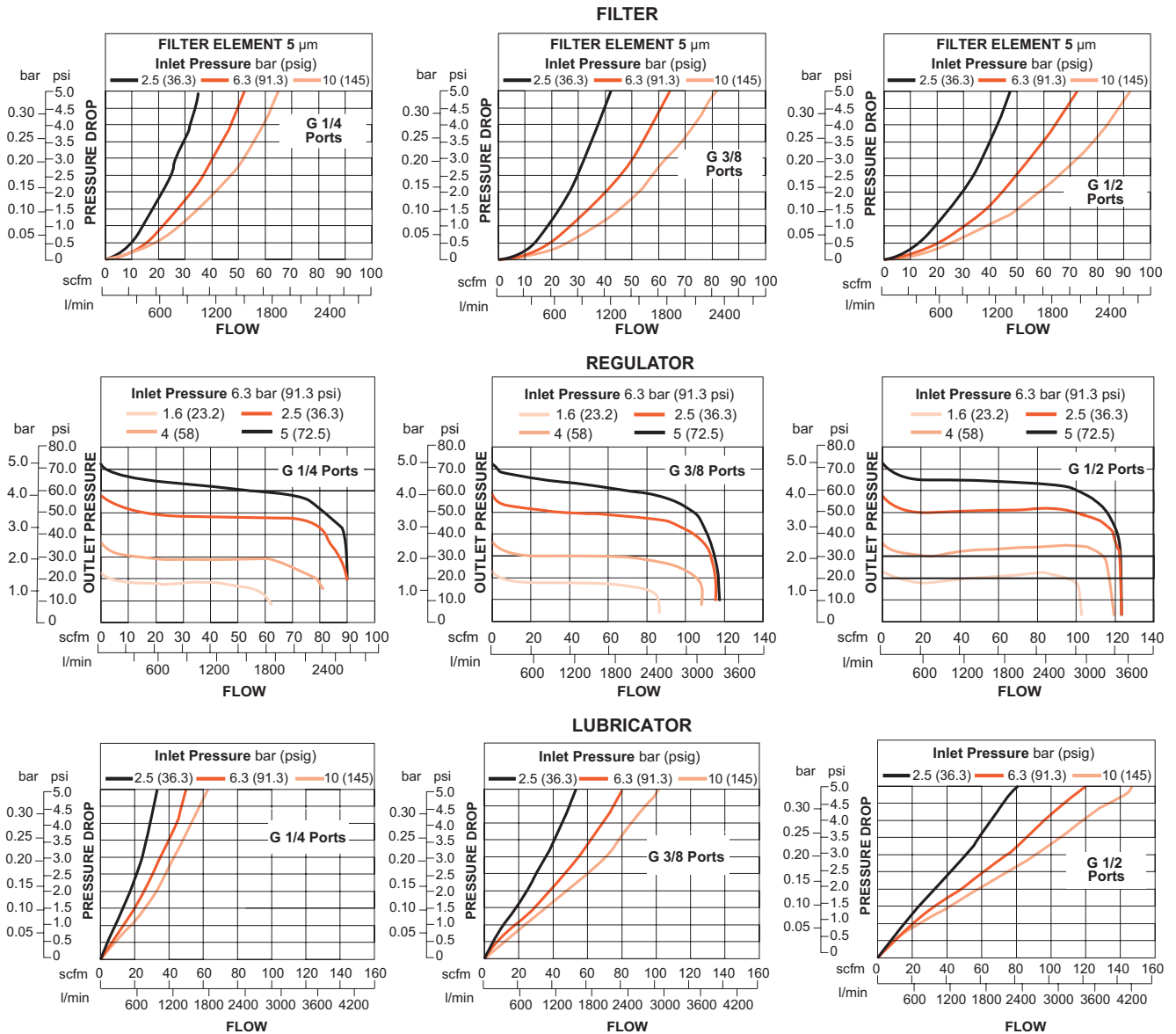

IMPORTANT NOTE: Please read carefully and thoroughly all of the **CAUTIONS, WARNINGS** on Pages 33 and 34



FRL - Line Extension Series MD4™

- G 3/8 to G 3/4
- Flow-rating up to 5800 l/min
- Modern, aesthetically pleasing design
- Modular design
- Rugged construction

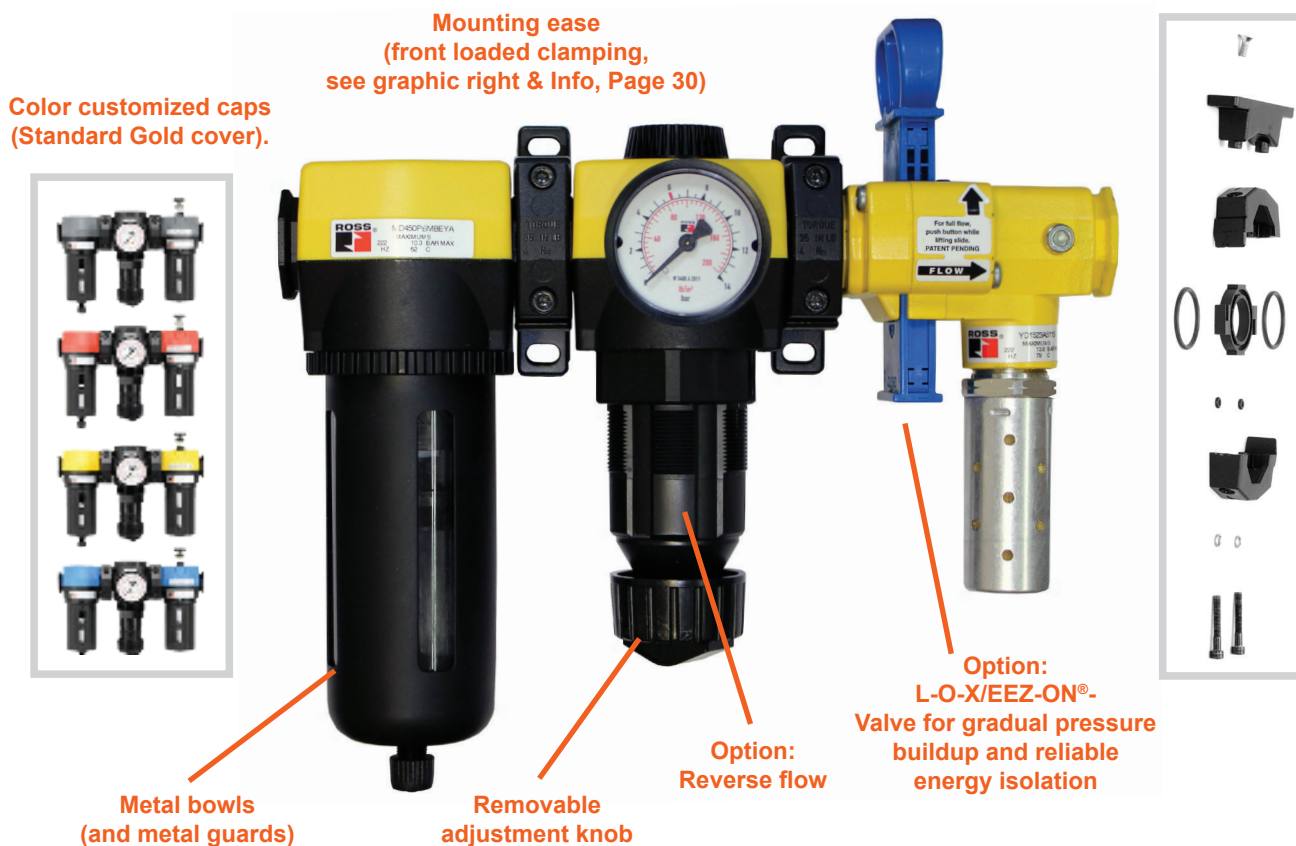

Designed and tested to ISO 5782-2,
ISO 6301-2 and ISO 6953-1 Standards.

OVERVIEW

FILTERS.....	Page 17 – 18
"CLEAN AIR" PACKAGE.....	Page 19 – 20
REGULATORS	Page 21 – 24
LUBRIACTORS	Page 25
COMBINATIONS.....	Page 26 – 29
ACCESSORIES	Page 30 – 32

Spare Part Information

Consult
ROSS EUROPA®
or your nearest
ROSS® Service Point
for Details.

G 3/8, G 1/2 & G 3/4 – Flow to 5800 l/min



HOW TO ORDER
(Choose your options in **RED** to configure your model number)

MD4 **50P** **B** **A** **B** **E** **2** **L**

BOWL TYPE	
Polycarbonate (266 ml)	50P
Metal (266 ml)	50M

FILTER ELEMENTS	
40 µm Sintered bronze	A
5 µm Polyethylene	B

BOWL DRAIN	
Automatic	A
Manual	M
Less Drain Fitting - (1/4 NPT female instead)	L
Internal Float Drain	F

PORT SIZE	
G 3/8	C
G 1/2	D
G 3/4	E
3/8 NPTF	3
1/2 NPTF	4
3/4 NPTF	5

CAP COLOR	
Gold	2
Gray	G
Yellow	Y
Red	R
Blue	B

DIFFERENTIAL PRESSURE GAUGE	
No Gauge (without gauge port)	A
Large Dual Face Gauge	L
Small Slide Gauge	S
Large Dual Face Gauge, with Normally Open Reed Switch	E
Large Dual Face Gauge, with Normally Closed Reed Switch	C

Port Size	Bowl Type	Dimensions mm				Weight kg
		A	B**	C	Depth	
G 3/8	Polycarbonate	76,2	195	28	73	0,97
G 1/2	Aluminum	76,2	193	28	79	0,97
G 3/4						

**With small differential gauge, add 31 mm to Dimension C.
Bowl removal clearance: add 79 mm.

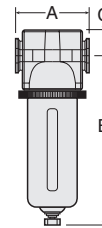

REPLACEMENT FILTER ELEMENTS		
Element Rating	Material	Element Number
5 µm	Polyethylene	R-A115-106PE5
40 µm	Sinter bronze	R-A115-106PE3

FLOW CHARTS

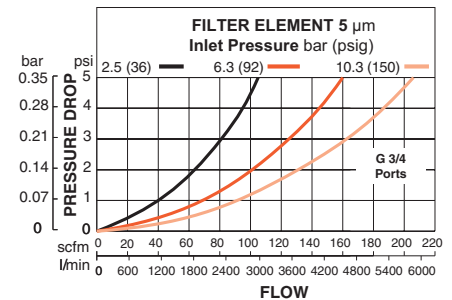
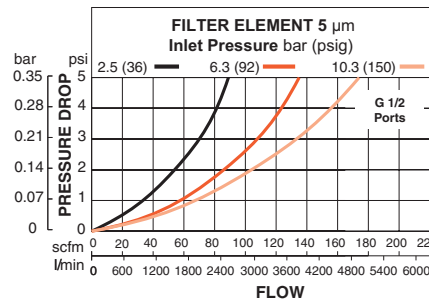
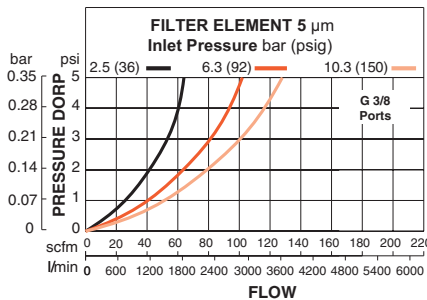

Options: Differential Pressure Gauge, for additional information, see Page 32.

Options: External Bowl Drains, for additional information, see Page 32.

Accessories ordered separately, see Pages 30 - 32.

STANDARD SPECIFICATIONS (for all products on this page)

Construction: Sintered or fiber.
Ambient/Media Temperature:
 Polycarbonate bowl: 4° to 52°C.
 Metal bowl: 4° to 80°C.
Flow Medium: Compressed air.
Inlet Pressure, Automatic drain model:
 Polycarbonate bowl: up to 10 bar.
 Metal bowl: up to 14 bar.

Inlet Pressure, Manual drain model:
 Polycarbonate bowl: 0 to 10 bar.
 Metal bowl: 0 to 14 bar.
Filter Element: Polyethylene: 5 Micron, or Sintered bronze: 40 Micron.
Body: Die-cast zinc.
Bowl: Polycarbonate bowl with steel shatterguard, or aluminum bowl with clear nylon sight glass.
Bowl Ring: Nylon.
Seals: Nitrile

IMPORTANT NOTE: Please read carefully and thoroughly all of the **CAUTIONS, WARNINGS** on Pages 33 and 34

G 3/8, G 1/2 & G 3/4 – Flow to 4450 l/min

HOW TO ORDER

(Choose your options in **RED** to configure your model number)

MD4 **50P** **C** **A** **B** **E** **2** **L**

BOWL TYPE	
Polycarbonate (266 ml)	50P
Metal (266 ml)	50M
Extended Metal (443 ml)	50E

FILTER ELEMENT	
0,3 µm Borosilicate glass	C
0,01 µm Borosilicate glass	D

DRAIN	
Automatic	A
Manual	M
Less Drain Fitting - (1/4 NPT female instead)	L
Internal Float Drain	F

PORT SIZE	
G 3/8	C
G 1/2	D
G 3/4	E
3/8 NPTF	3
1/2 NPTF	4
3/4 NPTF	5

CAP COLOR	
Gold	2
Gray	G
Yellow	Y
Red	R
Blue	B

DIFFERENTIAL PRESSURE GAUGE	
No Gauge (without gauge port)	A
Large Dual Face Gauge	L
Small Slide Gauge	S
Large Dual Face Gauge with Normally Open Reed Switch	E
Large Dual Face Gauge with Normally Closed Reed Switch	C

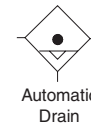

Port Size	Bowl	Dimensions mm				Weight kg
		A	B*	C	Depth	
G 3/8	Polycarbonate	88	195	55	73	0,97
G 1/2	Aluminum	88	193	55	79	0,97
G 3/4	Extended Aluminum	88	284	55	79	1,05

*Bowl removal clearance: add 79 mm. Extended bowl removal clearance: add 155 mm.

REPLACEMENT FILTER ELEMENTS

Elem. Rating	Bowl	Part Number	Elem. Rating	Bowl	Part Number
0,3 µm	Standard	R-A115-117	0,01 µm	Standard	R-A115-117E8
	Extended	R-A115-118		Extended	R-A115-118E8

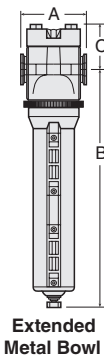
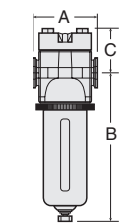

FLOW CHARTS

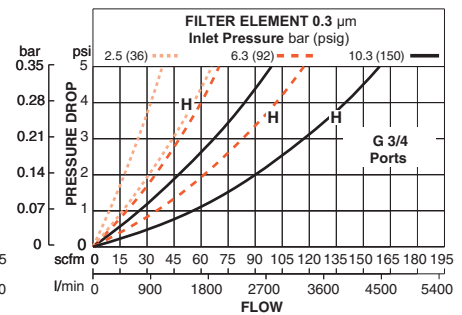
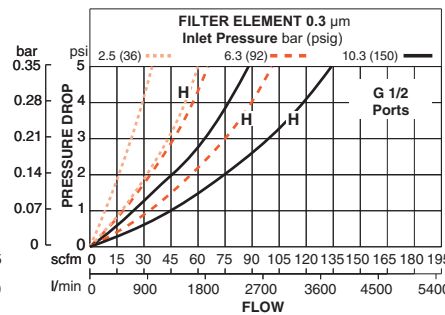
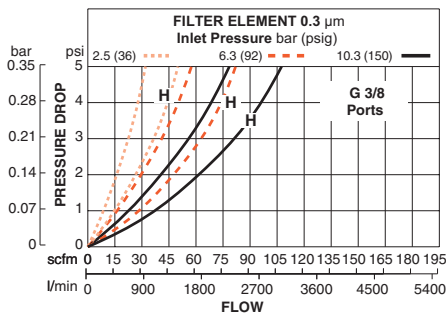

H designates models with extended bowls.

Options: Differential Pressure Gauges: Large Dual Face, Reed-Switch (n.o./n.c.), see Page 32.

Options: External Bowl Drains, additional information, see Page 32. Accessories ordered separately, see Pages 30 - 32.

STANDARD SPECIFICATIONS (for all products on this page)

Construction: Fiber.

Ambient/Media Temperature:

Polycarbonate bowl: 4° to 52°C.

Metal bowl: 4° to 80°C.

Flow Medium: Compressed air.

Inlet Pressure, Automatic drain model:

Polycarbonate bowl: up to 10 bar.

Metal bowl: up to 14 bar.

Inlet Pressure, Manual drain model:

Polycarbonate bowl: 0 to 10 bar.

Metal bowl: 0 to 14 bar.

Filter Element: Borosilicate-glass-fiber, coalescing filter element, 0,3 Micron (Standard) or 0,01 Micron (optional).

Body: Die-cast zinc.

Bowl: Polycarbonate bowl with steel shatterguard, or aluminum bowl with clear nylon sight glass.

Bowl Ring: Nylon.

Seals: Nitrile.

IMPORTANT NOTE: Please read carefully and thoroughly all of the **CAUTIONS, WARNINGS** on Pages 33 and 34

G 3/8, G 1/2 & G 3/4 – Flow to 4650 l/min



HOW TO ORDER
(Choose your options in **RED** to configure your model number)

MD4 **50P** **B** **E** **2**

BOWL TYPE	
Polycarbonat E (270 ml)	50P
Metal (270 ml)	50M
Ext. Metal Bowl (450 ml)	50E

PORT SIZE	
G 3/8	C
G 1/2	D
G 3/4	E
3/8 NPTF	3
1/2 NPTF	4
3/4 NPTF	5

CAP COLOR	
Gold	2
Gray	G
Yellow	Y
Red	R
Blue	B

Port Size	Bowl Type	Dimensions mm				Weight kg
		A	B*	C	Depth	
G 3/8	Polycarbonate	88	195	28	73	0,97
G 1/2	Aluminum	88	193	28	79	0,97
G 3/4	Extended Aluminum	88	284	28	79	1,05

* Bowl removal clearance: add 79 mm. Extended bowl removal clearance: add 155 mm.

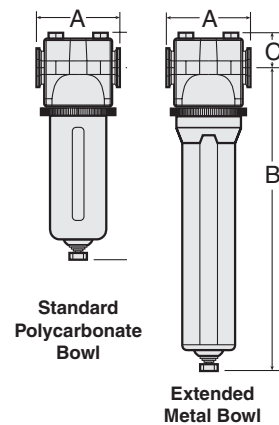

REPLACEMENT FILTER CARTRIDGE		
Filter Rating	Bowl	Part Number
0,01-µm	Standard	R-A115-117E8
	Extended	R-A115-118E8

FLOW CHARTS

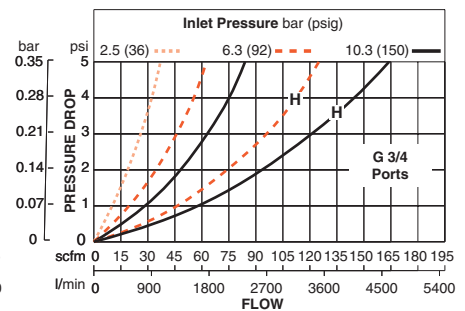
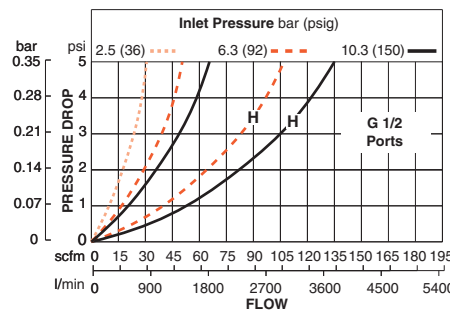
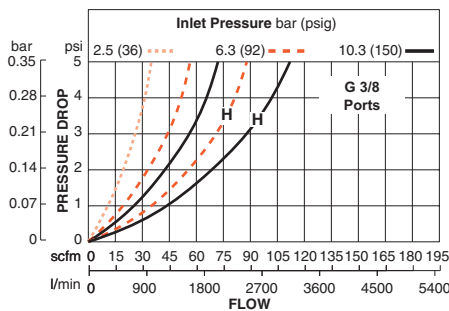

H designates models with extended bowls.

Accessories ordered separately, see Pages 30 - 32.

STANDARD SPECIFICATIONS (for all products on this page)

Construction: Fiber.

Ambient/Media Temperature:

Polycarbonate bowl: 4° to 52°C.

Metal bowl: 4° to 80°C.

Flow Medium: Compressed air.

Inlet Pressure:

Polycarbonate bowl: 0 to 10 bar.

Metal bowl: 0 to 14 bar.

Bowl Drain: Manual.

Filter Cartridge: Activated carbon with urethane seals.

Body: Zinc.

Bowl: Polycarbonate bowl with steel shatterguard, aluminum bowl, or extended aluminum bowl.

Bowl Ring: Nylon.

Seals: Nitrile.

IMPORTANT NOTE: Please read carefully and thoroughly all of the **CAUTIONS, WARNINGS** on Pages 33 and 34

G 3/8, G 1/2 & G 3/4

HOW TO ORDER

(Choose your options in **RED** to configure your model number)

MD4	CAP	1	A	B	1	E	2	L	1
------------	------------	----------	----------	----------	----------	----------	----------	----------	----------

BOWL TYPE	
(3x) Polycarbonate (266 ml)	1
(3x) Metal (266 ml)	2
1x Metal bowl (266 ml) and 2 x Metal bowl (443 ml)	3

COALESCING FILTER	
0,3 µm Borosilicate glass	A
0,01 µm Borosilicate glass	B

BOWL DRAIN	
Manual	1
Internal, automatic (not available on Adsorber)	2
Internal Float drain	F

PORT SIZE	
G 3/8	C
G 1/2	D
G 3/4	E
3/8 NPTF	3
1/2 NPTF	4
3/4 NPTF	5

CAP COLOR	
Gold	2
Gray	G
Yellow	Y
Red	R
Blue	B

L-O-X® VALVE (optional)	
L-O-X® on Outlet Side	1
L-O-X® on Inlet Side	2
EEZ-ON® on Outlet Side	3
EEZ-ON® on Inlet Side	4
No L-O-X®	

DIFFERENTIAL PRESS. GAUGE	
No Gauge (without gauge port)	A
Large Dual Face Gauge	L
Small Slide Gauge	S
Large Dual Face Gauge with, Normally Open Reed Switch	E
Large Dual Face Gauge with, Normally Closed Reed Switch	C

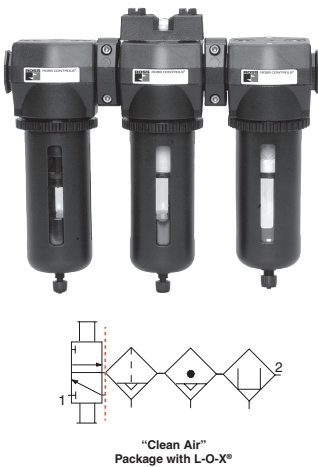

REPLACEMENT FILTER ELEMENTS				
Type	Element Rating	Bowl	Material	Part Number
Filter	5 µm	Standard	Polyethylene	R-A115-106PE5
Coalescing	0,3 µm	Standard	Borosilicate-glass-fiber	R-A115-117
Coalescing	0,3 µm	Extended	Borosilicate-glass-fiber	R-A115-118
Coalescing	0,01 µm	Standard	Borosilicate-glass-fiber	R-A115-117E8
Coalescing	0,01 µm	Extended	Borosilicate-glass-fiber	R-A115-118E8
Adsorbing	Standard Cartridge	Standard	Activated Carbon	R-A115-117E9
Adsorbing	Ext. Standard Cartridge	Extended	Activated Carbon	R-A115-118E9

Accessories ordered separately, see Pages 30 - 32.

STANDARD SPECIFICATIONS (for all products on this page)

Construction: Filter, Coalescing Filter - Fiber.

Polycarbonate bowl: 4° to 52°C.

Metal bowl: 4° to 80°C.

Flow Medium: Compressed air.

Inlet Pressure, Automatic drain model:

Polycarbonate bowl: 1 to 10 bar.

Metal bowl: 1 to 14 bar.

Inlet Pressure, Internal float drain model:

Polycarbonate bowl: 2 to 10 bar.

Metal bowl: 2 to 14 bar.

Inlet Pressure, Manual drain model:

Polycarbonate bowl: 0 to 10 bar.

Metal bowl: 0 to 14 bar.

Filter Drains: Internal automatic drains for general purpose and coalescing filters; manual drain for adsorbing filter. Optional internal float drain on polycarbonate bowl only, consult ROSS.

Filter Elements:

General Purpose: Polyethylene, 5 Micron-rated.

Coalescing: Borosilicate glass-fiber element, 0,3 or 0,01 Micron.

Adsorbing: Activated carbon with urethane seals.

Bowls: Polycarbonate bowls with steel shatterguards; aluminum bowl with clear nylong sight glass on general purpose and coalescing units, or extended aluminum bowls for coalescing and adsorbing filters.

Seals: Nitrile.

IMPORTANT NOTE: Please read carefully and thoroughly all of the **CAUTIONS, WARNINGS** on Pages 33 and 34

Port Size	Bowl	Dimensions mm				Weight kg
		A*	B**	C	Depth	
G 3/8	Polycarbonate	276	195	55	73	3,01
G 1/2	Aluminum	88	195	55	73	3,01
G 3/4	Extended Aluminum	88	284	55	73	3,18

*L-O-X® Valve: add 102 mm to Dimension A.
 **Bowl removal clearance: add 79 mm. Extended bowl removal clearance: add 155 mm.

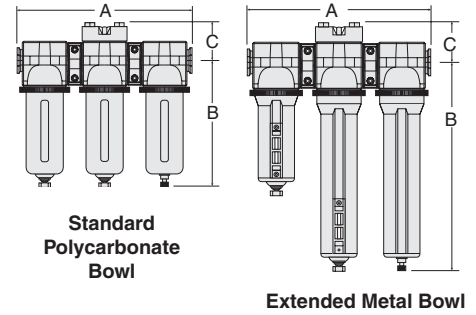

FLOW CHARTS

FILTER

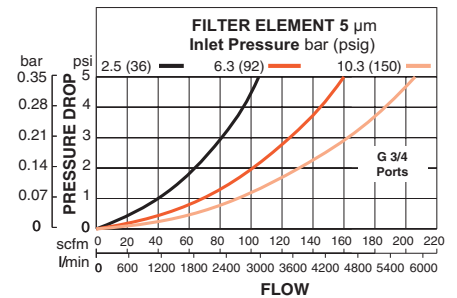
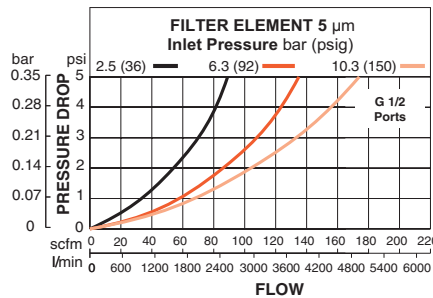
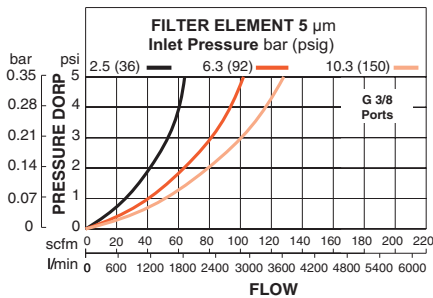

COALESCING FILTER

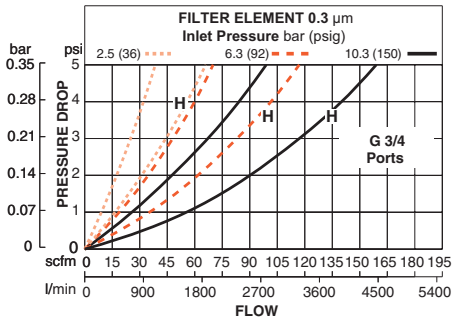
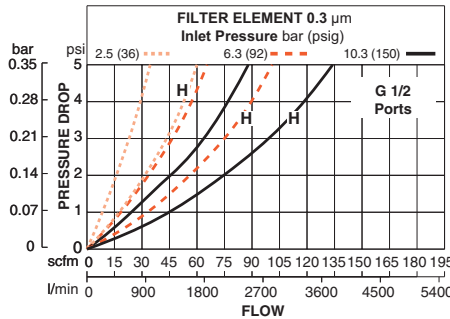
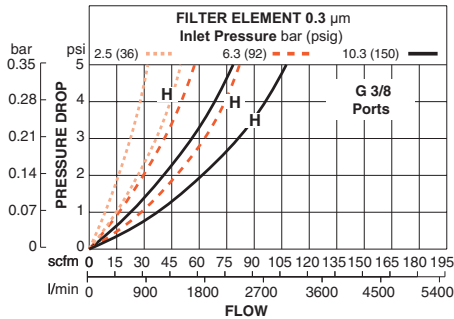

H designates models with extended bowls.

ADSORBING FILTER

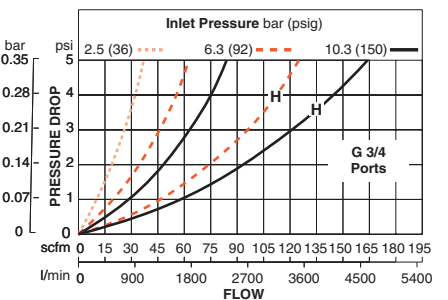
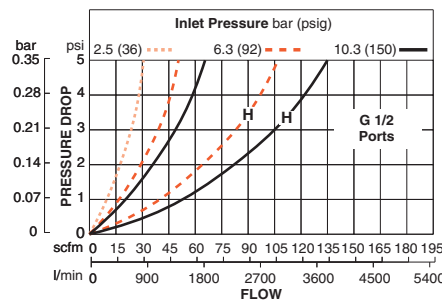
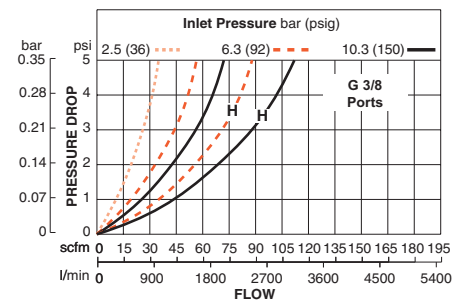

H designates models with extended bowls.

IMPORTANT NOTE: Please read carefully and thoroughly all of the **CAUTIONS, WARNINGS** on Pages 33 and 34

G 3/8, G 1/2 & G 3/4 – Flow to 6200 l/min

HOW TO ORDER

(Choose your options in **RED** to configure your model number)

MD4 **52K** **A** **S** **B** **E** **2** **B**

ADJUSTMENT TYPE	
Knob	52K
Tee Handle	52T

ADJUSTMENT RANGE	
0 - 12,1 bar	A
0 - 8,6 bar	B
0 - 3,4 bar	C
0 - 1,4 bar	D

FLOW OPTIONS	
Reverse Flow	R
Standard	S

PORT SIZE	
G 3/8	C
G 1/2	D
G 3/4	E
3/8 NPTF	3
1/2 NPTF	4
3/4 NPTF	5

CAP COLOR	
Gold	2
Gray	G
Yellow	Y
Red	R
Blue	B

GAUGE	
No Gauge	A
With Gauge (0 - 14 bar)	B
With Gauge (0 - 4 bar)	C
No Gauge, With Panel Mount Nut	D
With Panel Mount Nut & Gauge (0 - 14 bar)	E
With Panel Mount Nut & Gauge (0 - 4 bar)	F

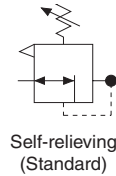

Port Size	Dimensions mm				Weight ♦ kg
	A	B*	C**	Depth ♦	
G 3/8, G 1/2, G 3/4	87	142	40	73	1,16

*Dome removal clearance: 16 mm.
 **Cap removal clearance: 13 mm.
 ♦ Dimensions reflect less gauge.

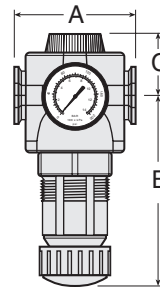

FLOW CHARTS

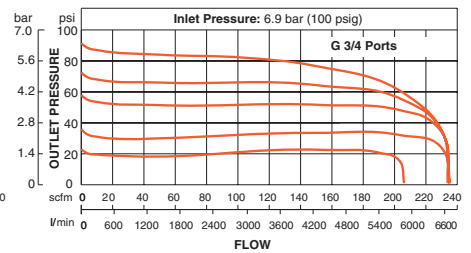
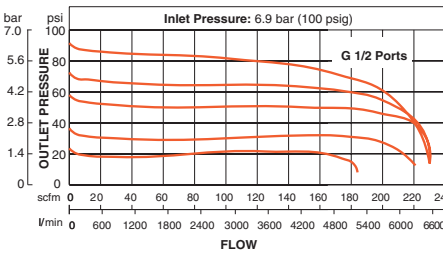
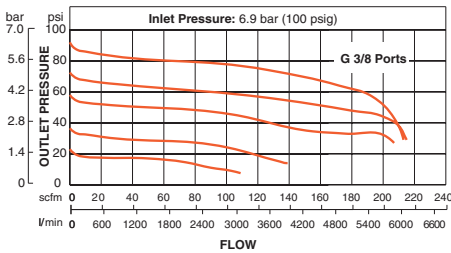

Accessories ordered separately, see Pages 30 - 32.

STANDARD SPECIFICATIONS (for all products on this page)

Construction: Diaphragm. Self-relieving, for non-relieving option consult ROSS.
Ambient/Media Temperature: 4° to 80°C.
Flow Medium: Compressed air.
Inlet Pressure: 21 bar, max.
Outlet Pressure: Adjustable up to 12 bar.
Pressure Adjustment Locking Key: Removable.
Pressure Gauge: 0 to 14 bar; G 1/4 (or 1/4" NPT) gauge ports, front and rear.

Panel Mounting: 52 mm hole required.
Body: Zinc.
Dome: Nylon. Metall (Alu).
Knob: Acetal.
Seals: Nitrile.
Valve: Brass.
Valve Cap: Nylon.

IMPORTANT NOTE: Please read carefully and thoroughly all of the **CAUTIONS, WARNINGS** on Pages 33 and 34

G 3/8, G 1/2 & G 3/4 – Flow to 4800 l/min

HOW TO ORDER
(Choose your options in **RED** to configure your model number)

MD4
52K
E
B
E
2
B

ADJUSTMENT RANGE	PORT SIZE	GAUGE
1,0 - 13,8 bar E	G 3/8 C	No Gauge A
1,0 - 17,2 bar F	G 1/2 D	With Gauge (0 - 14 bar) B
1,0 - 6,9 bar G	G 3/4 E	No Gauge, with Panel Mount Nut D
	3/8 NPTF 3	With Panel Mount Nut & Gauge (0 - 14 bar) E
	1/2 NPTF 4	
	3/4 NPTF 5	

CAP COLOR	
Gold	2
Gray	G
Yellow	Y
Red	R
Blue	B

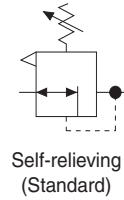

Port Size	Dimensions mm				Weight ♦ kg
	A	B	C	Depth ♦	
G 3/8, G 1/2, G 3/4	87	122	40	73	1,0

♦ Dimensions reflect less gauge.

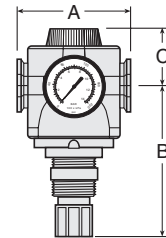

FLOW CHARTS

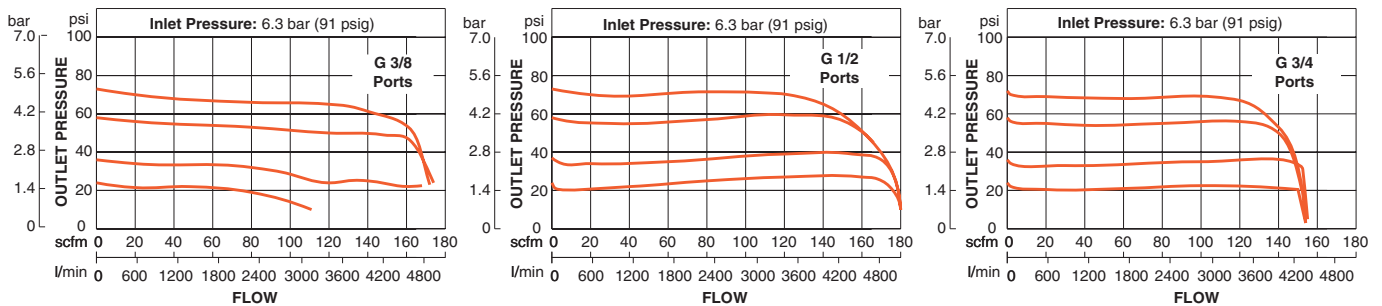

Accessories ordered separately, see Pages 30 - 32.

STANDARD SPECIFICATIONS (for all products on this page)

Construction: Diaphragm,
Self-relieving.

Ambient/Media Temperature: 4° to 52°C.

Flow Medium: Compressed air.

Inlet Pressure: up to 17 bar, max.

Outlet Pressure: Adjustable, 1 to 17 bar.

Pressure Gauge: 0 to 14 bar; G 1/4 (or 1/4" NPT) gauge ports, front and rear.

Panel Mounting: 52 mm hole required.

Body and Dome: Zinc.

Bonnet and Knob: Acetal.

Seals: Nitrile.

Valve: Brass.

Precision Regulators: Provide improved torque control for pneumatic tools; diaphragm type. Pressure settings held within 0,2 bar.

IMPORTANT NOTE: Please read carefully and thoroughly all of the **CAUTIONS, WARNINGS** on Pages 33 and 34

G 3/8, G 1/2 & G 3/4 – Flow to 5400 l/min

HOW TO ORDER

(Choose your options in **RED** to configure your model number)

MD4 **52K** **1** **B** **E** **2** **B**

RELIEF OPTION	
Relieving	1
Non-relieving	2

PORT SIZE	
G 3/8	C
G 1/2	D
G 3/4	E
3/8 NPTF	3
1/2 NPTF	4
3/4 NPTF	5

CAP COLOR	
Gold	2
Gray	G
Yellow	Y
Red	R
Blue	B

GAUGE	
No Gauge	A
With Gauge (0 - 14 bar)	B

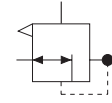

Port Size	Dimensions mm				Weight ♦ kg
	A	B	C	Depth ♦	
G 3/8, G 1/2, G 3/4	87	62	41	73	1,0

♦ Dimensions reflect less gauge.

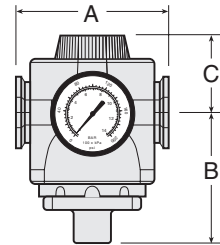

FLOW CHARTS

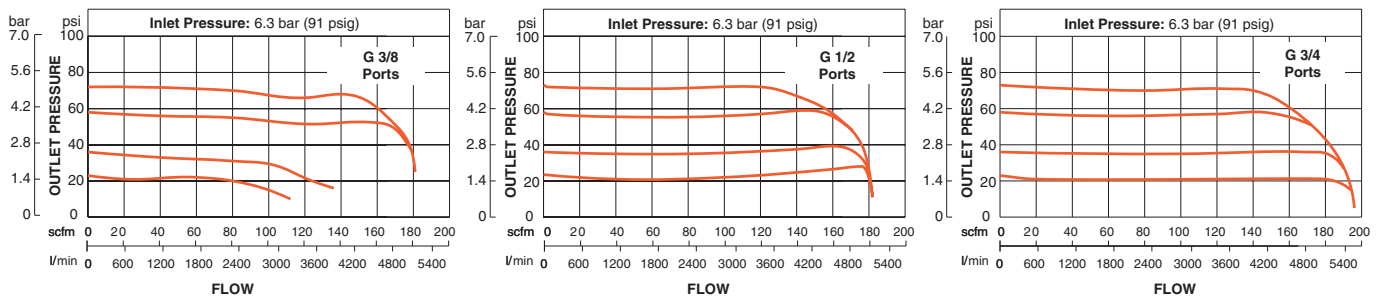

Accessories ordered separately, see Pages 30 - 32.

STANDARD SPECIFICATIONS (for all products on this page)

Construction: Diaphragm, self-relieving.

Ambient/Media Temperature: 4° to 80°C.

Flow Medium: Compressed air.

Inlet Pressure: 21 bar, max.

Outlet Pressure: Adjustable, 0 to 17 bar.

Pilot Port: G 1/4.

Pressure Gauge:

0 to 14 bar; G 1/4 (or 1/4" NPT) gauge ports, front and rear.

Body and Dome: Zinc.

Seals: Nitrile.

Valve: Brass.

Valve Cap: Nylon.

IMPORTANT NOTE: Please read carefully and thoroughly all of the **CAUTIONS, WARNINGS** on Pages 33 and 34

G 3/8, G 1/2 & G 3/4 – Flow to 6500 l/min

HOW TO ORDER

(Choose your options in **RED** to configure your model number)

MD4 **53P** **B** **A** **B** **C** **B** **B** **1**

BOWL	
Polycarbonate (266 ml)	53P
Metal (266 ml)	53M

FILTER ELEMENT TYPE	
40 µm Sintered bronze	A
5 µm Polyethylene	B

DRAIN	
Automatic	A
Manual	M

PORT SIZE	
G 3/8	C
G 1/2	D
G 3/4	E
3/8 NPT	3
1/2 NPT	4
3/4 NPT	5

ADJUSTMENT RANGE	
0 - 12,1 bar	A
0 - 8,6 bar	B
0 - 3,4 bar	C
0 - 1,4 bar	D
Reverse Flow 0 - 12,1 bar	F
Reverse Flow 0 - 8,6 bar	G
Reverse Flow 0 - 3,4 bar	H
Reverse Flow 0 - 1,4 bar	J

L-O-X® VALVE (optional)	
L-O-X® on Outlet Side	1
L-O-X® on Inlet Side	2
(must also choose Reverse Flow)	
L-O-X® & EEZ-ON® on Outlet Side	3
L-O-X® & EEZ-ON® on Inlet Side	4
(must also choose Reverse Flow)	
Blank — No L-O-X®	

GAUGE*	
No Gauge	A
With Gauge 0 - 14 bar	B
With Gauge 0 - 4 bar	C
No Gauge, with Panel Mount Nut	D
With Panel Mount Nut & Gauge 0 - 14 bar	E
With Panel Mount Nut & Gauge 0 - 4 bar	F
*1/4" NPT gauge ports, front and rear	

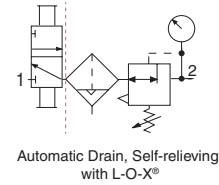

Port Size	Bowl	Dimensions mm				Weight ♦ kg
		A	B*	C**	Depth ♦	
G 3/8, G 1/2, G 3/4	Polycarbonate	88	195	137	73	1,68
G 3/8, G 1/2, G 3/4	Aluminum	88	193	137	73	1,68

L-O-X® Valve: Add 102 mm to Dimension A. ♦ No Gauge.
 * Bowl removal clearance: Add 79 mm.
 ** Dome removal clearance: Add 16 mm.

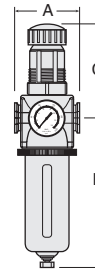

REPLACEMENT FILTER ELEMENTS*		
Element Rating	Material	Element Number
5 µm	Polyethylene	R-A115-106PE5
40 µm	Sintered bronze	R-A115-106PE3

* For Polycarbonate and metal bowls.

FLOW CHARTS

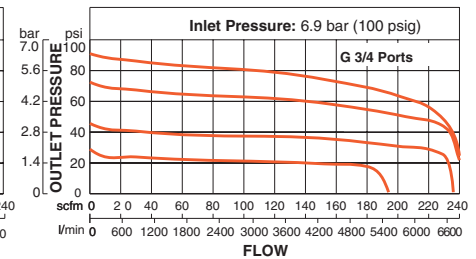
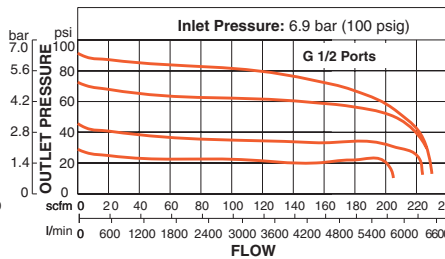
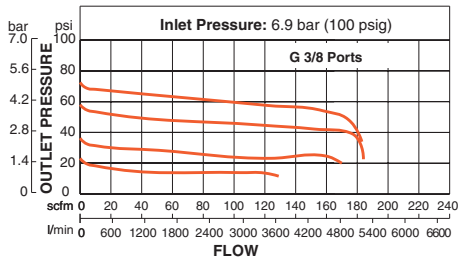

Options: External Bowl Drains, see Page 32. Accessories ordered separately, see Pages 30 - 32.

STANDARD SPECIFICATIONS (for all products on this page)

Construction: Filter: Fiber. Regulator: Piston.

Ambient/Media Temperature:

Polycarbonate bowl: 4° to 52°C.

Metal bowl: 4° to 80°C.

Flow Medium: Compressed air.

Inlet Pressure - Automatic drain models:

Polycarbonate bowl: Up to 10 bar.

Metal bowl: Up to 14 bar.

Inlet Pressure - Manual drain models:

Polycarbonate bowl: 0 to 10 bar.

Metal bowl: 0 to 14 bar.

Outlet Pressure: Adjustable to 9 bar.

Pressure Adjustment Locking Key: Removable.

Panel Mounting: 52 mm hole required.

Filter Element: Polyethylene: 5 Micron; 40 Micron optional.

Body: Zinc.

Bonnet: Nylon, spring optional (0 to 12,1 bar).

Cap Color: Black.

Bowl: Polycarbonate with steel shatterguard, or aluminum bowl with clear nylon sight glass.

Seals: Nitrile.

Valve: Brass.

IMPORTANT NOTE: Please read carefully and thoroughly all of the **CAUTIONS, WARNINGS** on Pages 33 and 34

G 3/8, G 1/2 & G 3/4 – Flow to 5800 l/min



HOW TO ORDER

(Choose your options in **RED** to configure your model number)

MD4 **51P** **Q** **B** **C** **2**

BOWL	
Polycarbonate (266 ml)	51P
Metal (266 ml)	51M
Extended Metal Bowl (443 ml)	51E

LUBRICATOR FILL TYPE	
Quick Fill Cap	Q
Fill Port	S

PORT SIZE	
G 3/8	C
G 1/2	D
G 3/4	E
3/8 NPT	3
1/2 NPT	4
3/4 NPT	5

CAP COLOR	
Gold	2
Gray	G
Yellow	Y
Red	R
Blue	B

Port Size	Bowl	Dimensions mm				Weight kg
		A	B**	C	Depth	
G 3/8, G 1/2, G 3/4	Polycarbonate	88	179	56	73	0,91
	Aluminum	88	188	56	79	0,91

** Bowl removal clearance: add 79 mm.
Extended Bowl removal clearance: add 155 mm.

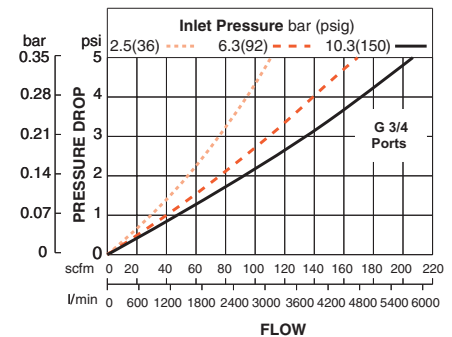
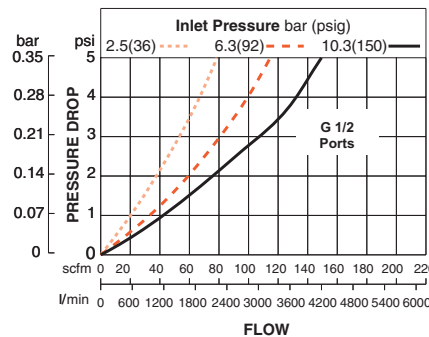
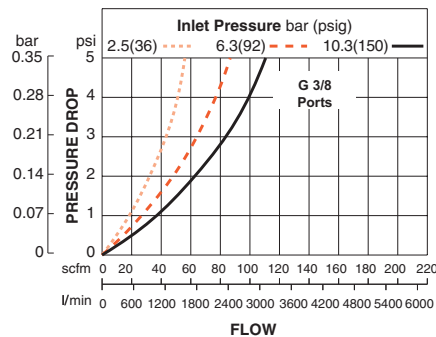
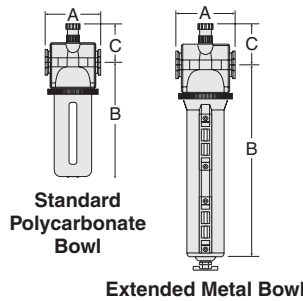
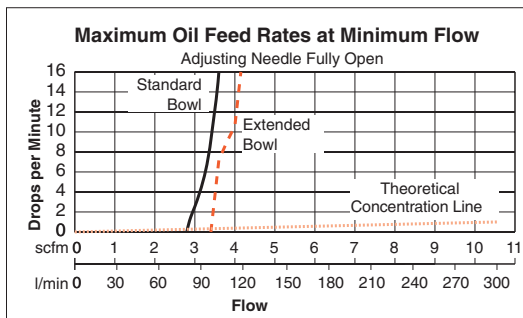

Accessories ordered separately, see Pages 30 - 32.

STANDARD SPECIFICATIONS (for all products on this page)

Construction: Sight-Feed.

Ambient/Media Temperature:

Polycarbonate bowl: 4° to 52°C.

Metal bowl: 4° to 80°C.

Flow Medium: Compressed air.

Inlet Pressure:

Polycarbonate bowl: 10 bar.

Metal bowl: 14 bar.

Oil Adjustment: External; tamper resistant.

Body: Zinc.

Bowl: Polycarbonate with steel shatterguard, aluminum bowl with clear nylon sight glass, or extended aluminum bowl with clear nylon sight glass (2x).

Bowl Ring: Nylon.

Sight-Feed Dome: Nylon.

Seals: Nitrile.

IMPORTANT NOTE: Please read carefully and thoroughly all of the **CAUTIONS, WARNINGS** on Pages 33 and 34

Integrated Filter/Regulator & Lubricator Combinations

Series MD4™

G 3/8, G 1/2 & G 3/4 – Flow to 5800 l/min

HOW TO ORDER

(Choose your options in **RED** to configure your model number)

MD4 **53P** **A** **B** **1** **B** **E** **2** **Q** **1**

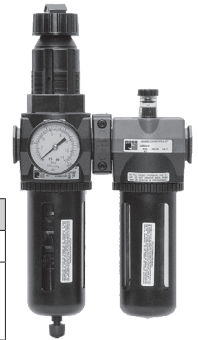
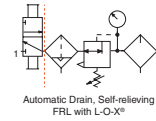

BOWL / MATERIAL	
(2x) Polycarbonate (270 ml)	53P
(2x) Metal (270 ml)	53M
(Filter) Metal (270 ml)	
(Lubricator) Ext. Metal Bowl (450 ml)	53E
(Filter) Plastic (270 ml)	
(Lubricator) Ext. Metal Bowl (450 ml)	53F

ADJUSTMENT RANGE	
0 - 12,1 bar with Gauge 0 - 14 bar	A
0 - 8,6 bar; Standard with Gauge 0 - 14 bar	B
0 - 3,4 bar with Gauge 0 - 4 bar	C
0 - 1,4 bar with Gauge 0 - 4 bar	D
Reverse Flow 0 - 12,1 bar with Gauge 0 - 14 bar	F
Reverse Flow 0 - 8,6 bar; Standard with Gauge 0 - 14 bar	G
Reverse Flow 0 - 3,4 bar with Gauge 0 - 4 bar	H
Reverse Flow 0 - 1,4 bar with Gauge 0 - 4 bar	J

PORT SIZE	
G 3/8	C
G 1/2	D
G 3/4	E
3/8 NPT	3
1/2 NPT	4
3/4 NPT	5

CAP COLOR	
Gold	2
Gray	G
Yellow	Y
Red	R
Blue	B

L-O-X® VALVE (optional)	
L-O-X® on Outlet Side	1
L-O-X® on Inlet Side (must also choose Reverse Flow)	2
EEZ-ON® on Outlet Side	3
EEZ-ON® on Inlet Side (must also choose Reverse Flow)	4
Blank - No L-O-X®	

FILTER-REGUL. - DRAIN	
Automatic	1
Manual	2

FILTER ELEMENT	
40 µm Sintered bronze	A
5 µm Polyethylene	B

LUBRICATOR FILL TYPE	
Quick Fill Cap	Q
Fill Port	S

REPLACEMENT FILTER ELEMENTS*		
Element Rating	Material	Part Number
5 µm	Polyethylene	R-A115-106PE5
40 µm	Sintered bronze	R-A115-106PE3

* For Polycarbonate and Metal Bowl types.

Options: External Bowl Drains, see Page 32.
Accessories ordered separately, see Pages 30 - 32.

STANDARD SPECIFICATIONS (for all products on this page)

Construction: Filter: Fiber or Sintered Bronze, Regulator: Diaphragm. Lubricator: Sight-Feed.

Ambient/Media Temperature:

Polycarbonate bowl: 4° to 52°C.
Metal bowl: 4° to 80°C.

Flow Medium: Compressed air.

Inlet Pressure, Automatic drain models:

Polycarbonate bowl: up to 10 bar.
Metal bowl: up to 14 bar.

Inlet Pressure, Manual drain models:

Polycarbonate bowl: 0 to 10 bar.
Metal bowl: 0 to 14 bar.

Outlet Pressure: Adjustable up to 9 bar.

Filter Element: Polyethylene: 5 Micron; 40 Micron optional.

Head: Zinc.

Pressure Adjustment Locking Key: Removable.

Pressure Gauge: 0 to 14 bar; G 1/4 (or 1/4" NPT) gauge ports, front and rear.

Oil Adjustment: External; tamper-resistant.

Bowl: Aluminum bowl with clear nylon sight glass, polycarbonate bowl with steel shatterguard, or extended aluminum lubricator bowl with clear nylon sight glass.

Regulator Valve: Brass.

Sight Dome: Clear nylon.

Seals: Nitrile.

IMPORTANT NOTE: Please read carefully and thoroughly all of the **CAUTIONS, WARNINGS** on Pages 33 and 34

Integrated Filter/Regulator & Lubricator Combinations

Series MD4™

Pipe Size	Bowl Type	Dimensions mm				Weight ♦ kg
		A	B*	C	Depth ♦	
G 3/8	Polycarbonate	186	195	137	73	2,64
G 1/2	Metal (Aluminum)	186	193	137	73	2,64
G 3/4	Ext. Metal Bowl (Alu)	183	269	119	137	2,73

L-O-X® Valve: With the lockout valve, add 102 mm to Dimension A.
 * Bowl (standard) removal clearance: add 107 mm.
 * Bowl (extended) removal clearance: add 155 mm.
 ♦ Less gauge.

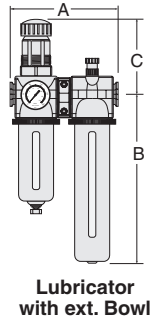
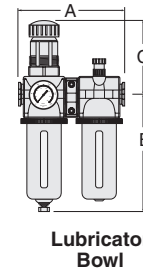

FLOW CHARTS

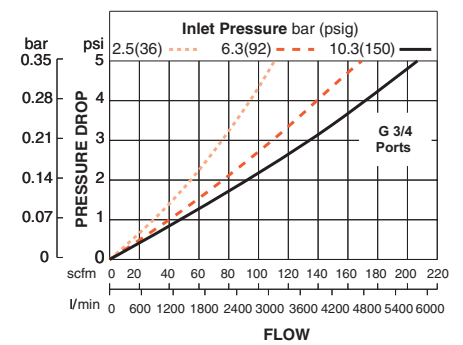
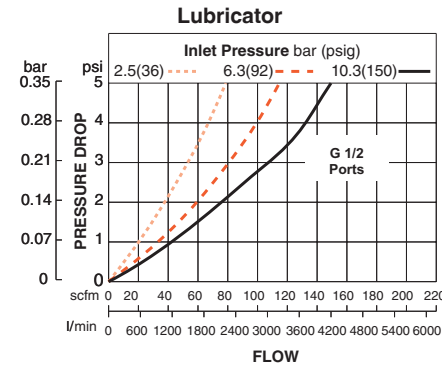
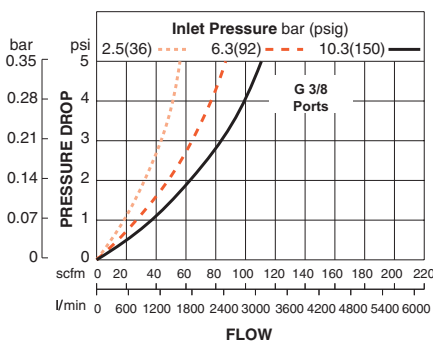
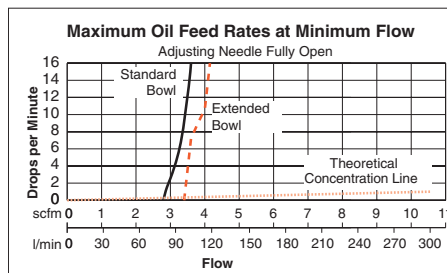
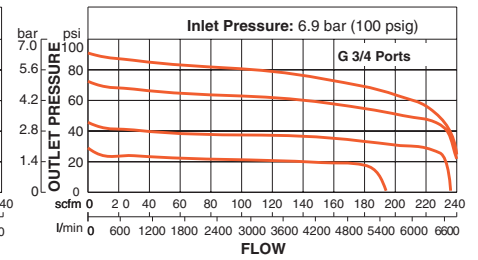
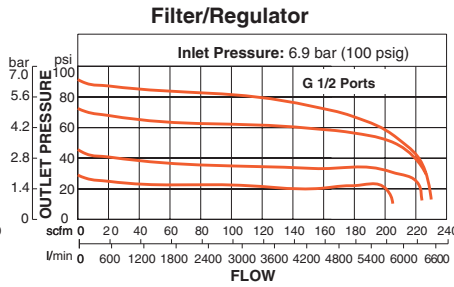
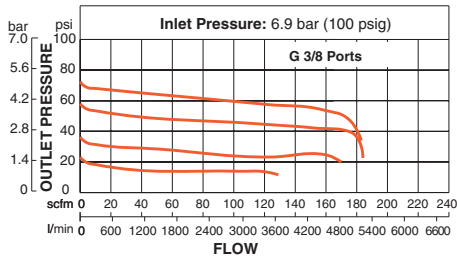

IMPORTANT NOTE: Please read carefully and thoroughly all of the **CAUTIONS, WARNINGS** on Pages 33 and 34

Filter, Regulator and Lubricator Combinations

Series MD4™

G 3/8, G 1/2 & G 3/4 – Flow to 5800 l/min

HOW TO ORDER

(Choose your options in **RED** to configure your model number)

MD4 **53P** **B** **A** **5** **B** **C** **2** **Q** **1**

BOWL TYPE / MATERIAL	
(2x) Polycarbonate (270 ml)	53P
(2x) Metal (270 ml)	53M
Metal (270 ml) - on Filter	
Extended Metal Bowl (450 ml) - on Lubricator	53E
Plastic (270 ml) - on Filter	
Extended Metal Bowl (450 ml) - on Lubricator	53F

REGULATOR ADJUSTMENT	
0 - 12,1 bar	A
0 - 8,6 bar	B
0 - 3,4 bar	C
0 - 1,4 bar	D
No Regulator	E
Reverse Flow	
0 - 12,1 bar	F
Reverse Flow	
0 - 8,6 bar	G
Reverse Flow	
0 - 3,4 bar	H
Reverse Flow	
0 - 1,4 bar	J

FILTER ELEMENT	
40 µm Sintered bronze	A
5 µm Polyethylene	B

FILTER REGULATOR DRAIN	
Automatic	5
Manual	6

PORT SIZE	
G 3/8	C
G 1/2	D
G 3/4	E
3/8 NPT	3
1/2 NPT	4
3/4 NPT	5

CAP COLOR	
Gold	2
Gray	G
Yellow	Y
Red	R
Blue	B

LUBRICATOR FILL	
Quick Fill Cap	Q
Fill Port	S
No Lubricator	N

L-O-X® VALVE (optional)	
L-O-X® on Outlet Side	1
L-O-X® on Inlet Side (must also choose Reverse Flow)	2
EEZ-ON® on Outlet Side	3
EEZ-ON® on Inlet Side (must also choose Reverse Flow)	4
Blank — No L-O-X®	

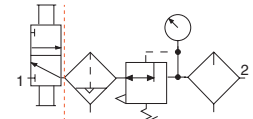

Automatic Drain, Self-relieving FRL with L-O-X®

REPLACEMENT FILTER ELEMENTS*		
Element Rating	Material	Part Number
5 µm	Sintered bronze	R-A115-106PE5
40 µm	Sintered bronze	R-A115-106PE3

* For Polycarbonate and Metal Bowl types.

Options: External Bowl Drains, see Page 32.
Accessories ordered separately, see Pages 30 - 32.

STANDARD SPECIFICATIONS (for all products on this page)

Construction: Filter: Fiber, or Sintered Bronze.
Regulator: Diaphragm. Lubricator: Sight-Feed.

Ambient/Media Temperature:

Polycarbonate bowl: 4° to 52°C.

Metal bowl: 4° to 80°C.

Flow Medium: Compressed air.

Inlet Pressure, Automatic drain model:

Polycarbonate bowl: 1 to 10 bar.

Metal bowl: 1 to 14 bar.

Inlet Pressure, Manual drain model:

Polycarbonate bowl: 0 to 10 bar .

Metal bowl: 0 to 14 bar.

Outlet Pressure: Adjustable up to 9 bar.

Filter Element: Polyethylene: 5 Micron; 40 Micron optional.

Heads: Zinc.

Pressure Adjustment Locking Key: Removable.

Pressure Gauge: 0 to 14 bar; G 1/4 (or 1/4" NPT) gauge ports, front and rear.

Oil Adjustment: External; tamper-resistant.

Bowls: Aluminum bowl with clear nylon sight glass. Polycarbonate bowl with steel shatterguard; extended aluminum lubricator bowl with clear nylon sight glass (2x).

Bowl Ring: Nylon.

Sight Dome: Clear nylon.

Seals: Nitrile.

IMPORTANT NOTE: Please read carefully and thoroughly all of the **CAUTIONS, WARNINGS** on Pages 33 and 34

Filter, Regulator and Lubricator Combinations

Series MD4™

Pipe Size	Bowl Type	Dimensions mm				Weight ♦ kg
		A	B*	C	Depth ♦	
G 3/8	Polycarbonate	276	195	56	73	3,15
G 1/2	Metal	276	193	56	79	3,15
G 3/4	Extended Metal	276	269	56	79	3,24

L-O-X® Valve: With the lockout valve, add 102 mm to Dimension A.
 * Bowl (standard) removal clearance: add 107 mm.
 * Bowl (extended) removal clearance: add 155 mm.
 ♦ Less gauge.

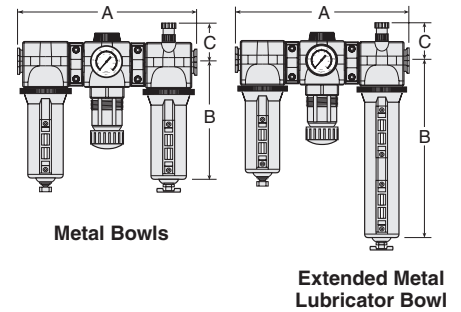

FLOW CHARTS

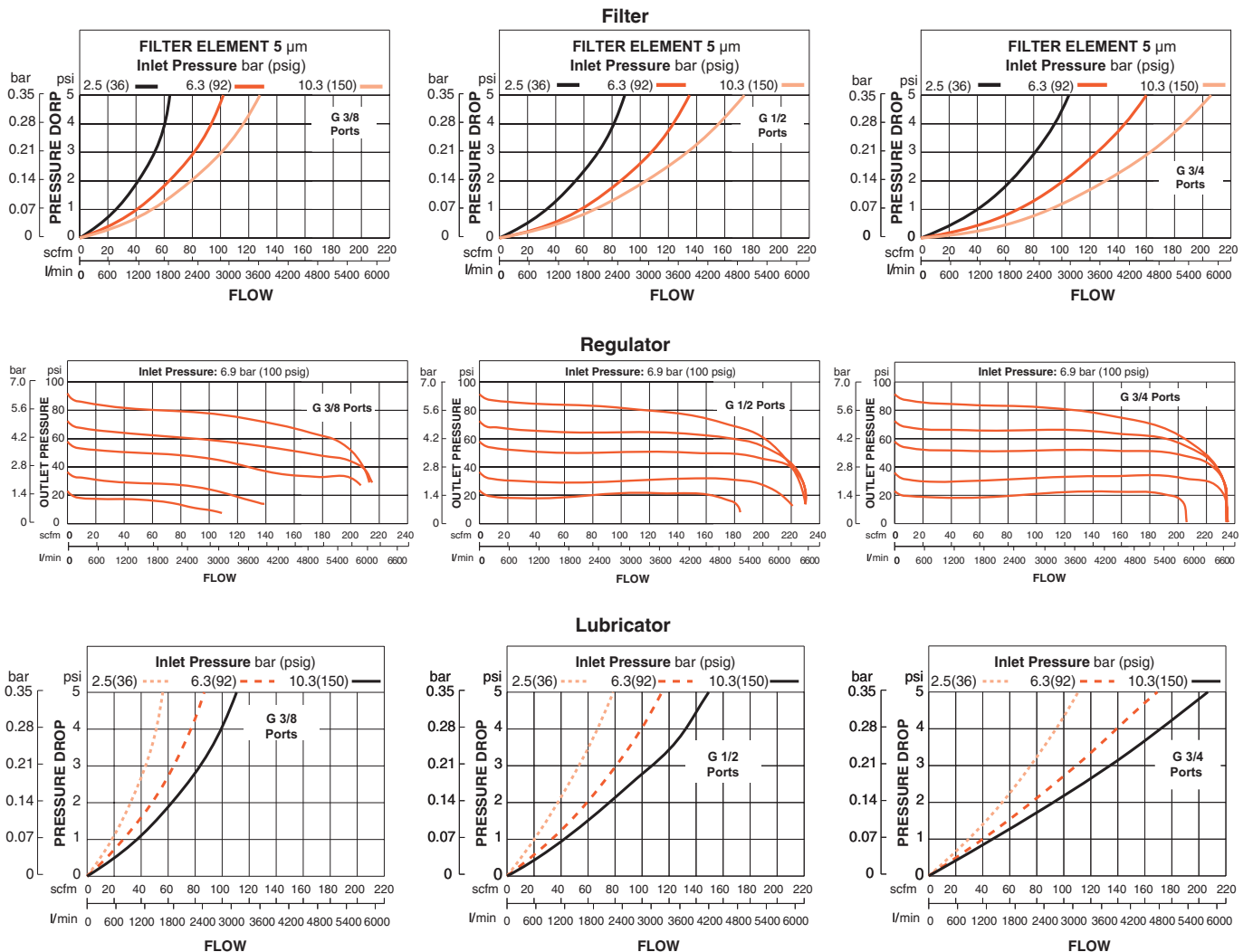

IMPORTANT NOTE: Please read carefully and thoroughly all of the **CAUTIONS, WARNINGS** on Pages 33 and 34

Accessories

Clamps, Brackets, End Ports, Port Blocks

Dimensions - mm

Series MD3™

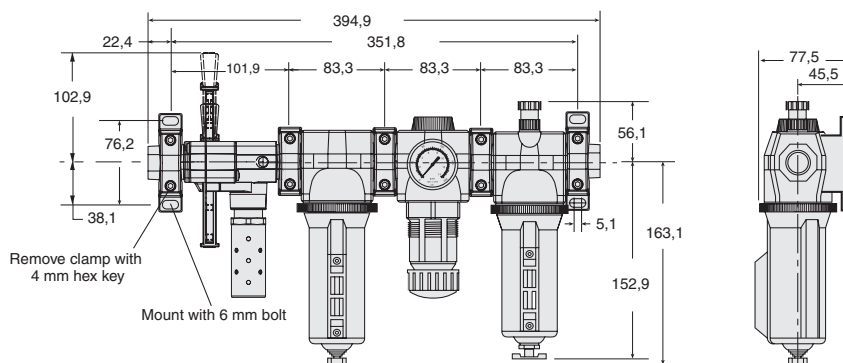

Series MD4™

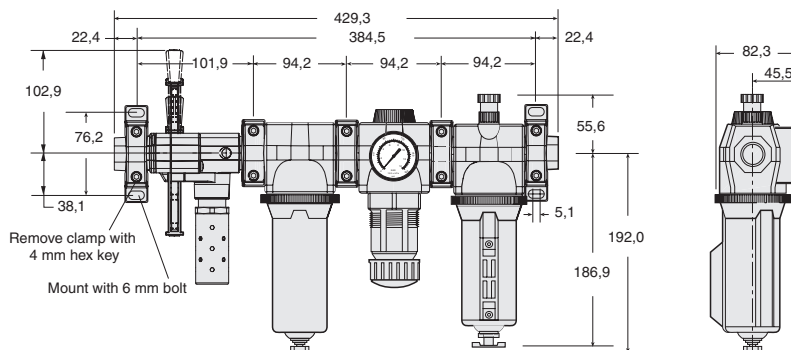



Clamps for Module Connections

Specially designed clamps provide a quick and easy assembly or disassembly of MD3™ modules. Two allen-head bolts quickly tighten or loosen the clamp using a 5/32 or 4 mm hex key. The clamp contains a plate carrying two O-Rings to provide positive sealing between modules.

Part Number: Clamp: **R-A118-105**
 Part Number: Combined clamp and bracket: **R-A118-105M**.

Male and Female End Ports

Either male or female end ports can be attached to threaded inlet and outlet lines. This allows all modules of an FRL assembly to be removed easily and quickly without having to unthread the end modules. The end ports are attached to the modules with clamps (see at left). End ports can be included in an assembled FRL unit or ordered separately by the part numbers given in the chart below:

Port Size	Part Number Male*		Port Size	Part Number Female*	
G 1/4	R-118-109-2FW		G 1/4	R-118-100-2W	
G 3/8	R-118-109-3FW		G 3/8	R-118-100-3W	
G 1/2	R-118-109-4FW		G 1/2	R-118-100-4W	
G 3/4	R-118-109-6FW		G 3/4	R-118-100-6W	

* For NPT threads, letter **W** is deleted from the model number, e.g.: R-118-109-2F.

Mounting Brackets

Two brackets are normally used to mount an FRL to a vertical surface. The mounting bracket attaches to the module connecting clamp with a single screw. Each bracket then employs two bolts (1/4" or 6 mm) to connect the assembly to the mounting surface.

Part No.: Order bracket & screw by part number: **R-A118-103**
 Part No.: Combine bracket and clamp: **R-A118-105M**.

Extra Port Blocks

An extra port block can be placed between modules to provide two auxiliary 1/4 NPTF ports. Its mounting position can be rotated to obtain the most convenient operating orientation. If only one auxiliary port is to be used, the unused port must be closed with a pipe plug (inlet and outlet are not threaded).

Port Size	Part Number*	
G 1/4	R-118-106-2W	
G 3/8	R-118-106-3W	
G 1/2	R-118-106-4W	

* For NPT threads, letter **W** is deleted from the model number, e.g.: R-118-106-2.

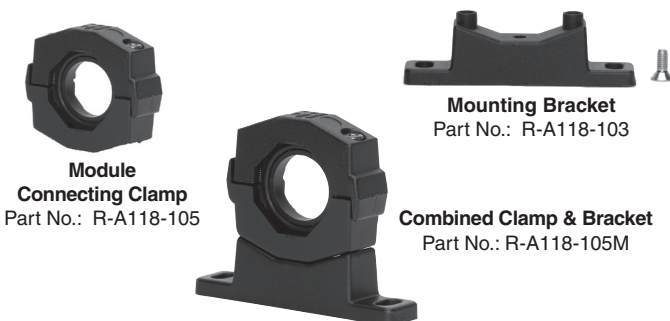

IMPORTANT NOTE: Please read carefully and thoroughly all of the **CAUTIONS, WARNINGS** on Pages 33 and 34

Mounting Brackets for Regulators & Integrated Filter/Regulators

Regulators and integrated filter/regulators can be mounted to a surface with a bracket that attaches to the regulator. Brackets and mounting nuts can be ordered separately or in a kit which includes both bracket and mounting nut.

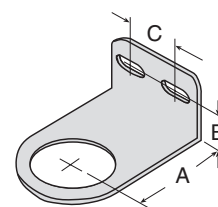

Series	Part Number			Dimensions mm			
	Kit	Bracket	Nut	A	B	C	Panel Mounting Hole Diameter
MD3™	R-A127-11	–	R-127-11	60	25	38	∅ 52
MD4™	879K77	878K77	880K77	60	25	38	∅ 52

FRLs Inline Mounting Pipe Brackets

Two pipe brackets can be used for wall mounting of FRLs assemblies that use pipe nipples to join the components. The bracket kits listed below include two sets of brackets.

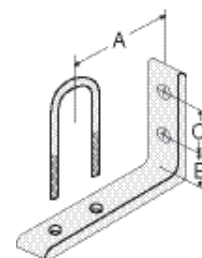

Nipple Size	Kit Number	Dimensions mm		
		A	B	C
1/4	887K77	28	13	25
3/8	888K77	28	13	25
1/2	889K77	28	13	25
3/4	890K77	94	29	32

Silencers

Port Size	Thread Type	Model Number*	Avg. k_v Value	Dimensions mm		Weight kg
				A	B	
G 3/8	Male	D5500A3003	3,7	32	88	0,1
G 3/4	Male	D5500A5013	4,4	32	92	0,1
G 3/4	Male	D5500A5003	10,0	51	135	0,3

* For NPT thread: Delete Prefix D from model number, e.g.: 5500A5013.
Flow Media: Compressed air, filtered (5 micron recommended).
Pressure Range: 0 to 10,3 bar maximum.

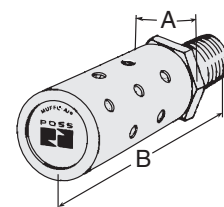

External Automatic Drains

Port Size	Model Number	
	Polycarbonate Bowl*	Metal Bowl
1/4	5057B2001	5058B2001

Use kit 1076K77 to convert standard bowl to accept auto drain unit.
 *Polycarbonate bowl includes metal bowl guard.

Port Size	Dimensions mm			Weight kg
	A	B	C	
1/4	89	107	211	1,2

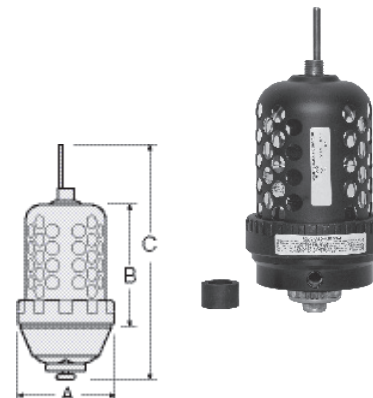

IMPORTANT NOTE: Please read carefully and thoroughly all of the **CAUTIONS, WARNINGS** on Pages 33 and 34

Pressure Gauges

Port Size*	Model Number **	Pressure Range bar	Housing ø mm
G 1/4	W5400A2010	0 - 4	55
G 1/4	W5400A2011	0 - 14	55
G 1/4	W5400A2012	0 - 21	55

* Center back mounting, male pipe threads.
 ** For NPT: delete Prefix "W" from Model Number. Example: 5400A2011.

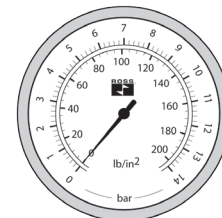

Differential Pressure Gauges

TYPE	Small Slide Gauge	Small Slide Gauge	Large Dual Face Gauge	Large Dual Face Gauge with Reed Switch (Normally Open)	Large Dual Face Gauge with Reed Switch (Normally Closed)
GENERAL PURPOSE FILTERS					
MD3™	R-A60F-28	-	-	-	-
MD4™	-	R-K103-151	R-106-35	R-106-35E	R-106-35C
COALESCING FILTERS					
MD3™	R-A60F-28	-	-	-	-
MD4™	-	R-K103-151	R-106-35	R-106-35E	R-106-35C
"CLEAN AIR" PACKAGES					
MD3™	R-A60F-28	-	-	-	-
MD4™	-	R-K103-151	R-106-35	R-106-35E	R-106-35C

IMPORTANT NOTE: Please read carefully and thoroughly all of the **CAUTIONS, WARNINGS** on Pages 33 and 34

CAUTIONS, WARNINGS



Although air line lubrication is not required for most ROSS® valves, other mechanisms in the system may need such lubrication. When a lubricator is used it should be supplied only with oils which are compatible with the materials used in the valves for seals and poppets. Generally speaking, these are petroleum base oils with oxidation inhibitors, and an aniline point between 82°C and 104°C and viscosity VG 32 according to ISO 3448 (32 mm²/s at 40°C), or lighter. Oils with phosphate type

additives, such as zinc dithiophosphate, must be avoided because they can harm polyurethane valve components. **WARNING:** Hydraulic and synthetic oils may not be used for air line lubrication.

The best oils to use in pneumatic systems are those specifically compounded for air line lubricator service.

CAUTIONS on the Use of Polycarbonate Plastic Bowls

Use only with Compressed Air. Filters and lubricators with polycarbonate plastic bowls are specifically designed for compressed air service, and their use with any other fluid (liquid or gas) is a misapplication. The use with or injection of certain hazardous fluids in the system (e.g. alcohol or liquified petroleum gas) could be harmful to the plastic bowl or result in a combustible condition or hazardous leakage. Before using with a fluid other than air, or for non-industrial applications, or for life support systems, consult ROSS.

Use Metal Bowl Guard When Supplied. A metal bowl guard is supplied with all but the smallest bowls, and must

always be used to minimize danger from fragmentation in the event of failure of a plastic bowl.

Avoid Harmful Substance. Some compressor oils, chemical cleaners, solvents, paints, and fumes will attack plastic bowls and can cause bowl failure. Do not use with or near these materials. When a bowl becomes dirty, replace the bowl or wipe it with a clean dry cloth. Immediately replace any plastic bowl which is crazed, cracked, or deteriorated.

Substances HARMFUL to Polycarbonate Plastic Bowls

Acetaldehyde	Carbon disulfide	Ethylene dichloride	Phosphorous trichloride
Acetic acid	Carbon tetrachloride	Ethylene glycol	Propionic acid
Acetone	Caustic potash solution	Formic acid	Pyridine
Acrylonitrile	Caustic soda solution	Freon (refrigerant & propellant)	Sodium hydroxide
Ammonia	Chlorobenzene	Gasoline (high aromatic)	Sodium sulfide
Ammonium fluoride	Chloroform	Hydrazine	Styrene
Ammonium hydroxide	Cresol	Hydrochloric acid	Sulfuric acid
Ammonium sulfide	Cyclohexanol	Lacquer thinner	Sulfural chloride
Anaerobic adhesives & sealants	Cyclohexanone	Methyl alcohol	Tetrachloräthan
Antifreeze	Cyclohexene	Methylene chloride	Tetrahydronaphtalene
Benzene	Dimethyl formamide	Methylene salicylate	Thiophene
Benzoic acid	Dioxane	Milk of lime (CaOH)	Toluene
Benzyl alcohol	Ethane tetrachloride	Nitric acid	Turpentine
Brake fluids	Ethyl acetate	Nitrobenzene	Xylene
Bromobenzene	Ethyl ether	Nitrocellulose lacquer	Perchlorethylene
Butyric acid	Ethylamine	Phenol	
Carbolic acid	Ethylene chlorohydrin	Phosphorous hydroxil chloride	

Trade Names of Substances HARMFUL to Polycarbonate Plastic Bowls

• Atlas Perma-Guard • Buna N • Cellulube #150 & #220 • Crylex #5 cement • Eastman 910 • Garlock 98403 (polyurethane)
• Haskel 568-023 • Hilgard's hil phene • Houghton & Co. oil 1120, 1130, 1055 • Houtosafe 1000 • Kano Kroil • Keystone penetrating oil #2 • Loctite 271, 290, 601 • Loctite Teflon sealant • Marvel Mystery Oil • Minn. Rubber 366Y • National Compound N11 Nylock VC-3 • Parco 1306 Neoprene • Permabond 910 • Petron PD287 • Prestone • Pydraul AC • Sears Regular Motor Oil • Sinclair oil "Lily White" • Stauffer Chemical FYRQUEL 150 • Stillman SR 269-75 (polyurethane) • Stillman SR 513-70 (neoprene) • Tannergas • Telar • Tenneco anderol 495 & 500 oils • Titon • Vibra-tite • Zerex

IMPORTANT NOTE: Because we cannot list all substances harmful to polycarbonate plastic, consult the petrochemical industry for further information.

CAUTIONS, WARNINGS



PRE-INSTALLATION or SERVICE

1. Before servicing a valve or other pneumatic component, be sure that all sources of energy are turned off, the entire pneumatic system is shut off and exhausted, and all power sources are locked out (ref.: EN 1037).
2. All ROSS products, including service kits and parts, should be installed and/or serviced only by persons having training and experience with pneumatic equipment. Because any installation can be tampered with or need servicing after installation, persons responsible for the safety of others or the care of equipment must check every installation on a regular basis and perform all necessary maintenance.
3. All applicable instructions should be read and complied with before using any fluid power system in order to prevent harm to persons or equipment. In addition, overhauled or serviced valves must be functionally tested prior to installation and use.
4. Each ROSS product should be used within its specification limits. In addition, use only ROSS parts to repair ROSS products.

WARNING: Failure to follow these directions can adversely affect the performance of the product or result in the potential for human injury or damage to property.

FILTRATION and LUBRICATION

5. Dirt, scale, moisture, etc. are present in virtually every air system. Although some valves are more tolerant of these contaminants than others, best performance will be realized if a filter is installed to clean the air supply, thus preventing contaminants from interfering with the proper performance of the equipment. ROSS recommends a filter with a 5-micron rating for normal applications.
6. All standard ROSS filters and lubricators with polycarbonate plastic bowls are designed for compressed air applications only. Do not fail to use the metal bowl guard, where provided, to minimize danger from high pressure fragmentation in the event of bowl failure. Do not expose these products to certain fluids, such as alcohol or liquefied petroleum gas, as they can cause bowls to rupture, creating a combustible condition, hazardous leakage, and the potential for human injury or damage to property. Immediately replace a crazed, cracked, or deteriorated bowl. When bowl gets dirty, replace it or wipe it with a clean dry cloth.
7. Only use lubricants which are compatible with materials used in the valves and other components in the system. Normally, compatible lubricants are petroleum based oils

with oxidation inhibitors, an aniline point between 82°C and 104°C, and an ISO 32, or lighter, viscosity. Avoid oils with phosphate type additives which can harm polyurethane components, potentially leading to valve failure which risks human injury, and/or damage to property.

We strongly recommend to use only oils in your pneumatic system which are specifically compounded for air line lubricator service.

AVOID INTAKE / EXHAUST RESTRICTION

8. Do not restrict the air flow in the supply line. To do so could reduce the pressure of the supply air below the minimum requirements for the valve and thereby cause erratic action.
9. Do not restrict a valve's exhaust port as this can adversely affect its operation. Exhaust silencers must be resistant to clogging and must have flow capacities at least as great as the exhaust capacities of the valves. Contamination of the silencer can result in reduced flow and increased back pressure.

WARNING: ROSS expressly disclaims all warranties and responsibility for any unsatisfactory performance or injuries caused by the use of the wrong type, wrong size, or an inadequately maintained silencer installed with a ROSS product.

POWER PRESSES

10. Mechanical power presses (ref.: EN 692) and other potentially hazardous machinery using a pneumatically controlled clutch and brake mechanism must use a press control double valve with a monitoring device. A double valve without a self-contained monitoring device should be used only in conjunction with a control system which assures monitoring of the valve. All double valve installations involving hazardous applications should incorporate a monitoring system which inhibits further operation of the valve and machine in the event of a failure within the valve mechanism.

ENERGY ISOLATION / EMERGENCY STOP

11. Per specifications and regulations, ROSS L-O-X® valves and L-O-X® valves with EEZ-ON® operation products are defined as energy isolation devices, **NOT AS EMERGENCY STOP DEVICES.**



ROSS EUROPA GmbH
Robert-Bosch-Strasse 2
63225 Langen/Germany
Tel.: +49 6103 7597 0
Fax: +49 6103 74694
e-mail: info@rosseuropa.com
www.rosseuropa.com



ROSS FRANCE S.A.S.
69/73 Boulevard Victor Hugo
Bâtiment 6-8
93400 Saint-Ouen, France
Tel.: +33-1-49456565
Fax: +33-1-49456530
e-mail: sales@rossfrance.com
www.rossfrance.com

ROSS CONTROLS®
1250 Stephenson Hwy.
Troy, Michigan 48083 U.S.A.
Tel.: +1-248-764-1800
Fax: +1-248-764-1850
www.rosscontrols.com

ROSS UK Ltd.
www.rossuk.co.uk

ROSS ASIA K.K.
www.rossasia.co.jp

ROSS SOUTH AMERICA Ltda.
e-mail: vendas@ross-sulamerica.com.br

ROSS CONTROLS (CHINA) Ltd.
www.rosscontrolschina.com

ROSS CONTROLS INDIA Pvt. Ltd.
www.rossindia.com

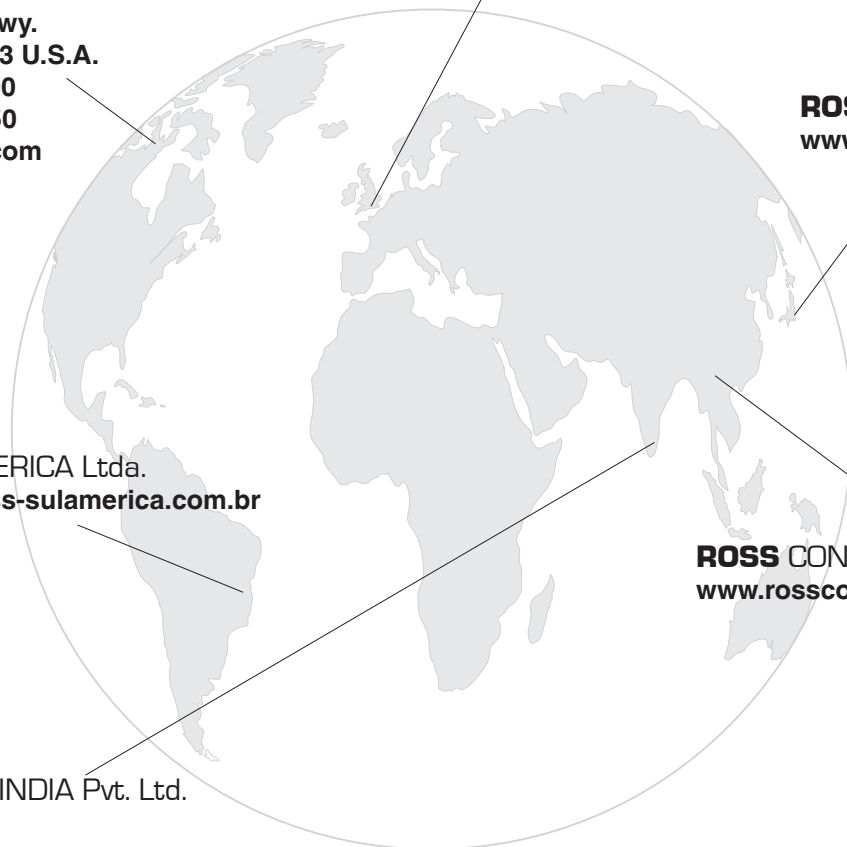

WARRANTY

Products manufactured by ROSS® are warranted to be free of defects in material and workmanship for a period of one year from the date of purchase. ROSS' obligation under this warranty is limited to repair or replacement of the product or refund of the purchase price paid solely at the discretion of ROSS® and provided such product is returned to ROSS® freight prepaid and upon examination by ROSS® is found to be defective. This warranty shall be void in the event that product has been subject to misuse, misapplication, improper maintenance, modification or tampering. The warranty expressed above is in lieu of and exclusive of all other warranties and ROSS® expressly disclaims all other warranties either expressed or implied with respect to merchantability or fitness for a particular purpose. ROSS® makes no warranty with respect to its products meeting the provisions of any governmental occupational safety and/or health laws or regulations. In no event shall ROSS® be liable to purchaser, user, their employees or others for incidental or consequential damages which may result from a breach of the warranty described above or the use or misuse of the products. No statement of any representative or employee of ROSS® shall extend the liability of ROSS® as set forth herein.