



## Product information

### **TE Pump Series**

Submersible pumps

Materials: stainless steel 1.4571

**SCHMITT**

chemical resistant pumps

## Description

### TE Pump Series



**SCHMITT**

chemical resistant pumps

## Submersible pumps

**Application:** The TE Pump Series is particularly suitable if containers or dipping baths cannot be flange connected to the side or if dry run in the plant cannot be excluded as well as for high temperatures.

**Field of application:** Electro-plating technology, airplane jet engine cleaning plants, filtration, large-scale bakeries, räucheranlagen für Wurstherstellung, for very hot alkaline liquids, laboratory applications, Environment engineering, food industry, circulating and mixing tasks, application for dirty and metallically polluted media

**Materials:** stainless steel 1.4571

**Suction head:** 200 - 800 mm

**Max. output rate:** 280 l/min

**Maximale Förderhöhe:** 23 m

**Max. discharge head:** 0,18 - 2,2 kW

In the TE Pump Series, the motor power is transmitted vertically to the pump impeller through an extended shaft. This rotating shaft is exclusively supported through the two motor bearings and therefore runs completely contact free and abrasion-free inside the housing. Due to the construction design, the use of bearing and shaft seals can be forfeited. All parts that are in contact with the medium are made solid of stainless steel (1.4581).

- Advantages:**
- » Application at high temperatures up to +150° C
  - » Absolutely dry run safe (no contact of mechanical parts)
  - » The highest chemical resistance
  - » Robust, thick-walled design, made of only two materials (no thin-walled deep-drawing sheet metal)
  - » Long-lasting and abrasion-free
  - » Design for the operation under demanding conditions
  - » Open impeller (i.e. solids up to 3 mm grain size and 10 Vol. % possible)
  - » No abrasion into the medium to be pumped (high purity applications)
  - » Easy to maintain
  - » Universally applicable, quiet and compact
  - » Available for standardized immersion depths

# Types

## TE Pump Series



**SCHMITT**  
Kreiselpumpen

chemikalienfeste Pumpen

- Materials and Components:**
- » Supporting pipe and shaft made of 1.4571 (A4)
  - » Impeller and housing made of stainless steel fine cast 1.4581 (A4)
  - » Housing gasket made of PTFE
  - » High-quality electric motors made in Germany

- Material details:**
- » **Stainless steel:** 1.4571 or stainless steel fine cast 1.4581 (A4) (up to +150° C)
  - » **PTFE:** virginales Teflon®

### Motor details:

- Standard Motors (stock items):
- » Three-phase motors: 230/400 V 3ph, 50 Hz, IP 55, insulation-class F or 277/480 V 60 Hz also with PTC thermistor
  - » Alternating current motors: 230 V 1ph, 50/60 Hz, IP 55, Insulation class F
- Special design models (available):
- » Three-phase motors, explosion proof, flameproof enclosure, EEx de II CT4
  - » Special voltages and frequencies
  - » 2-, 4- and 8-pole
  - » UL and CSA execution
  - » Special protection types (e.g. IP 65)
  - » High temperature designs
  - » Special insulation classes (e.g. tropical insulations)
  - » Multi area voltage (e.g. 220-290 / 380-500 V 50 Hz; 220-332 / 380-575 V 60 Hz.)
  - » Additional designs upon enquiry.

# Characteristics

## TE Pump Series

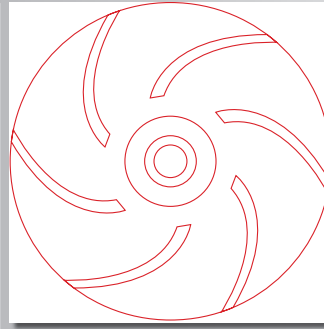

**SCHMITT**  
Kreiselpumpen

chemikalienfeste Pumpen

TE Pump Series	Motor power	ET = depth of immersion
» T 115	0,25 kW	200 - 300 - 400
» T 130	0,55 kW	200 - 300 - 400
» T 150	0,75 kW	300 - 400 - 500
» T 170	1,50 kW	400 - 600 - 800
» T 190	2,20 kW	400 - 600 - 800

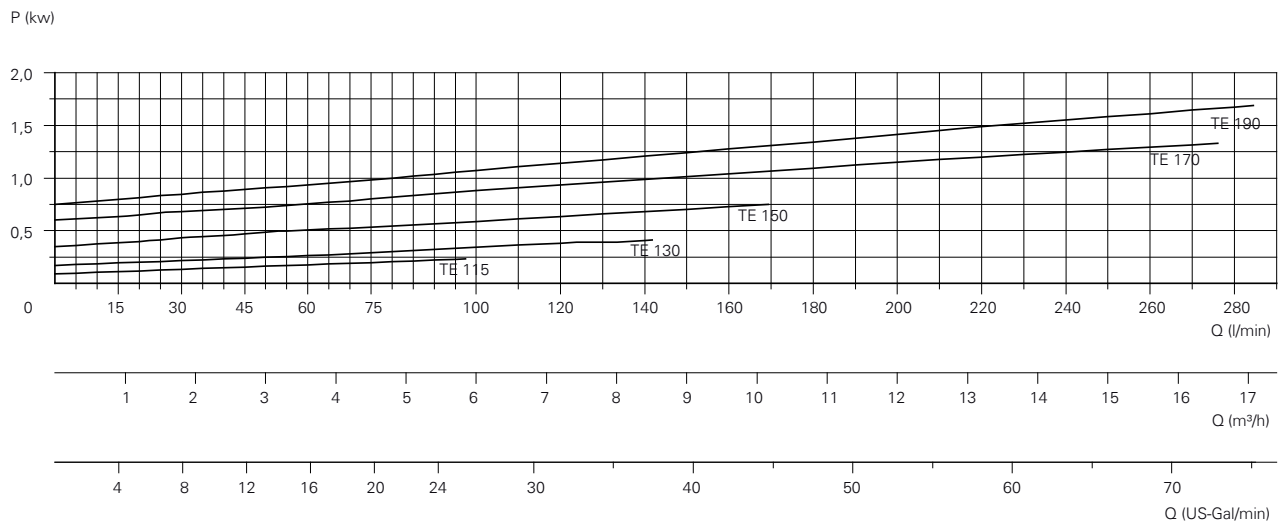
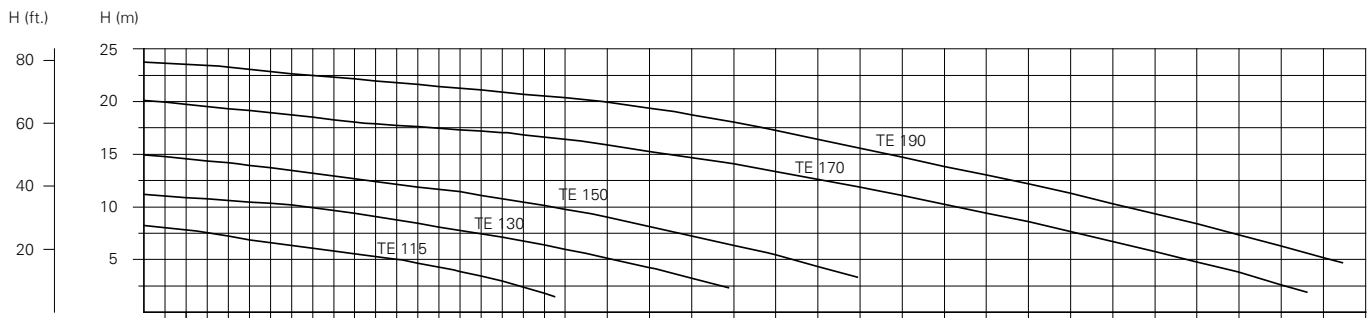

Characteristic lines measured with water, 20° C and 2900 Rpm (50 Hz.)

# Parts Descriptions

## TE Pump series

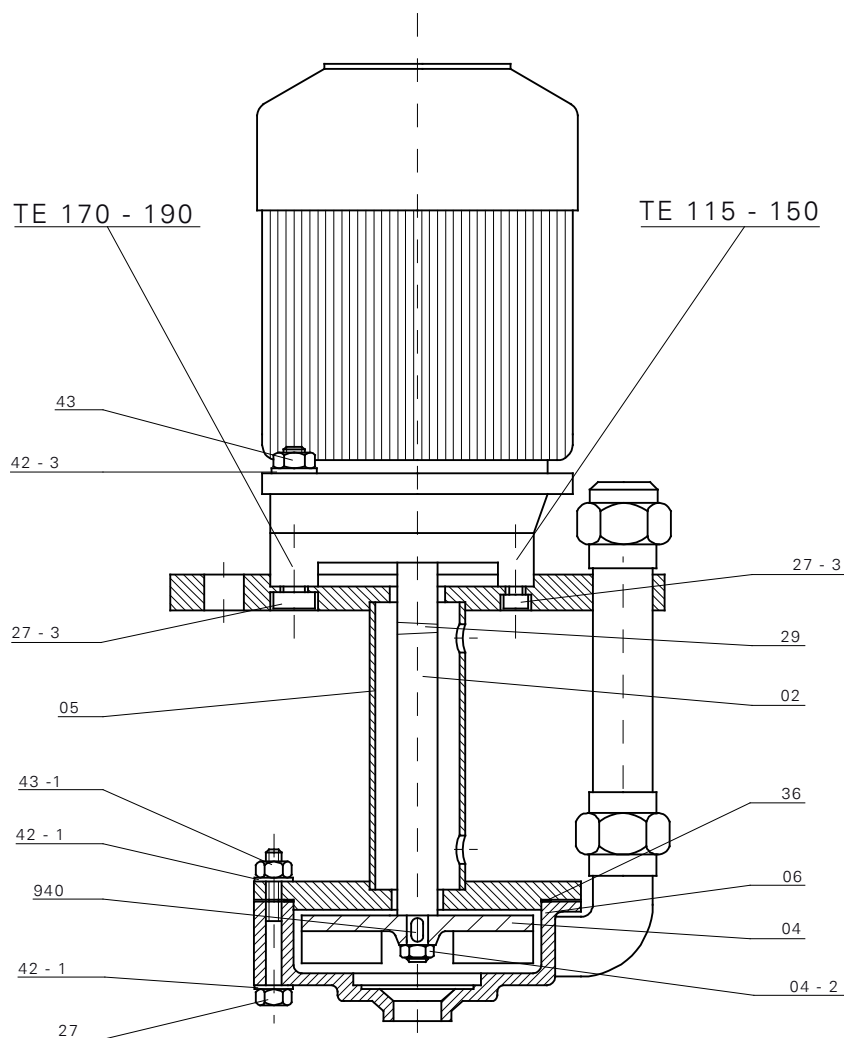

Part-no.	Part	Material
02	shaft	1.4571
04	impeller	1.4581
04-2	counter nut	A4
05	support tube	1.4571
06	pump housing	1.4581
27	bolt	A4
27-3	hexagon bolt	A4
29	cotter pin	A4
36	pump housing seal	PTFE
42-1	washer	A4
42-3	washer	A4
43	hexagon bolt	A4
43-1	hexagon bolt	A4
940	feather key	A4

# Specification

## TE Pump Series

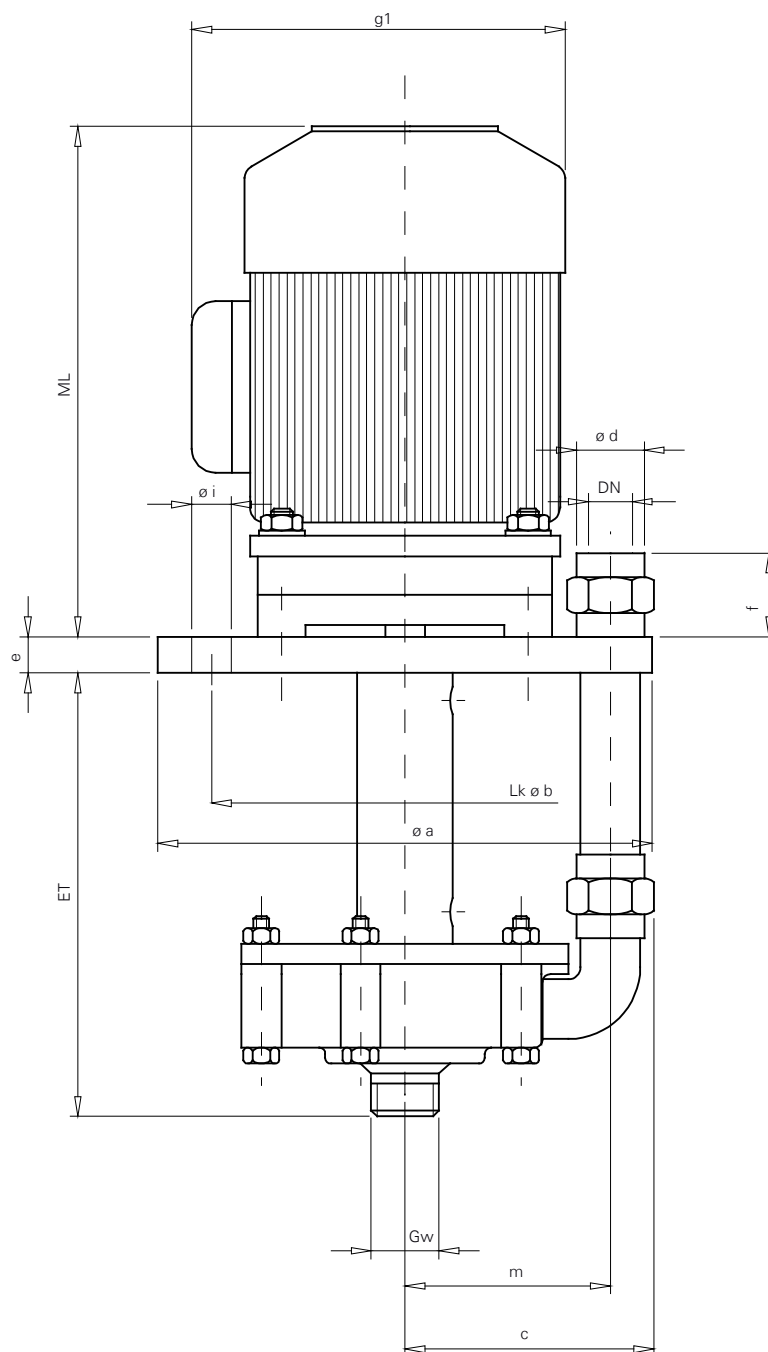

Type	ø a	ø b	c	ø i	e	f	g1	m	ML	ø d	DN
T 115	230	170	121	11	15	44	158	97	211	27	25
T 130	240	200	124	11	15	44	182	100	241	27	25
T 150	265	225	137	11	15	46	209	113	263	27	25
T 170	320	280	156	13	15	50	235	130	278	34	32
T 190	330	280	167	13	15	50	235	141	303	34	32

The dimensions of the motors refer to three-phase standard motors.

## Types TE Pump Series

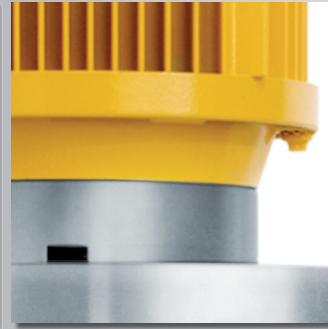

**SCHMITT**  
Kreiselpumpen

chemikalienfeste Pumpen

**Motors:**

- » all driving motors are to IEC standard operating on 230/400 volts 50 cycles.
- » single phase A.C. motors are also available up to 1,10 kW.
- » explosionproof motors can be supplied to the whole range of pumps.
- » special voltages, frequencies and types of protection can be delivered on request.

**Note:**

- » upon request all motors can be supplied for USA standard (UL proof).
- » for each pump also detail handouts are available.

### SCHMITT

Kreiselpumpen GmbH & Co.KG

Einsteinstrasse 33

D - 76275 Ettlingen

fon: +49 - 72 43 - 54 53 - 0

fax: +49 - 72 43 - 54 53 - 22

info@schmitt-pumpen.de

www.schmitt-pumpen.de



We reserve the right to alter the technical details.  
Dimensions and performance details without guarantee.

updated 03/2013