



GLOBE AIRMOTORS B.V.

GLOBE Airmotors | Boerhaaveweg 9-11 | NL - 2408 AD Alphen a/d Rijn | Tel +31 172 426 608 | info@globe-benelux.nl

Specifications: VA1X-NL

Vane Air Motor Non Lubricated

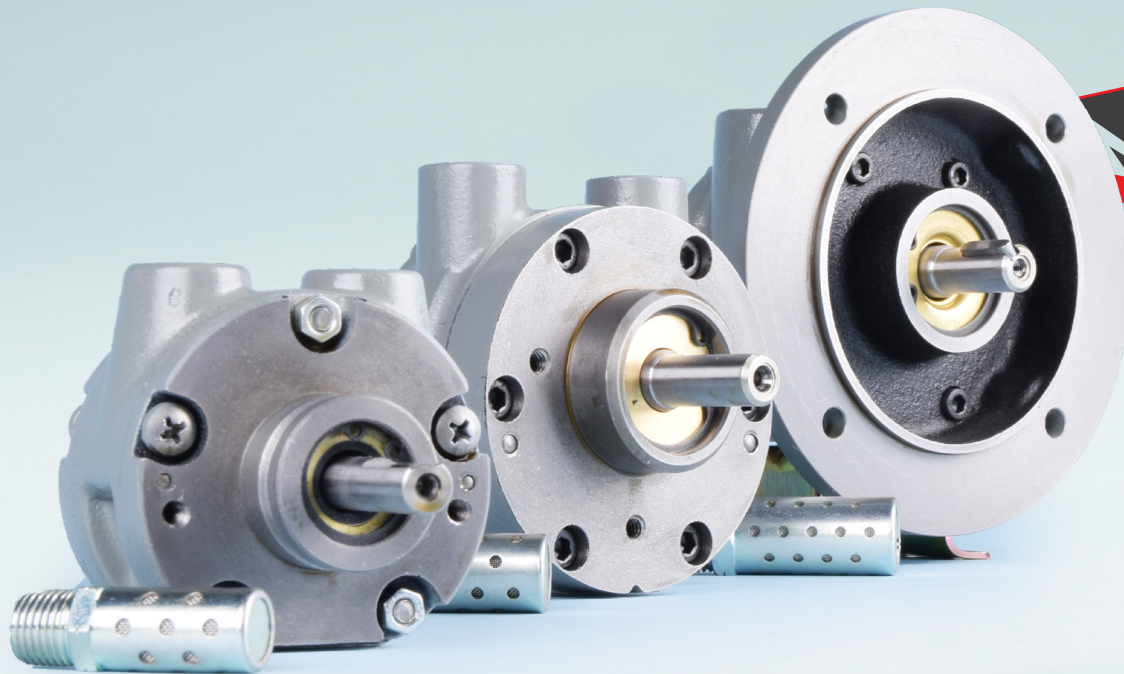

Order your

VANE AIR MOTOR:

info@globe-benelux.nl

Contents

Performance	3
Main dimensions VA1X-NL	3
Accessories for the V1 NL	4

CE  II 2G Ex h IIC T4 Gb
II 2D Ex h IIIC T135°C Db
Ta = - 20° + 60°C

globe-airmotors.com

Ordering Code

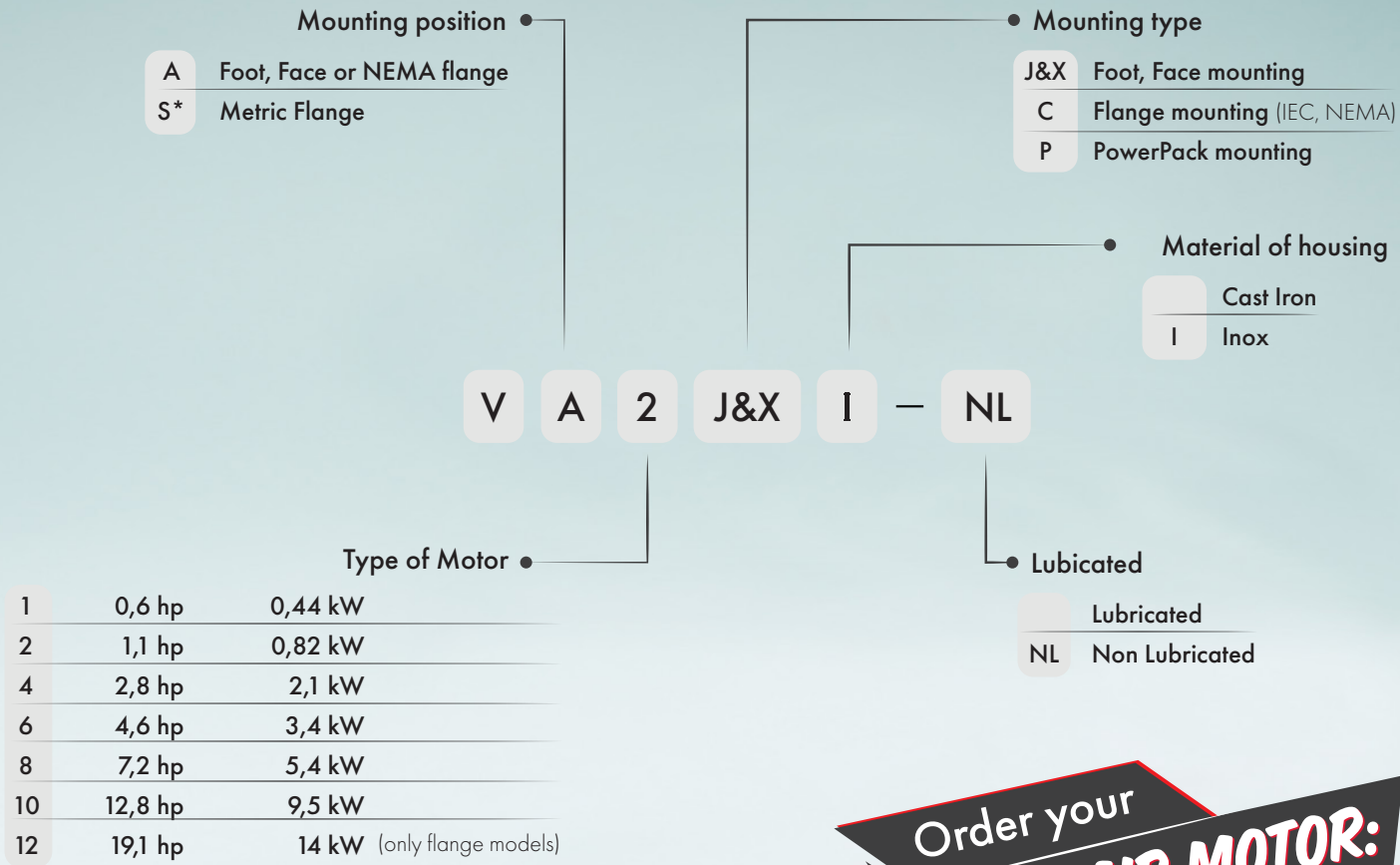

Order your
VANE AIR MOTOR:
orders@globe-benelux.nl

All our Vane Air Motors are delivered with the ATEX Certificate:

II 2G Ex h IIC T4 Gb
II 2D Ex h IIIC T135°C Db
 -20° ≤ Ta ≤ +60°C

* The VS types are only available with mouting type C (for example VS8C).

Performance VA1X-NL

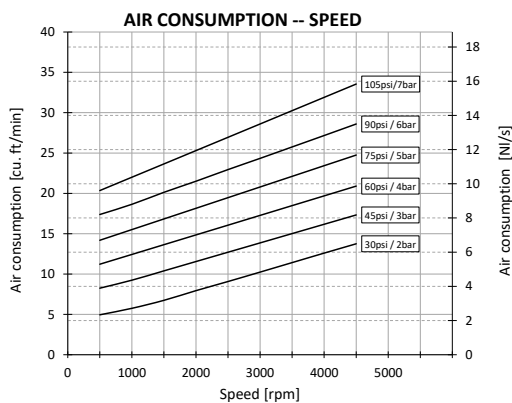
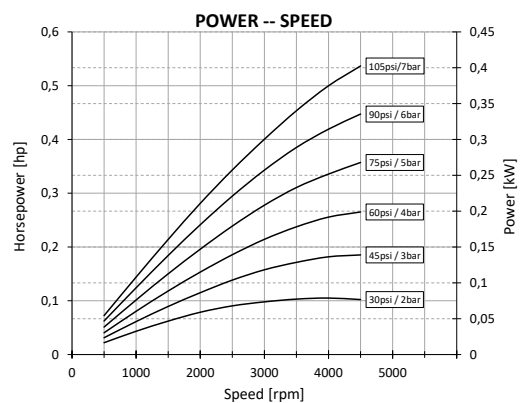
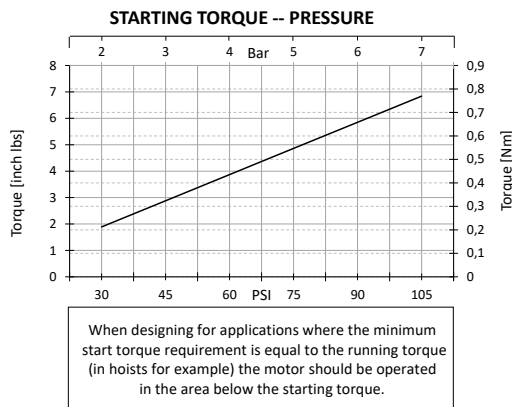
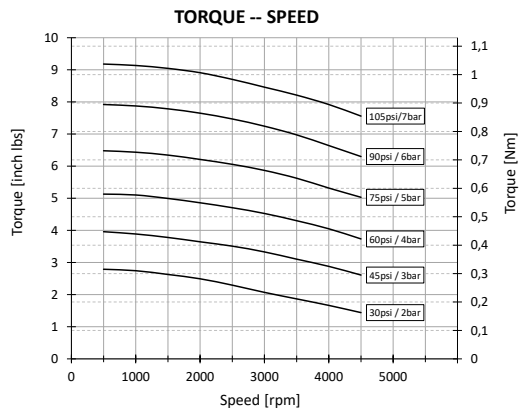

Air quality and filtration:

Use 5 micron filtration. The air has to be dry to prevent corrosion inside the motor when it is not in use. Advisable is to use an air dryer with set point of 20 degrees Celsius below lowest ambient temperature.

- » Silencer supplied with motor.
- » Motor is reversible.
- » Maximum temperature for ATEX applications -20°C to +60°C (-4°F to +140°F)
- » Maximum temperature for non-ATEX applications -20°C to +80°C (-4°F to +176°F)

Maximum speed 4500 rpm | Contineous speed 3000 rpm

Life time depends highly on operational speed and air pressure. Continuous duty is best suited to non lubricated operation. Moisture in the air can cause corrosion problems during rest periods.

Main dimensions VA1X-NL

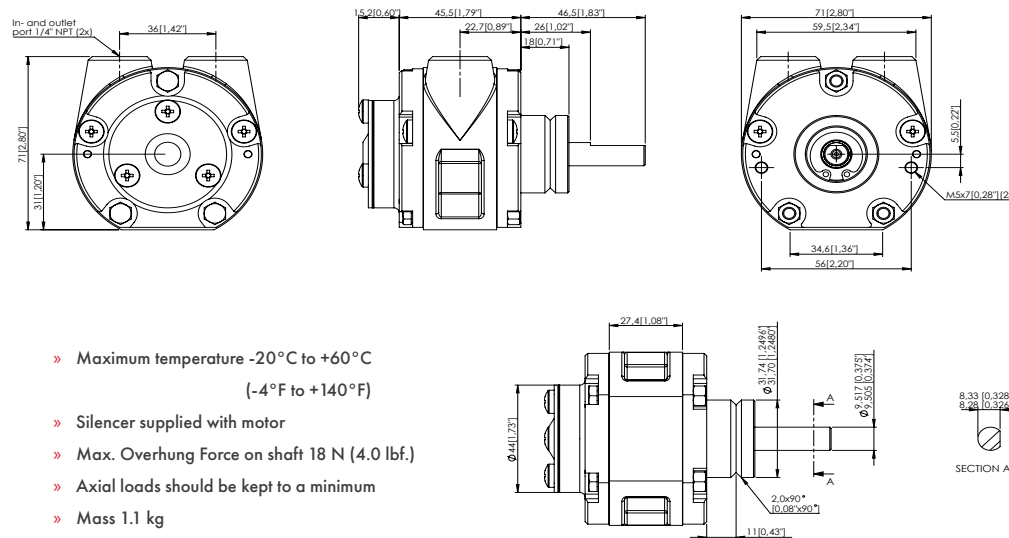

- » Maximum temperature -20°C to +60°C (-4°F to +140°F)
- » Silencer supplied with motor
- » Max. Overhung Force on shaft 18 N (4.0 lbf.)
- » Axial loads should be kept to a minimum
- » Mass 1.1 kg

Note: With air inlet at port 'A', rotation is clockwise looking on shaft. For opposite rotation reverse ports.

Item	Part No.	Description	Qty	Kit No.
1	710-001	Body NPT	1	
2	710-003	Front plate	1	
3	710-002	Back plate	1	
4	-	Gasket	1	719-915
5	710-911	Rotor	1	
6	710-006	Ejection ring	2	
7	-	Rotor blade	4	719-915
8	710-008	Cover plate	1	
9	710-009	Gasket	1	719-915
10	808-065	Shaft seal	1	719-915
13	804-044	Circlip	1	719-915
14	806-009	Dowel pin	4	
15	807-053	Bearing	3	
21	802-700	Screw	3	
23	805-050	Screw	4	
27	801-700	Nut	3	
	719-915	V1NL Service Kit		

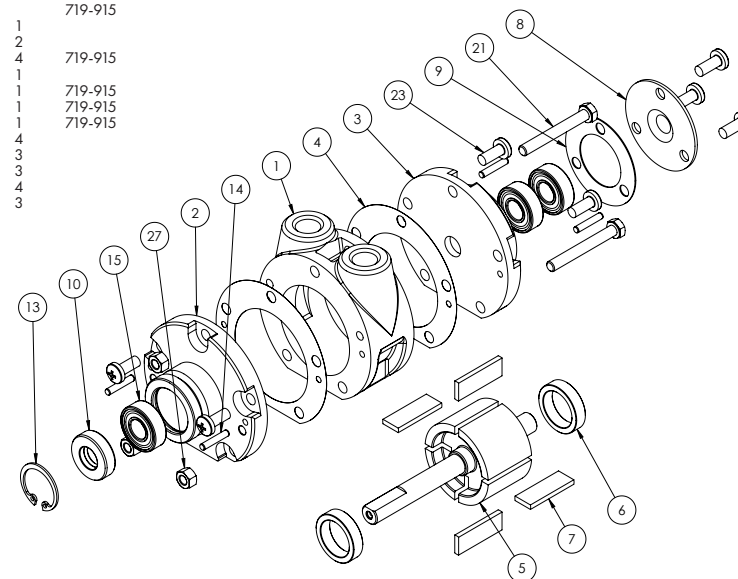

Accessories for the GLOBE Air Motors

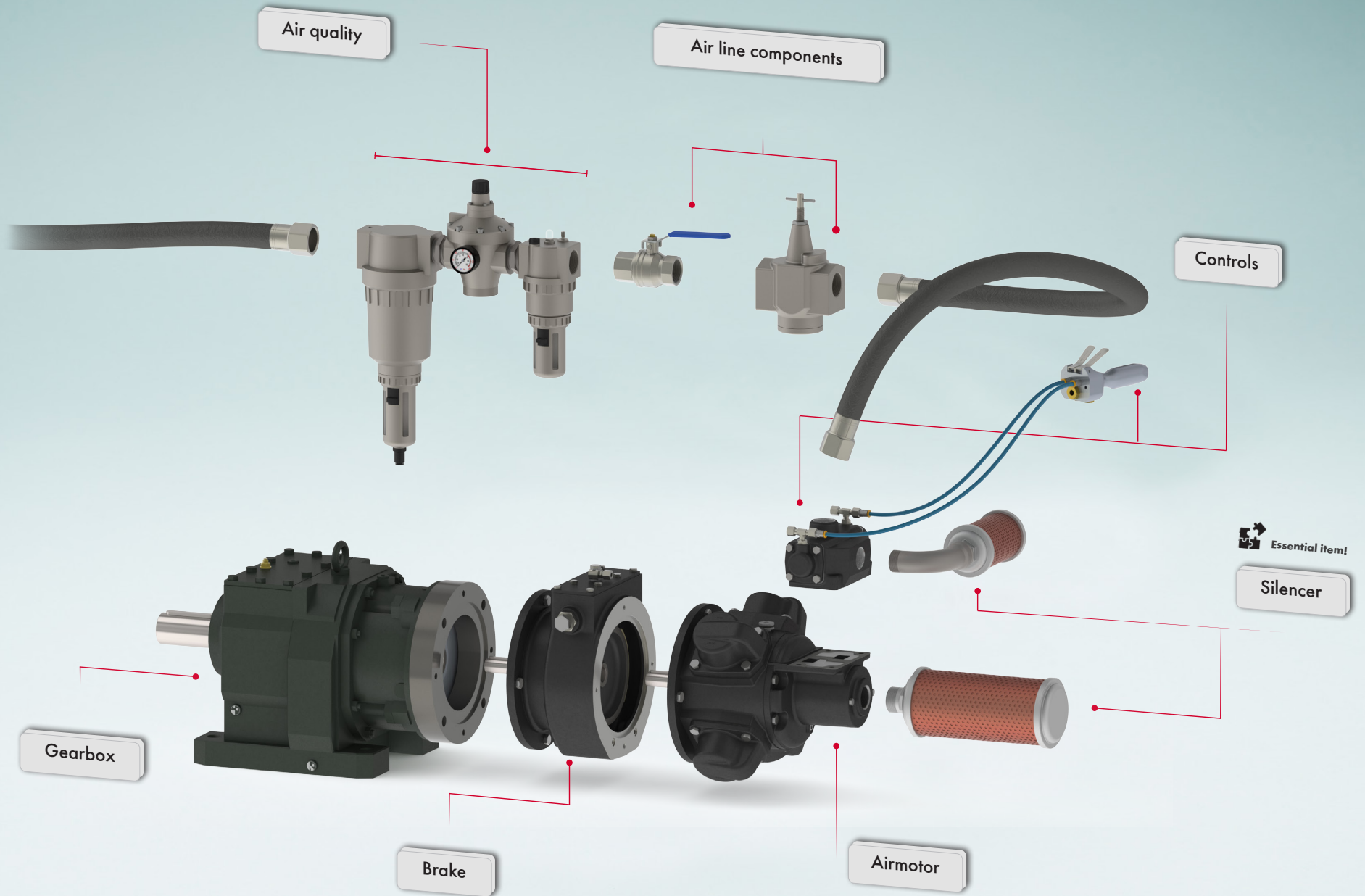

For specifications, see next page.

Accessories for the GLOBE V1 NL Vane Air Motor

Complete your V1 Vane Air Motor with many different accessories. Order your GLOBE air motor with the desired options, and have it delivered to you completely assembled. In addition, you are assured of GLOBE quality for your air motor and assembly.



For
VA1X-NL

Many of our accessories, including the brakes, are ATEX certified. With the GLOBE air motors & accessories you can always work safely in explosion-prone areas. See below which options we offer for your air motor.

Controls

We offer many different control valves for our air motors. For example we supply proportional control valves which are mounted directly onto the air motor. They allow you to not only change the direction of the motor, but also the speed of the motor. Besides the proportional control valves we also offer standard control valves suitable for our air motors.

The following control valves are available for the GLOBE V1 NL Vane Air Motor:

Hand Controlled

ART. NR

Not available

Remote Controlled

ART. NR

Not available

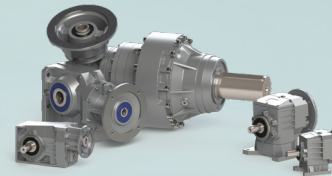

Gearbox

The GLOBE vane air motors are available with worm, coaxial and planetary gearboxes. The gearboxes are mounted directly onto the vane motors. This design makes them compact and well protected from external influences. The gearboxes are compatible with all our vane airmotors, available in stainless steel and with ATEX-Certification.

The following gearboxes are available for the GLOBE V1 NL Vane Air Motor:

Worm

Planetary

Coaxial

PFG

Brakes

The combination of motor with brake is widely used for winches, cranes and positioning devices. The ATEX approved brakes within the GLOBE program have a very compact built and are very robust. All brakes are built from cast iron or steel housings and are easy to install on our air motors and gearboxes.

ART. NR

Not available

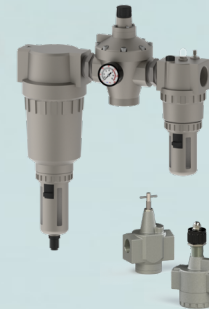

Air quality & Air line components

FRL systems combine a shut off valve, filter, regulator and a lubricator in a ready to use set. It provides you with clean air and an efficient system that will extend the service life of air-powered tools and equipment. By using a speed control valve, you can set your air motor to a desired RPM without reducing its torque. It allows large airflows to pass while minimizing pressure loss at the same time.

3/8" FRL Unit		Speed regulator	
Port size	3/8 inch	Port size	1/4 inch
Max. operating pressure	10 bar / 145 PSI	Port thread	NPT / BSP
Housing material	Aluminium		
Weight	0.75 KG / 1.65 lb		



Essential item!

1/4 " Silencer

An air motor may produce noise that can be harmful to surrounding workers and/or cause noise problems in the application. The GLOBE Pneumatic air silencers are a simple and cost-effective solution to reduce noise levels and unwanted discharge of contaminants.

A GLOBE Silencer is required for optimal reach of maximum power. Choosing a GLOBE Silencer over other brands can prevent loss of power or motor malfunctioning. The GLOBE silencers are designed specifically for our motors.

ART. NR

A31820001

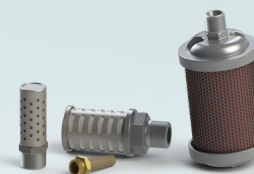

Service Kits

Regular maintenance is important to ensure a long service life of your vane air motor. Our service kits are specifically designed for your vane air motor. One servicekit contains everything you need for a service maintenance. We recommend to always have at least one service kit available in case of unexpected maintenance.

ART. NR

719-915