

Industrial Shock Absorbers

Absorbers to suit – for all loads

ACE industrial shock absorbers work hard. Their application means moving loads are evenly decelerated over the full stroke. The result: the lowest braking force and shortest braking time. The MAGNUM series from ACE is viewed as the reference standard for medium design sizes in damping technology.

Innovations such as diaphragm accumulators, seals, tube-shaped inner pressure chambers and many more make a decisive contribution towards extension of the service life. This means that the effective load range can be extended considerably, which provides users with more scope with respect to the absorber size and utilisation of the machine's output. ACE offers a wide range of matching accessories for this and all other absorber series. This eliminates internal production of assembly parts, which involves high costs and lots of time.

Innovative damping techniques

Reference class for medium sizes

Less stress on the machine

Increase of production figures

Long machine service lives



Industrial Shock Absorbers



MC33 to MC64

Page 50

Self-Compensating

High energy absorption and robust design

Linear slides, Swivel units, Turntables, Portal systems



MC33-V4A to MC64-V4A

Page 54

Self-Compensating, Stainless Steel

Optimum corrosion protection

Linear slides, Swivel units, Turntables, Food industry



MC33-HT to MC64-HT

Page 58

Self-Compensating

Extreme temperatures and high cycle frequencies

Linear slides, Swivel units, Turntables, Machines and plants



MC33-LT to MC64-LT

Page 62

Self-Compensating

Extreme temperatures and high cycle frequencies

Linear slides, Swivel units, Turntables, Machines and plants



SC33 to SC45

Page 66

Self-Compensating, Piston Tube Technology

Piston tube design for maximum energy absorption

Turntables, Swivel units, Robot arms, Linear slides



MA/ML33 to MA/ML64

Page 70

Adjustable

High energy absorption and progressive adjustment

Linear slides, Swivel units, Turntables, Portal systems

MC33 to MC64 Industrial Shock Absorbers

High energy absorption and robust design

The latest damper technology: The combination of the latest sealing technology, annealed guide bearing and integrated positiv stop make these self-compensating shock absorbers from ACE'S MAGNUM range so successful. After all, users benefit from the longer service life of the products, even in the most difficult environments. A continuous outer thread and extensive accessories make their contribution to the success story of the MC33 to MC64.

High energy absorption in a compact design and a wide damping range lead to huge advantages in practice. Alongside generally more compact designs, these small yet very powerful absorbers enable full use of the machine's performance.

These self-compensating industrial shock absorbers are used in all areas of mechanical engineering – especially in automation and for gantries.

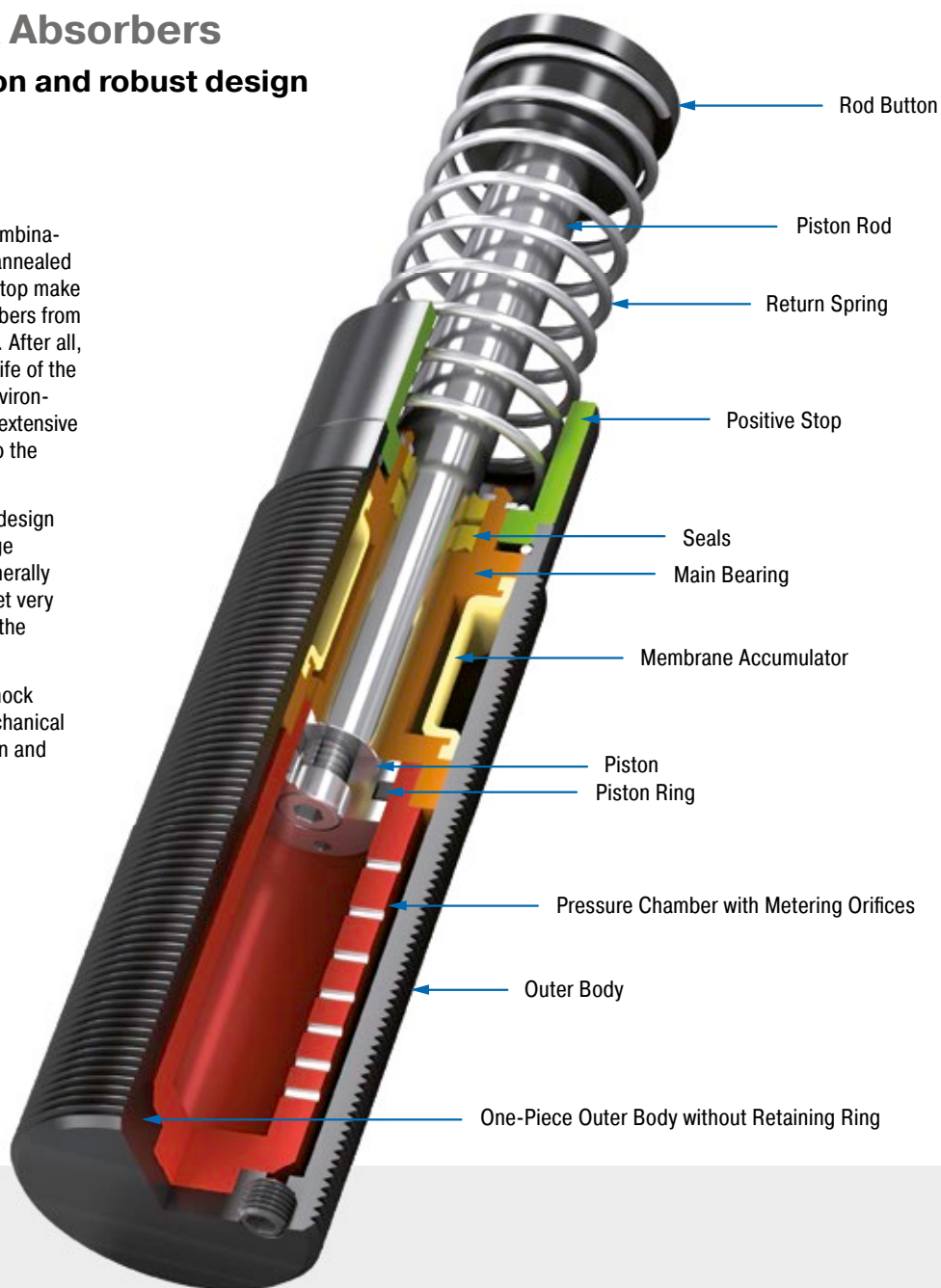

Technical Data

Energy capacity: 155 Nm/Cycle to 5,100 Nm/Cycle

Impact velocity range: 0.15 m/s to 5 m/s.
Other speeds on request.

Operating temperature range: -12 °C to +66 °C. Other temperatures on request.

Mounting: In any position

Positive stop: Integrated

Material: Outer body: Nitride hardened steel; Piston rod: Hard chrome plated steel; Rod end button: Hardened steel and corrosion-resistant coating; Return spring: Zinc plated or

plastic-coated steel; Accessories: Steel with black oxide finish or nitride hardened

Damping medium: Automatic Transmission Fluid (ATF)

Application field: Linear slides, Swivel units, Turntables, Portal systems

Note: A noise reduction of 3 to 7 dB is possible when using the special impact button (PP). For emergency use only applications and for continuous use (with additional cooling) it is sometimes possible to exceed the published max. capacity ratings. In this case, please consult ACE.

Safety instructions: External materials in the surrounding area can attack the seal components and lead to a shorter service life. Please contact ACE for appropriate solution suggestions. Do not paint the shock absorbers due to heat emission.

On request: Special oils, nickel-plated, increased corrosion protection, mounting inside air cylinders or other special options are available on request.

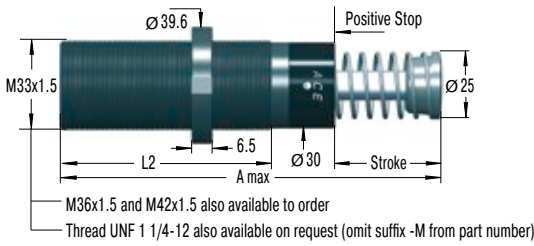
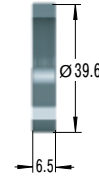
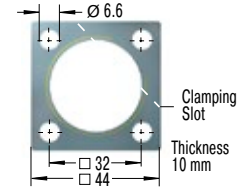
MC33EUM

NM33
Locking Ring

QF33
Square Flange

Torque max.: 11 Nm
Clamping torque: > 90 Nm
Install with 4 machine screws

The calculation and selection of the most suitable damper should be carried out or be approved by ACE.

Model Type Prefix
Standard Models

MC: Self-Contained with return spring, self-compensating

Special Models

MCA: Air/Oil return without return spring.

Use only with external air/oil tank.

MCS: Air/Oil return with return spring.

Use only with external air/oil tank.

MCN: Self-Contained without return spring

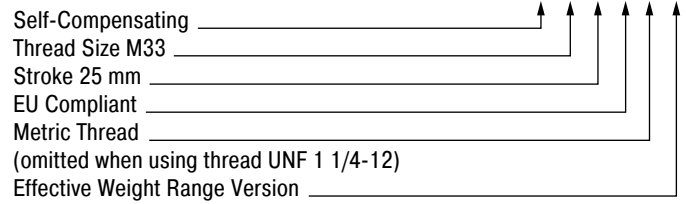
Ordering Example
MC3325EUM-1

Dimensions

TYPES	Stroke mm	A max. mm	L2 mm
MC3325EUM	23.2	138	83
MC3350EUM	48.6	189	108

Performance

TYPES	Max. Energy Capacity				Effective Weight			Return force min. N	Return force max. N	Return time s	Side Load Angle max. °	Weight kg
	¹ W ₃ Nm/cycle	W ₄ Nm/h	W ₄ with Air/ Oil Tank Nm/h	W ₄ with Oil Recirculation Nm/h	² me min. kg	² me max. kg	Hardness					
MC3325EUM-0	155	75,000	124,000	169,000	3	11	-0	45	90	0.03	4	0.45
MC3325EUM-1	155	75,000	124,000	169,000	9	40	-1	45	90	0.03	4	0.45
MC3325EUM-2	155	75,000	124,000	169,000	30	120	-2	45	90	0.03	4	0.45
MC3325EUM-3	155	75,000	124,000	169,000	100	420	-3	45	90	0.03	4	0.45
MC3325EUM-4	155	75,000	124,000	169,000	350	1,420	-4	45	90	0.03	4	0.45
MC3350EUM-0	310	85,000	135,000	180,000	5	22	-0	45	135	0.06	3	0.54
MC3350EUM-1	310	85,000	135,000	180,000	18	70	-1	45	135	0.06	3	0.54
MC3350EUM-2	310	85,000	135,000	180,000	60	250	-2	45	135	0.06	3	0.54
MC3350EUM-3	310	85,000	135,000	180,000	210	840	-3	45	135	0.06	3	0.54
MC3350EUM-4	310	85,000	135,000	180,000	710	2,830	-4	45	135	0.06	3	0.54

¹ For emergency use only applications it is sometimes possible to exceed the above ratings. Please consult ACE for further details.

² The effective weight range limits can be raised or lowered to special order.

³ For applications with higher side load angles consider using the side load adaptor (BV) pages 74 to 77.

Self-Compensating

MC45EUM

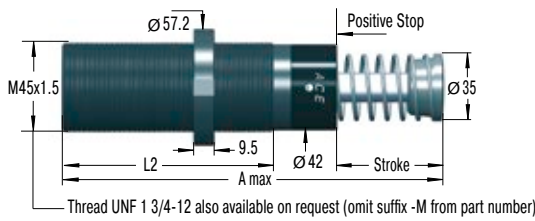

NM45 Locking Ring

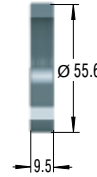

QF45 Square Flange

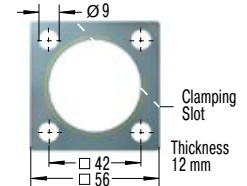

Torque max.: 27 Nm
Clamping torque: > 200 Nm
Install with 4 machine screws

The calculation and selection of the most suitable damper should be carried out or be approved by ACE.

Model Type Prefix

Standard Models

MC: Self-Contained with return spring, self-compensating

Special Models

MCA: Air/Oil return without return spring.

Use only with external air/oil tank.

MCS: Air/Oil return with return spring.

Use only with external air/oil tank.

MCN: Self-Contained without return spring

Ordering Example

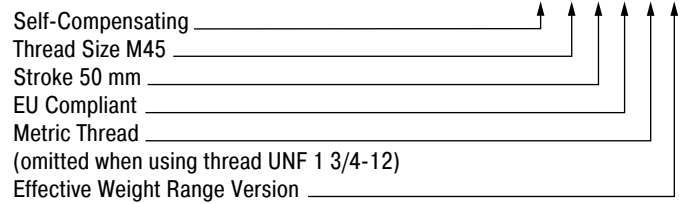

Dimensions

TYPES	Stroke mm	A max. mm	L2 mm
MC4525EUM	23.1	145	95
MC4550EUM	48.5	195	120
MC4575EUM	73.9	246	145

Performance

TYPES	Max. Energy Capacity				Effective Weight			Return force min. N	Return force max. N	Return time s	Side Load Angle max. °	Weight kg
	¹ W ₃ Nm/cycle	W ₄ Nm/h	W ₄ with Air/ Oil Tank Nm/h	W ₄ with Oil Recirculation Nm/h	² me min. kg	² me max. kg	Hardness					
MC4525EUM-0	340	107,000	158,000	192,000	7	27	-0	70	100	0.03	4	1.13
MC4525EUM-1	340	107,000	158,000	192,000	20	90	-1	70	100	0.03	4	1.13
MC4525EUM-2	340	107,000	158,000	192,000	80	310	-2	70	100	0.03	4	1.13
MC4525EUM-3	340	107,000	158,000	192,000	260	1,050	-3	70	100	0.03	4	1.13
MC4525EUM-4	340	107,000	158,000	192,000	890	3,540	-4	70	100	0.03	4	1.13
MC4550EUM-0	680	112,000	192,000	248,000	13	54	-0	70	145	0.08	3	1.36
MC4550EUM-1	680	112,000	192,000	248,000	45	180	-1	70	145	0.08	3	1.36
MC4550EUM-2	680	112,000	192,000	248,000	150	620	-2	70	145	0.08	3	1.36
MC4550EUM-3	680	112,000	192,000	248,000	520	2,090	-3	70	145	0.08	3	1.36
MC4550EUM-4	680	112,000	192,000	248,000	1,800	7,100	-4	70	145	0.08	3	1.36
MC4575EUM-0	1,020	146,000	225,000	282,000	20	80	-0	50	180	0.11	2	1.59
MC4575EUM-1	1,020	146,000	225,000	282,000	70	270	-1	50	180	0.11	2	1.59
MC4575EUM-2	1,020	146,000	225,000	282,000	230	930	-2	50	180	0.11	2	1.59
MC4575EUM-3	1,020	146,000	225,000	282,000	790	3,140	-3	50	180	0.11	2	1.59
MC4575EUM-4	1,020	146,000	225,000	282,000	2,650	10,600	-4	50	180	0.11	2	1.59

¹ For emergency use only applications it is sometimes possible to exceed the above ratings. Please consult ACE for further details.

² The effective weight range limits can be raised or lowered to special order.

³ For applications with higher side load angles consider using the side load adaptor (BV) pages 74 to 77.

Self-Compensating

MC64EUM

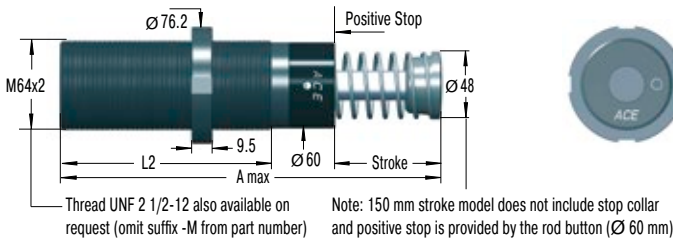

NM64 Locking Ring

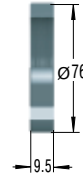

QF64 Quadratflansch

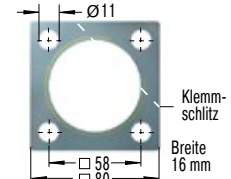

Torque max.: 50 Nm
Clamping torque: > 210 Nm
Install with 4 machine screws

The calculation and selection of the most suitable damper should be carried out or be approved by ACE.

Model Type Prefix

Standard Models

MC: Self-Contained with return spring, self-compensating

Special Models

MCA: Air/Oil return without return spring.

Use only with external air/oil tank.

MCS: Air/Oil return with return spring.

Use only with external air/oil tank.

MCN: Self-Contained without return spring

Ordering Example

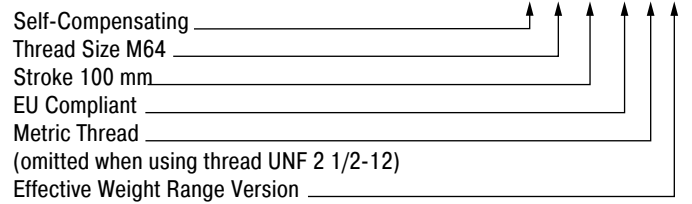

Dimensions

TYPES	Stroke mm	A max. mm	L2 mm
MC6450EUM	48.6	225	140
MC64100EUM	99.4	326	191
MC64150EUM	150	450	241

Performance

TYPES	Max. Energy Capacity				Effective Weight			Return force min. N	Return force max. N	Return time s	Side Load Angle max. °	Weight kg
	¹ W ₃ Nm/cycle	W ₄ Nm/h	W ₄ with Air/ Oil Tank Nm/h	W ₄ with Oil Recirculation Nm/h	² me min. kg	² me max. kg	Hardness					
MC6450EUM-0	1,700	146,000	293,000	384,000	35	140	-0	90	155	0.12	4	2.9
MC6450EUM-1	1,700	146,000	293,000	384,000	140	540	-1	90	155	0.12	4	2.9
MC6450EUM-2	1,700	146,000	293,000	384,000	460	1,850	-2	90	155	0.12	4	2.9
MC6450EUM-3	1,700	146,000	293,000	384,000	1,600	6,300	-3	90	155	0.12	4	2.9
MC6450EUM-4	1,700	146,000	293,000	384,000	5,300	21,200	-4	90	155	0.12	4	2.9
MC64100EUM-0	3,400	192,000	384,000	497,000	70	280	-0	105	270	0.34	3	3.7
MC64100EUM-1	3,400	192,000	384,000	497,000	270	1,100	-1	105	270	0.34	3	3.7
MC64100EUM-2	3,400	192,000	384,000	497,000	930	3,700	-2	105	270	0.34	3	3.7
MC64100EUM-3	3,400	192,000	384,000	497,000	3,150	12,600	-3	105	270	0.34	3	3.7
MC64100EUM-4	3,400	192,000	384,000	497,000	10,600	42,500	-4	105	270	0.34	3	3.7
MC64150EUM-0	5,100	248,000	497,000	644,000	100	460	-0	75	365	0.48	2	5.1
MC64150EUM-1	5,100	248,000	497,000	644,000	410	1,640	-1	75	365	0.48	2	5.1
MC64150EUM-2	5,100	248,000	497,000	644,000	1,390	5,600	-2	75	365	0.48	2	5.1
MC64150EUM-3	5,100	248,000	497,000	644,000	4,700	18,800	-3	75	365	0.48	2	5.1
MC64150EUM-4	5,100	248,000	497,000	644,000	16,000	63,700	-4	75	365	0.48	2	5.1

¹ For emergency use only applications it is sometimes possible to exceed the above ratings. Please consult ACE for further details.

² The effective weight range limits can be raised or lowered to special order.

³ For applications with higher side load angles consider using the side load adaptor (BV) pages 74 to 77.

MC33-V4A to MC64-V4A

Industrial Shock Absorbers

Optimum corrosion protection

The latest damper technology in stainless steel: The self-compensating industrial shock absorbers MC33 to MC64 from the tried-and-tested and popular MAGNUM series is also available with all outer components made from stainless steel (material 1.4404). They are filled in the factory with special oil, which meets the permit conditions (NSF-H1) for the food industry.

Just like the standard product family, the MAGNUM stainless steel models are distinguished by their robust, modern sealing technology, high energy absorption in a compact design, integrated positive stop and a wide damping range. Equipped with a PU head, they are available in thread sizes M33x1.5 to M64x2 with damping strokes up to 100 mm.

These self-compensating industrial shock absorbers made of stainless steel from ACE are mainly used in the food, medical, electro and offshore industries, but also in many other markets.

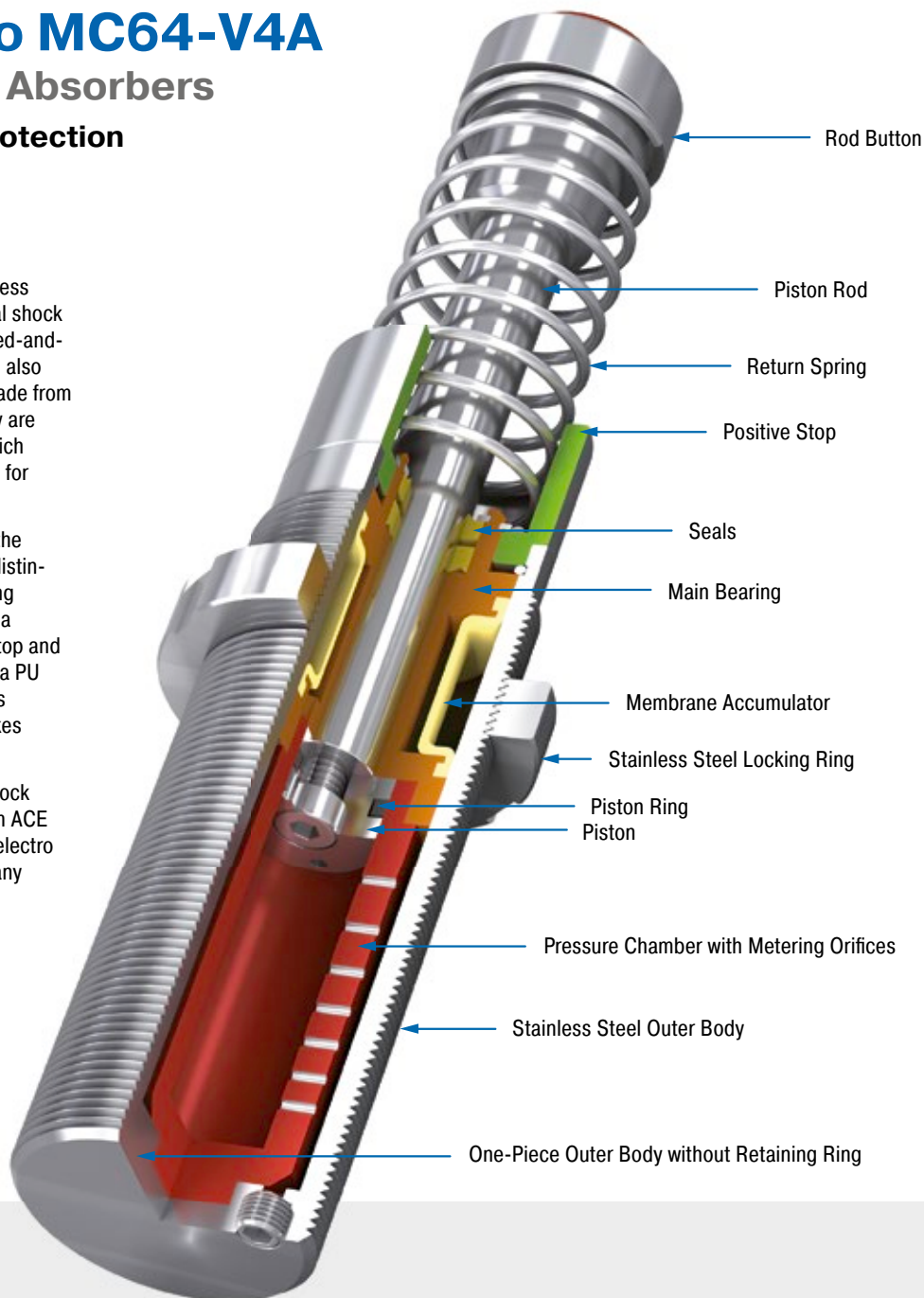

Technical Data

Energy capacity: 155 Nm/Cycle to 5,100 Nm/Cycle

Impact velocity range: 0.15 m/s to 5 m/s. Other speeds on request.

Operating temperature range: -12 °C to +66 °C. Other temperatures on request.

Mounting: In any position

Positive stop: Integrated

Material: Outer body, Main bearing, Accessories, Locking ring: Stainless steel (1.4404, AISI 316L); Piston rod: Hard chrome plated steel; Rod end button: Stainless steel

(1.4404, AISI 316L) with elastomer insert; Return spring: Stainless steel

Damping medium: Special oil NSF-H1 approved

Application field: Linear slides, Swivel units, Turntables, Food industry

Note: Impact button (PP) for noise reduction included. For emergency use only applications and for continuous use (with additional cooling) it is sometimes possible to exceed the published max. capacity ratings. In this case, please consult ACE.

Safety instructions: External materials in the surrounding area can attack the seal components and lead to a shorter service life. Please contact ACE for appropriate solution suggestions. Do not paint the shock absorbers due to heat emission.

On request: Special oils, other special options and special accessories are available on request.

MC33EUM-V4A

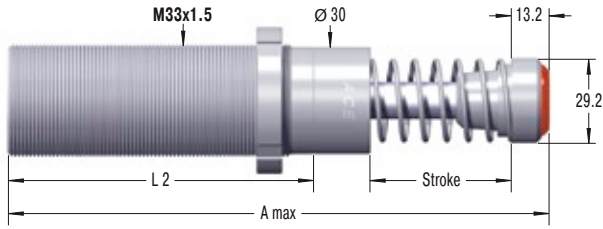

NM33-V4A Locking Ring

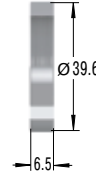

QF33-V4A Quadratflansch

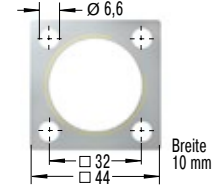

The calculation and selection of the most suitable damper should be carried out or be approved by ACE.

Model Type Prefix

Standard Models

MC: Self-Contained with return spring, self-compensating

Special Models

MCA: Air/Oil return without return spring.

Use only with external air/oil tank.

MCS: Air/Oil return with return spring.

Use only with external air/oil tank.

MCN: Self-Contained without return spring

Ordering Example

MC3325EUM-2-V4A

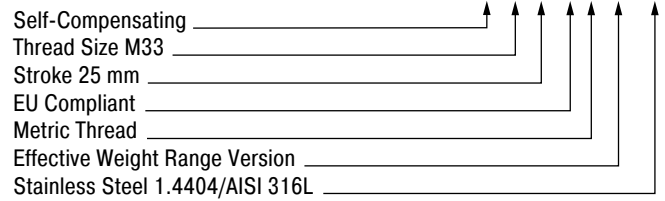

Performance and Dimensions

TYPES	Max. Energy Capacity		Effective Weight			Stroke mm	A max. mm	L2 mm	Return force		Return time s	Side Load		Weight kg
	W ₃ Nm/cycle	W ₄ Nm/h	¹ me min. kg	¹ me max. kg	Hardness				min. N	max. N		Angle max. °		
MC3325EUM-0-V4A	155	75,000	3	11	-0	23.2	151.2	83	45	90	0.03	4	0.45	
MC3325EUM-1-V4A	155	75,000	9	40	-1	23.2	151.2	83	45	90	0.03	4	0.45	
MC3325EUM-2-V4A	155	75,000	30	120	-2	23.2	151.2	83	45	90	0.03	4	0.45	
MC3325EUM-3-V4A	155	75,000	100	420	-3	23.2	151.2	83	45	90	0.03	4	0.45	
MC3325EUM-4-V4A	155	75,000	350	1,420	-4	23.2	151.2	83	45	90	0.03	4	0.45	
MC3350EUM-0-V4A	310	85,000	5	22	-0	48.6	202.2	108	45	135	0.06	3	0.54	
MC3350EUM-1-V4A	310	85,000	18	70	-1	48.6	202.2	108	45	135	0.06	3	0.54	
MC3350EUM-2-V4A	310	85,000	60	250	-2	48.6	202.2	108	45	135	0.06	3	0.54	
MC3350EUM-3-V4A	310	85,000	210	840	-3	48.6	202.2	108	45	135	0.06	3	0.54	
MC3350EUM-4-V4A	310	85,000	710	2,830	-4	48.6	202.2	108	45	135	0.06	3	0.54	

¹ For emergency use only applications it is sometimes possible to exceed the above ratings. Please consult ACE for further details.

² For applications with higher side load angles consider using the side load adaptor (BV) pages 74 to 77.

MC45EUM-V4A

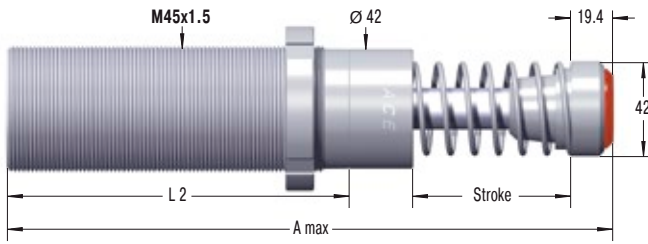

NM45-V4A
Locking Ring

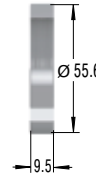

QF45-V4A
Square Flange

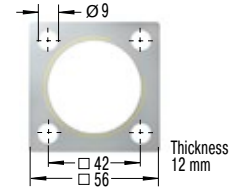

The calculation and selection of the most suitable damper should be carried out or be approved by ACE.

Model Type Prefix

Standard Models

MC: Self-Contained with return spring, self-compensating

Special Models

MCA: Air/Oil return without return spring.

Use only with external air/oil tank.

MCS: Air/Oil return with return spring.

Use only with external air/oil tank.

MCN: Self-Contained without return spring

Ordering Example

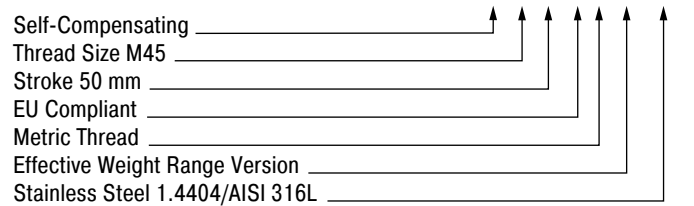

Performance and Dimensions

TYPES	Max. Energy Capacity		Effective Weight			Stroke mm	A max. mm	L2 mm	Return force		Return time s	Side Load		Weight kg
	W ₃ Nm/cycle	W ₁ Nm/h	¹ me min. kg	¹ me max. kg	Hardness				min. N	max. N		Angle max. °		
MC4525EUM-0-V4A	340	107,000	7	27	-0	23.1	164.5	95	70	100	0.03	4	1.13	
MC4525EUM-1-V4A	340	107,000	20	90	-1	23.1	164.5	95	70	100	0.03	4	1.13	
MC4525EUM-2-V4A	340	107,000	80	310	-2	23.1	164.5	95	70	100	0.03	4	1.13	
MC4525EUM-3-V4A	340	107,000	260	1,050	-3	23.1	164.5	95	70	100	0.03	4	1.13	
MC4525EUM-4-V4A	340	107,000	890	3,540	-4	23.1	164.5	95	70	100	0.03	4	1.13	
MC4550EUM-0-V4A	680	112,000	13	54	-0	48.5	214.4	120	70	145	0.08	3	1.36	
MC4550EUM-1-V4A	680	112,000	45	180	-1	48.5	214.4	120	70	145	0.08	3	1.36	
MC4550EUM-2-V4A	680	112,000	150	620	-2	48.5	214.4	120	70	145	0.08	3	1.36	
MC4550EUM-3-V4A	680	112,000	520	2,090	-3	48.5	214.4	120	70	145	0.08	3	1.36	
MC4550EUM-4-V4A	680	112,000	1,800	7,100	-4	48.5	214.4	120	70	145	0.08	3	1.36	
MC4575EUM-0-V4A	1,020	146,000	20	80	-0	73.9	265.4	145	50	180	0.11	2	1.59	
MC4575EUM-1-V4A	1,020	146,000	70	270	-1	73.9	265.4	145	50	180	0.11	2	1.59	
MC4575EUM-2-V4A	1,020	146,000	230	930	-2	73.9	265.4	145	50	180	0.11	2	1.59	
MC4575EUM-3-V4A	1,020	146,000	790	3,140	-3	73.9	265.4	145	50	180	0.11	2	1.59	
MC4575EUM-4-V4A	1,020	146,000	2,650	10,600	-4	73.9	265.4	145	50	180	0.11	2	1.59	

¹ For emergency use only applications it is sometimes possible to exceed the above ratings. Please consult ACE for further details.
² For applications with higher side load angles consider using the side load adaptor (BV) pages 74 to 77.

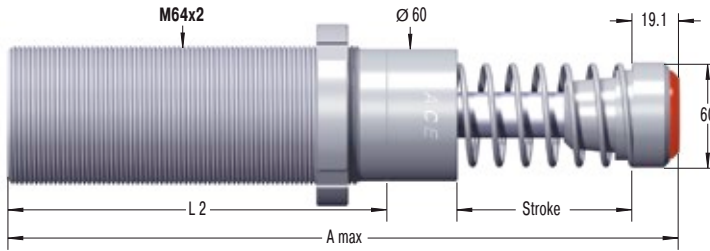
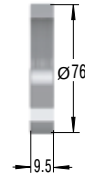
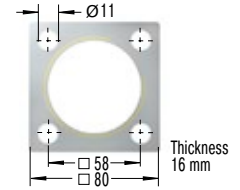
MC64EUM-V4A

NM64-V4A
Locking Ring

QF64-V4A
Square Flange

The calculation and selection of the most suitable damper should be carried out or be approved by ACE.

Model Type Prefix
Standard Models

MC: Self-Contained with return spring, self-compensating

Special Models

MCA: Air/Oil return without return spring.

Use only with external air/oil tank.

MCS: Air/Oil return with return spring.

Use only with external air/oil tank.

MCN: Self-Contained without return spring

Ordering Example
MC6450EUM-3-V4A

Self-Compensating _____ ↑
 Thread Size M64 _____ ↑
 Stroke 50 mm _____ ↑
 EU Compliant _____ ↑
 Metric Thread _____ ↑
 Effective Weight Range Version _____ ↑
 Stainless Steel 1.4404/AISI 316L _____ ↑

Performance and Dimensions

TYPES	Max. Energy Capacity		Effective Weight			Stroke mm	A max. mm	L2 mm	Return force		Return time s	Side Load		Weight kg
	W ₃ Nm/cycle	W ₄ Nm/h	¹ me min. kg	¹ me max. kg	Hardness				min. N	max. N		Angle max. °		
MC6450EUM-0-V4A	1,700	146,000	35	140	-0	48.6	244.1	140	90	155	0.12	4	2.9	
MC6450EUM-1-V4A	1,700	146,000	140	540	-1	48.6	244.1	140	90	155	0.12	4	2.9	
MC6450EUM-2-V4A	1,700	146,000	460	1,850	-2	48.6	244.1	140	90	155	0.12	4	2.9	
MC6450EUM-3-V4A	1,700	146,000	1,600	6,300	-3	48.6	244.1	140	90	155	0.12	4	2.9	
MC6450EUM-4-V4A	1,700	146,000	5,300	21,200	-4	48.6	244.1	140	90	155	0.12	4	2.9	
MC64100EUM-0-V4A	3,400	192,000	70	280	-0	99.4	345.1	191	105	270	0.34	3	3.7	
MC64100EUM-1-V4A	3,400	192,000	270	11,000	-1	99.4	345.1	191	105	270	0.34	3	3.7	
MC64100EUM-2-V4A	3,400	192,000	930	3,700	-2	99.4	345.1	191	105	270	0.34	3	3.7	
MC64100EUM-3-V4A	3,400	192,000	3,150	12,600	-3	99.4	345.1	191	105	270	0.34	3	3.7	
MC64100EUM-4-V4A	3,400	192,000	10,600	42,500	-4	99.4	345.1	191	105	270	0.34	3	3.7	

¹ For emergency use only applications it is sometimes possible to exceed the above ratings. Please consult ACE for further details.

² For applications with higher side load angles consider using the side load adaptor (BV) pages 74 to 77.

MC33-HT to MC64-HT

Industrial Shock Absorbers

Extreme temperatures and high cycle frequencies

Further possibilities of use: Just like all MAGNUM types from the product family MC33 to MC64, the HT (high temperature) industrial shock absorbers are also made from one solid piece. They are characterised by the use of special seals and fluids. This means that these versions can even be used at extreme temperatures of 0 °C to 150 °C in order to safely and reliably damp masses and take away 100 % kinetic energy.

There is no reason why these ready-to-install machine elements should not be used, even under the most unfavourable conditions. Additional benefits are their robust, innovative sealing technology, high energy absorption in a compact design, fixed positive stop and a wide damping range.

Designed for use in extreme temperature ranges, these self-compensating industrial shock absorbers are suitable almost anywhere in plant and mechanical engineering.

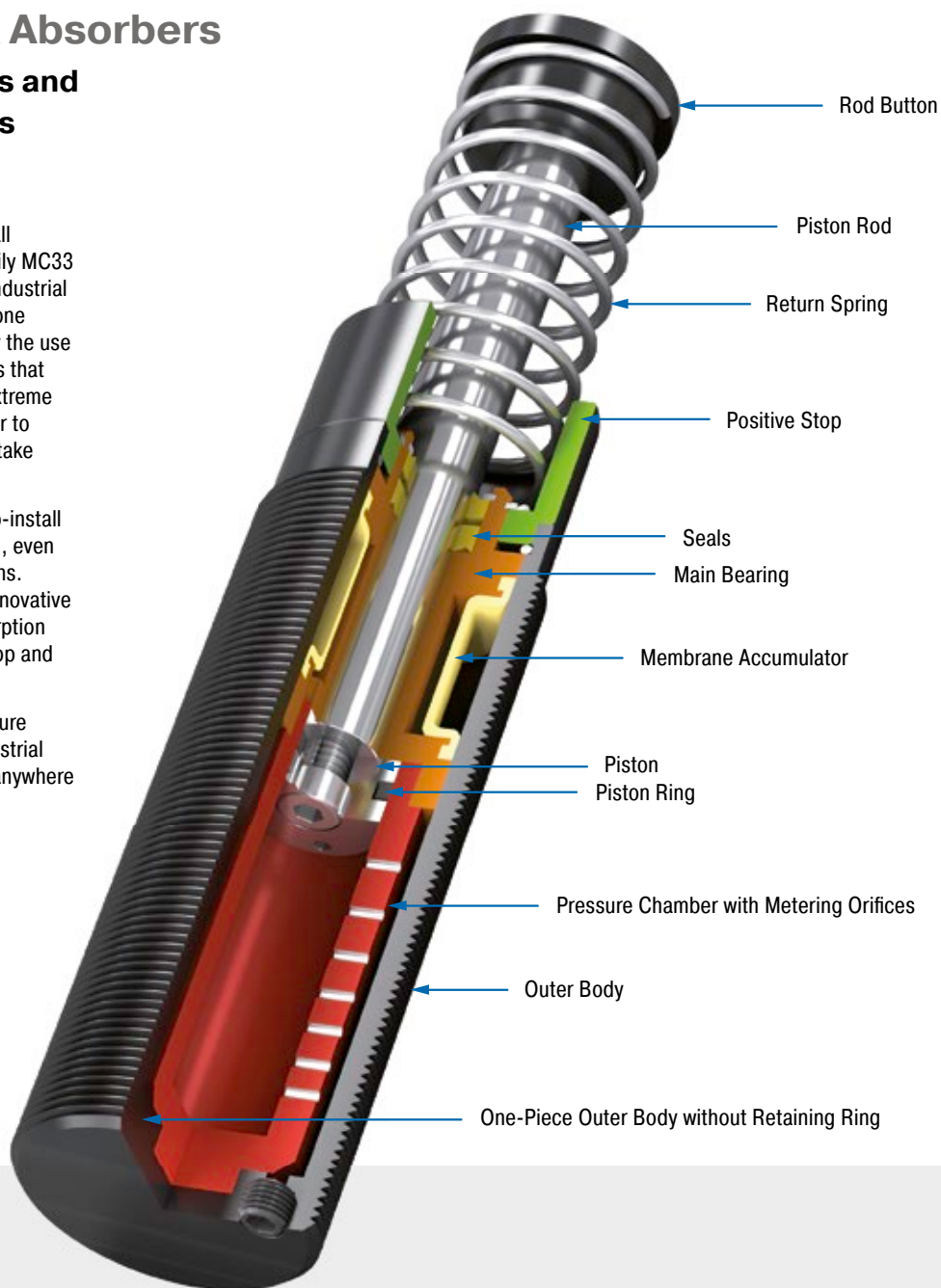

Technical Data

Energy capacity: 155 Nm/Cycle to 3,400 Nm/Cycle

Impact velocity range: 0.15 m/s to 5 m/s. Other speeds on request.

Operating temperature range: 0 °C to 150 °C

Mounting: In any position

Positive stop: Integrated

Material: Outer body: Nitride hardened steel; Piston rod: Hard chrome plated steel; Rod end button: Hardened steel and corrosion-resistant coating; Return spring: Zinc plated or plastic-

coated steel; Accessories: Steel with black oxide finish or nitride hardened

Damping medium: Synthetic high temperature oil

Application field: Linear slides, Swivel units, Turntables, Machines and plants

Note: A noise reduction of 3 to 7 dB is possible when using the special impact button (PP).

Safety instructions: External materials in the surrounding area can attack the seal components and lead to a shorter service life. Please contact ACE for appropriate solution sugges-

tions. Do not paint the shock absorbers due to heat emission.

On request: Nickel-plated, increased corrosion protection, mounting inside air cylinders or other special options are available on request. Adjustable HT and LT shock absorbers.

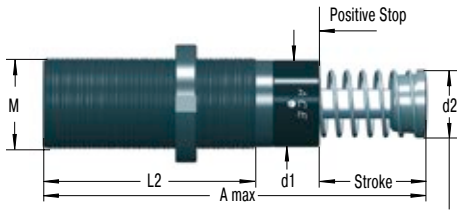
MC33EUM-HT

Note: 150 mm stroke model does not include stop collar and positive stop is provided by the rod button (Ø 60 mm)

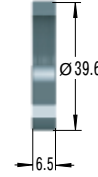
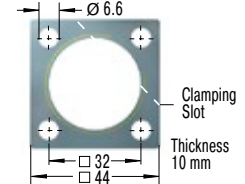
**NM33
Locking Ring**

**QF33
Square Flange**

Torque max.: 11 Nm
Clamping torque: > 90 Nm
Install with 4 machine screws

The calculation and selection of the most suitable damper should be carried out or be approved by ACE.

Complete details required when ordering

- Load to be decelerated: m (kg)
- Impact velocity: v (m/s)
- Propelling force: F (N)
- Operating cycles per hour: c (/hr)
- Number of absorbers in parallel: n
- Ambient temperature: °C

Ordering Example

- Self-Compensating _____
 - Thread Size M33 _____
 - Stroke 50 mm _____
 - EU Compliant _____
 - Metric Thread (omitted when using thread UNF) _____
 - Effective Weight Range Code _____
 - HT = Version for High Temperature Use _____
- MC3350EUM-2-HT**

Dimensions

TYPES	Stroke mm	A max. mm	d1 mm	d2 mm	L2 mm	M
MC3325EUM-HT	23.2	138	30	25	83	M33x1.5
MC3350EUM-HT	48.6	189	30	25	108	M33x1.5

Performance

TYPES	Max. Energy Capacity			Effective Weight			Hardness	° Side Load Angle max.	Weight kg
	W ₂ Nm/cycle	W ₄ at 20 °C Nm/h	W ₄ at 100 °C Nm/h	¹ me min. kg	¹ me max. kg				
MC3325EUM-0-HT	155	215,000	82,000	3	11	-0	4	0.45	
MC3325EUM-1-HT	155	215,000	82,000	9	40	-1	4	0.45	
MC3325EUM-2-HT	155	215,000	82,000	30	120	-2	4	0.45	
MC3325EUM-3-HT	155	215,000	82,000	100	420	-3	4	0.45	
MC3325EUM-4-HT	155	215,000	82,000	350	1,420	-4	4	0.45	
MC3350EUM-0-HT	310	244,000	93,000	5	22	-0	3	0.54	
MC3350EUM-1-HT	310	244,000	93,000	18	70	-1	3	0.54	
MC3350EUM-2-HT	310	244,000	93,000	60	250	-2	3	0.54	
MC3350EUM-3-HT	310	244,000	93,000	240	840	-3	3	0.54	
MC3350EUM-4-HT	310	244,000	93,000	710	2,830	-4	3	0.54	

¹ The effective weight range limits can be raised or lowered to special order.

² For applications with higher side load angles consider using the side load adaptor (BV) pages 74 to 77.

Self-Compensating

MC45EUM-HT

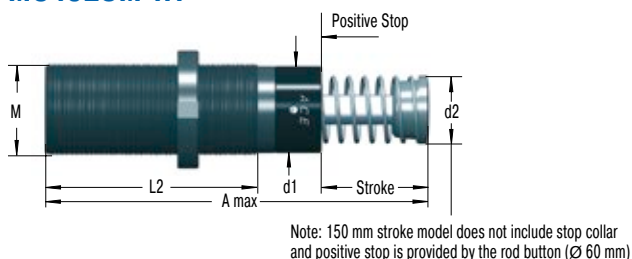

NM45 Locking Ring

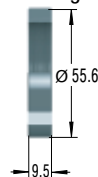

QF45 Square Flange

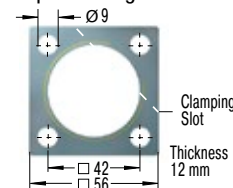

Torque max.: 27 Nm
Clamping torque: > 200 Nm
Install with 4 machine screws

The calculation and selection of the most suitable damper should be carried out or be approved by ACE.

Complete details required when ordering

- Load to be decelerated: m (kg)
- Impact velocity: v (m/s)
- Propelling force: F (N)
- Operating cycles per hour: c (/hr)
- Number of absorbers in parallel: n
- Ambient temperature: °C

Ordering Example

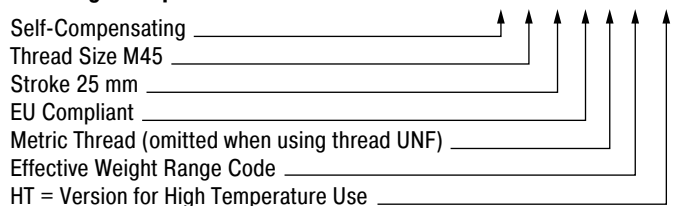

Dimensions

TYPES	Stroke mm	A max. mm	d1 mm	d2 mm	L2 mm	M
MC4525EUM-HT	23.1	145	42	35	95	M45x1.5
MC4550EUM-HT	48.5	195	42	35	120	M45x1.5

Performance

TYPES	Max. Energy Capacity			Effective Weight			Hardness	² Side Load Angle max. °	Weight kg
	W ₃ Nm/cycle	W ₄ at 20 °C Nm/h	W ₄ at 100 °C Nm/h	¹ me min. kg	¹ me max. kg				
MC4525EUM-0-HT	340	307,000	117,000	7	27	-0	4	1.13	
MC4525EUM-1-HT	340	307,000	117,000	20	90	-1	4	1.13	
MC4525EUM-2-HT	340	307,000	117,000	80	310	-2	4	1.13	
MC4525EUM-3-HT	340	307,000	117,000	260	1,050	-3	4	1.13	
MC4525EUM-4-HT	340	307,000	117,000	890	3,540	-4	4	1.13	
MC4550EUM-0-HT	680	321,000	122,000	13	54	-0	3	1.36	
MC4550EUM-1-HT	680	321,000	122,000	45	180	-1	3	1.36	
MC4550EUM-2-HT	680	321,000	122,000	150	620	-2	3	1.36	
MC4550EUM-3-HT	680	321,000	122,000	520	2,090	-3	3	1.36	
MC4550EUM-4-HT	680	321,000	122,000	1,800	7,100	-4	3	1.36	

¹ The effective weight range limits can be raised or lowered to special order.
² For applications with higher side load angles consider using the side load adaptor (BV) pages 74 to 77.

MC64EUM-HT

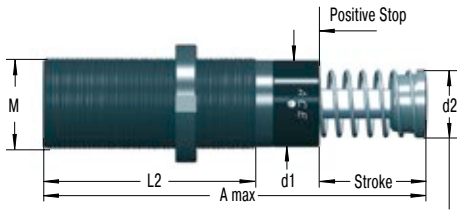

Note: 150 mm stroke model does not include stop collar and positive stop is provided by the rod button (Ø 60 mm)

NM64 Locking Ring

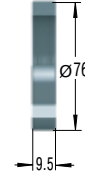

QF64 Square Flange

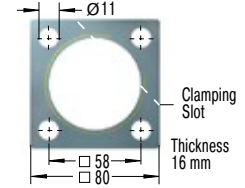

Torque max.: 50 Nm
Clamping torque: > 210 Nm
Install with 4 machine screws

The calculation and selection of the most suitable damper should be carried out or be approved by ACE.

Complete details required when ordering

- Load to be decelerated: m (kg)
- Impact velocity: v (m/s)
- Propelling force: F (N)
- Operating cycles per hour: c (/hr)
- Number of absorbers in parallel: n
- Ambient temperature: °C

Ordering Example

- Self-Compensating _____
 - Thread Size M64 _____
 - Stroke 50 mm _____
 - EU Compliant _____
 - Metric Thread (omitted when using thread UNF) _____
 - Effective Weight Range Code _____
 - HT = Version for High Temperature Use _____
- MC6450EUM-1-HT**

Dimensions

TYPES	Stroke mm	A max. mm	d1 mm	d2 mm	L2 mm	M
MC6450EUM-HT	48.6	225	60	48	140	M64x2
MC64100EUM-HT	99.4	326	60	48	191	M64x2

Performance

TYPES	Max. Energy Capacity			Effective Weight		Hardness	° Side Load Angle max.	Weight kg
	W ₂ Nm/cycle	W ₄ at 20 °C Nm/h	W ₄ at 100 °C Nm/h	¹ me min. kg	¹ me max. kg			
MC6450EUM-0-HT	1,700	419,000	159,000	35	140	-0	4	2.90
MC6450EUM-1-HT	1,700	419,000	159,000	140	540	-1	4	2.90
MC6450EUM-2-HT	1,700	419,000	159,000	460	1,850	-2	4	2.90
MC6450EUM-3-HT	1,700	419,000	159,000	1,600	6,300	-3	4	2.90
MC6450EUM-4-HT	1,700	419,000	159,000	5,300	21,200	-4	4	2.90
MC64100EUM-0-HT	3,400	550,000	200,000	70	280	-0	3	3.70
MC64100EUM-1-HT	3,400	550,000	200,000	270	1,100	-1	3	3.70
MC64100EUM-2-HT	3,400	550,000	200,000	930	3,700	-2	3	3.70
MC64100EUM-3-HT	3,400	550,000	200,000	3,150	12,600	-3	3	3.70
MC64100EUM-4-HT	3,400	550,000	200,000	10,600	42,500	-4	3	3.70

¹ The effective weight range limits can be raised or lowered to special order.
² For applications with higher side load angles consider using the side load adaptor (BV) pages 74 to 77.

MC33-LT to MC64-LT

Industrial Shock Absorbers

Extreme temperatures and high cycle frequencies

Further possibilities of use: Just like all MAGNUM types from the product family MC33 to MC64, the LT (low temperature) industrial shock absorbers are also made from one solid piece. They are characterised by the use of special seals and fluids. This means that these versions can even be used at extreme temperatures of $-50\text{ }^{\circ}\text{C}$ to $+66\text{ }^{\circ}\text{C}$ in order to safely and reliably damp masses and take away 100 % kinetic energy.

There is no reason why these ready-to-install machine elements should not be used, even under the most unfavourable conditions. Additional benefits are their robust, innovative sealing technology, high energy absorption in a compact design, fixed positive stop and a wide damping range.

Designed for use in extreme temperature ranges, these self-compensating industrial shock absorbers are suitable almost anywhere in plant and mechanical engineering.

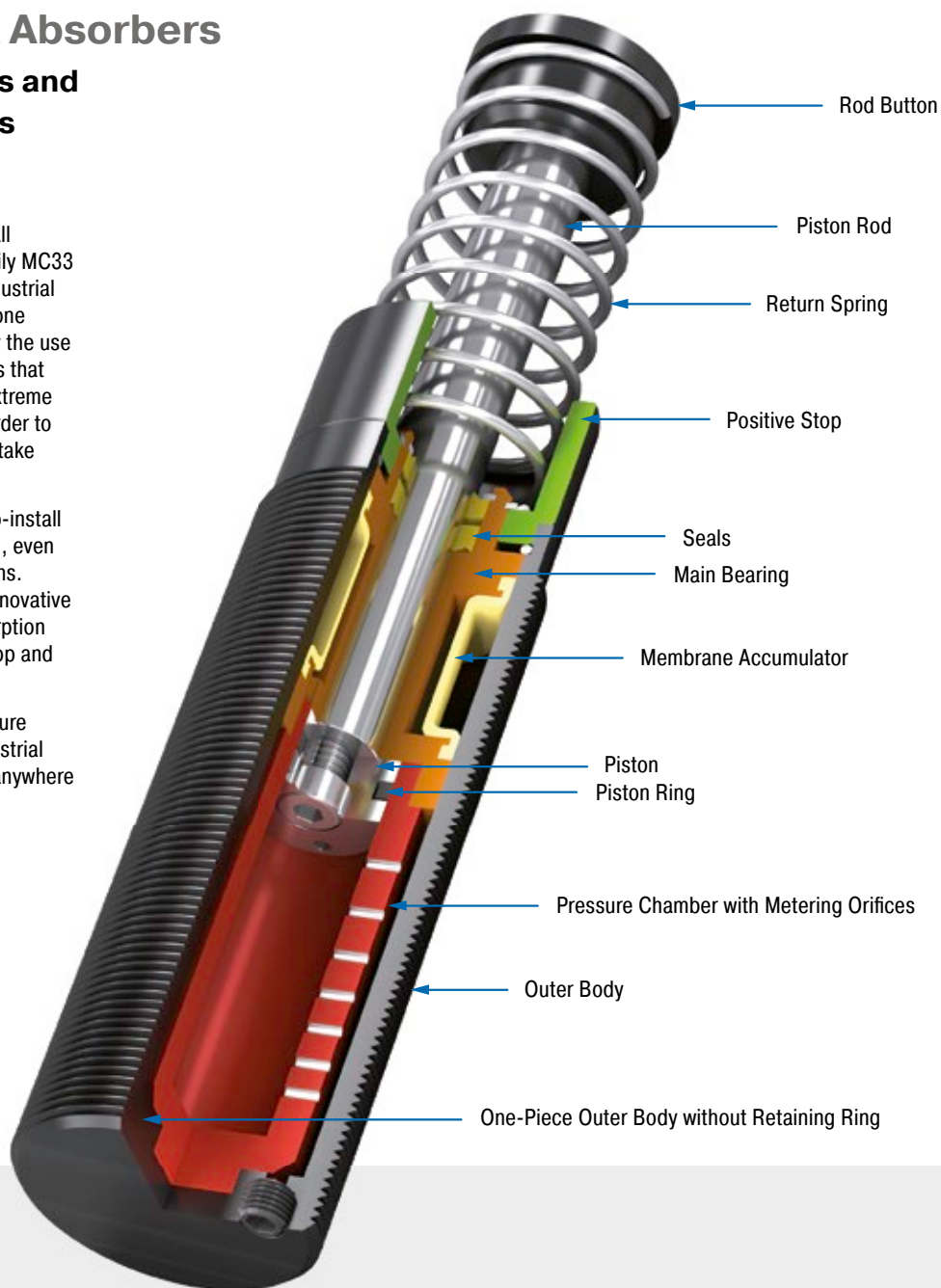

Technical Data

Energy capacity: 155 Nm/Cycle to 5,100 Nm/Cycle

Impact velocity range: 0.15 m/s to 5 m/s. Other speeds on request.

Operating temperature range: $-50\text{ }^{\circ}\text{C}$ to $+66\text{ }^{\circ}\text{C}$

Mounting: In any position

Positive stop: Integrated

Material: Outer body: Nitride hardened steel; Piston rod: Hard chrome plated steel; Rod end button: Hardened steel and corrosion-resistant coating; Return spring: Zinc plated or plastic-

coated steel; Accessories: Steel with black oxide finish or nitride hardened

Damping medium: Low temperature hydraulic oil

Application field: Linear slides, Swivel units, Turntables, Machines and plants

Note: A noise reduction of 3 to 7 dB is possible when using the special impact button (PP).

Safety instructions: External materials in the surrounding area can attack the seal components and lead to a shorter service life. Please contact ACE for appropriate solution sugges-

tions. Do not paint the shock absorbers due to heat emission.

On request: Nickel-plated, increased corrosion protection, mounting inside air cylinders or other special options are available on request. Adjustable HT and LT shock absorbers.

MC33EUM-LT

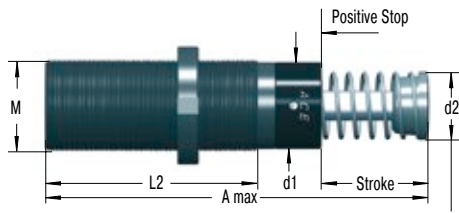

Note: 150 mm stroke model does not include stop collar and positive stop is provided by the rod button (Ø 60 mm)

NM33 Locking Ring

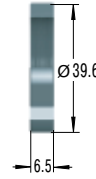

QF33 Square Flange

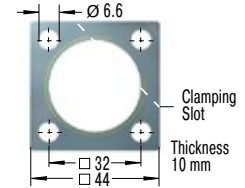

Torque max.: 11 Nm
Clamping torque: > 90 Nm
Install with 4 machine screws

The calculation and selection of the most suitable damper should be carried out or be approved by ACE.

Complete details required when ordering

- Load to be decelerated: m (kg)
- Impact velocity: v (m/s)
- Propelling force: F (N)
- Operating cycles per hour: c (/hr)
- Number of absorbers in parallel: n
- Ambient temperature: °C

Ordering Example

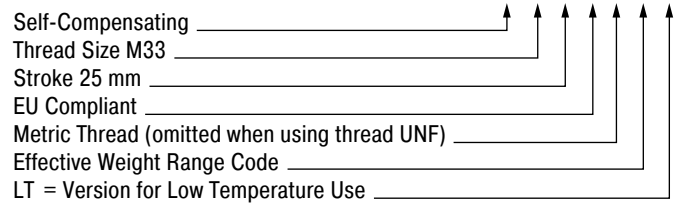

Dimensions							
TYPES	Stroke mm	A max. mm	d1 mm	d2 mm	L2 mm	M	
MC3325EUM-LT	23.2	138	30	25	83	M33x1.5	
MC3350EUM-LT	48.6	189	30	25	108	M33x1.5	

Performance								
TYPES	Max. Energy Capacity		Effective Weight			² Return time s	³ Side Load Angle max. °	Weight kg
	W ₃ Nm/cycle	W ₄ Nm/h	¹ me min. kg	¹ me max. kg	Hardness			
MC3325EUM-0-LT	155	75,000	3	11	-0	0.08	4	0.45
MC3325EUM-1-LT	155	75,000	9	40	-1	0.08	4	0.45
MC3325EUM-2-LT	155	75,000	30	120	-2	0.08	4	0.45
MC3325EUM-3-LT	155	75,000	100	420	-3	0.08	4	0.45
MC3325EUM-4-LT	155	75,000	350	1,420	-4	0.08	4	0.45
MC3350EUM-0-LT	310	85,000	5	22	-0	0.16	3	0.54
MC3350EUM-1-LT	310	85,000	18	70	-1	0.16	3	0.54
MC3350EUM-2-LT	310	85,000	60	250	-2	0.16	3	0.54
MC3350EUM-3-LT	310	85,000	240	840	-3	0.16	3	0.54
MC3350EUM-4-LT	310	85,000	710	2,830	-4	0.16	3	0.54

¹ The effective weight range limits can be raised or lowered to special order.
² at -50 °C

³ For applications with higher side load angles consider using the side load adaptor (BV) pages 74 to 77.

Self-Compensating

MC45EUM-LT

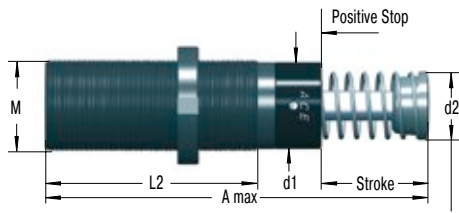

Note: 150 mm stroke model does not include stop collar and positive stop is provided by the rod button (Ø 60 mm)

NM45 Locking Ring

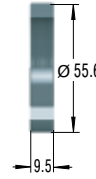

QF45 Square Flange

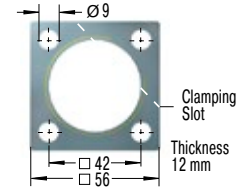

Torque max.: 27 Nm
Clamping torque: > 200 Nm
Install with 4 machine screws

The calculation and selection of the most suitable damper should be carried out or be approved by ACE.

Complete details required when ordering

- Load to be decelerated: m (kg)
- Impact velocity: v (m/s)
- Propelling force: F (N)
- Operating cycles per hour: c (/hr)
- Number of absorbers in parallel: n
- Ambient temperature: °C

Ordering Example

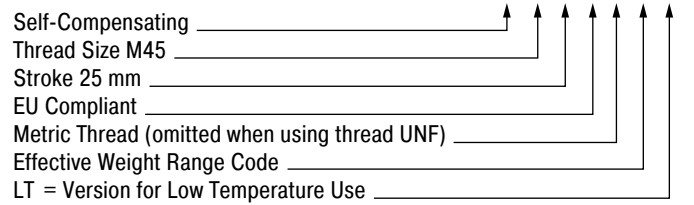

Dimensions

TYPES	Stroke mm	A max. mm	d1 mm	d2 mm	L2 mm	M
MC4525EUM-LT	23.1	145	42	35	95	M45x1.5
MC4550EUM-LT	48.5	195	42	35	120	M45x1.5
MC4575EUM-LT	73.9	246	42	35	145	M45x1.5

Performance

TYPES	Max. Energy Capacity		Effective Weight			Return time s	Side Load Angle max. °	Weight kg
	W ₃ Nm/cycle	W ₄ Nm/h	¹ me min. kg	¹ me max. kg	Hardness			
MC4525EUM-0-LT	340	107,000	7	27	-0	0.08	4	1.13
MC4525EUM-1-LT	340	107,000	20	90	-1	0.08	4	1.13
MC4525EUM-2-LT	340	107,000	80	310	-2	0.08	4	1.13
MC4525EUM-3-LT	340	107,000	260	1,050	-3	0.08	4	1.13
MC4525EUM-4-LT	340	107,000	890	3,540	-4	0.08	4	1.13
MC4550EUM-0-LT	680	112,000	13	54	-0	0.16	3	1.36
MC4550EUM-1-LT	680	112,000	45	180	-1	0.16	3	1.36
MC4550EUM-2-LT	680	112,000	150	620	-2	0.16	3	1.36
MC4550EUM-3-LT	680	112,000	520	2,090	-3	0.16	3	1.36
MC4550EUM-4-LT	680	112,000	1,800	7,100	-4	0.16	3	1.36
MC4575EUM-0-LT	1,020	146,000	20	80	-0	0.24	2	1.59
MC4575EUM-1-LT	1,020	146,000	20	80	-1	0.24	2	1.59
MC4575EUM-2-LT	1,020	146,000	70	270	-2	0.24	2	1.59
MC4575EUM-3-LT	1,020	146,000	230	930	-3	0.24	2	1.59
MC4575EUM-4-LT	1,020	146,000	2,650	10,600	-4	0.24	2	1.59

¹ The effective weight range limits can be raised or lowered to special order.
² at -50 °C
³ For applications with higher side load angles consider using the side load adaptor (BV) pages 74 to 77.

MC64EUM-LT

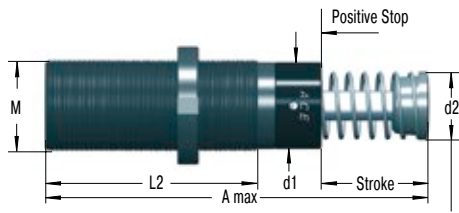

Note: 150 mm stroke model does not include stop collar and positive stop is provided by the rod button (Ø 60 mm)

NM64 Locking Ring

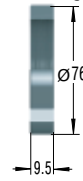

QF64 Square Flange

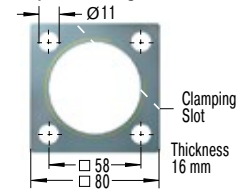

Torque max.: 50 Nm
Clamping torque: > 210 Nm
Install with 4 machine screws

The calculation and selection of the most suitable damper should be carried out or be approved by ACE.

Complete details required when ordering

- Load to be decelerated: m (kg)
- Impact velocity: v (m/s)
- Propelling force: F (N)
- Operating cycles per hour: c (/hr)
- Number of absorbers in parallel: n
- Ambient temperature: °C

Ordering Example

- Self-Compensating MC6450EUM-4-LT
- Thread Size M64
- Stroke 50 mm
- EU Compliant
- Metric Thread (omitted when using thread UNF)
- Effective Weight Range Code
- LT = Version for Low Temperature Use

Dimensions

TYPES	Stroke mm	A max. mm	d1 mm	d2 mm	L2 mm	M
MC6450EUM-LT	48.6	225	60	48	140	M64x2
MC64100EUM-LT	99.4	326	60	48	191	M64x2
MC64150EUM-LT	150	450	60	48	241	M64x2

Performance

TYPES	Max. Energy Capacity		Effective Weight			² Return time s	³ Side Load Angle max. °	Weight kg
	W ₃ Nm/cycle	W ₄ Nm/h	¹ me min. kg	¹ me max. kg	Hardness			
MC6450EUM-0-LT	1,700	146,000	35	140	-0	0.24	4	2.9
MC6450EUM-1-LT	1,700	146,000	140	540	-1	0.24	4	2.9
MC6450EUM-2-LT	1,700	146,000	460	1,850	-2	0.24	4	2.9
MC6450EUM-3-LT	1,700	146,000	1,600	6,300	-3	0.24	4	2.9
MC6450EUM-4-LT	1,700	146,000	5,300	21,200	-4	0.24	4	2.9
MC64100EUM-0-LT	3,400	192,000	70	280	-0	0.68	3	3.7
MC64100EUM-1-LT	3,400	192,000	270	1,100	-1	0.68	3	3.7
MC64100EUM-2-LT	3,400	192,000	930	3,700	-2	0.68	3	3.7
MC64100EUM-3-LT	3,400	192,000	3,150	12,600	-3	0.68	3	3.7
MC64100EUM-4-LT	3,400	192,000	10,600	42,500	-4	0.68	3	3.7
MC64150EUM-0-LT	5,100	248,000	100	460	-0	0.96	2	5.1
MC64150EUM-1-LT	5,100	248,000	410	1,640	-1	0.96	2	5.1
MC64150EUM-2-LT	5,100	248,000	1,390	5,600	-2	0.96	2	5.1
MC64150EUM-3-LT	5,100	248,000	4,700	18,800	-3	0.96	2	5.1
MC64150EUM-4-LT	5,100	248,000	16,000	63,700	-4	0.96	2	5.1

¹ The effective weight range limits can be raised or lowered to special order.

² at -50 °C

³ For applications with higher side load angles consider using the side load adaptor (BV) pages 74 to 77.

SC33 to SC45 Industrial Shock Absorbers

Piston tube design for maximum energy absorption

True performers: The combination the proven sealing technology from the MAGNUM series including membrane accumulator with the well-known piston tube technology from the SC² family makes the SC33 to 45 absorber models so strong and durable. The increase of the oil volume ensures the maximum braking forces. Short stroke lengths of 25 to 50 mm lead to shorter braking times in combination with a high energy absorption.

These dampers safely and reliably decelerate rotary movements without unwanted recoil effects. Assembly close to the pivot point is possible. The low impact speeds with this are managed with ease by ACE's generation of piston tubes.

These self-compensating industrial shock absorbers can be relied on in mechanical engineering. They are used in pivot units, rotary tables, robot arms or integrated else where in construction designs.

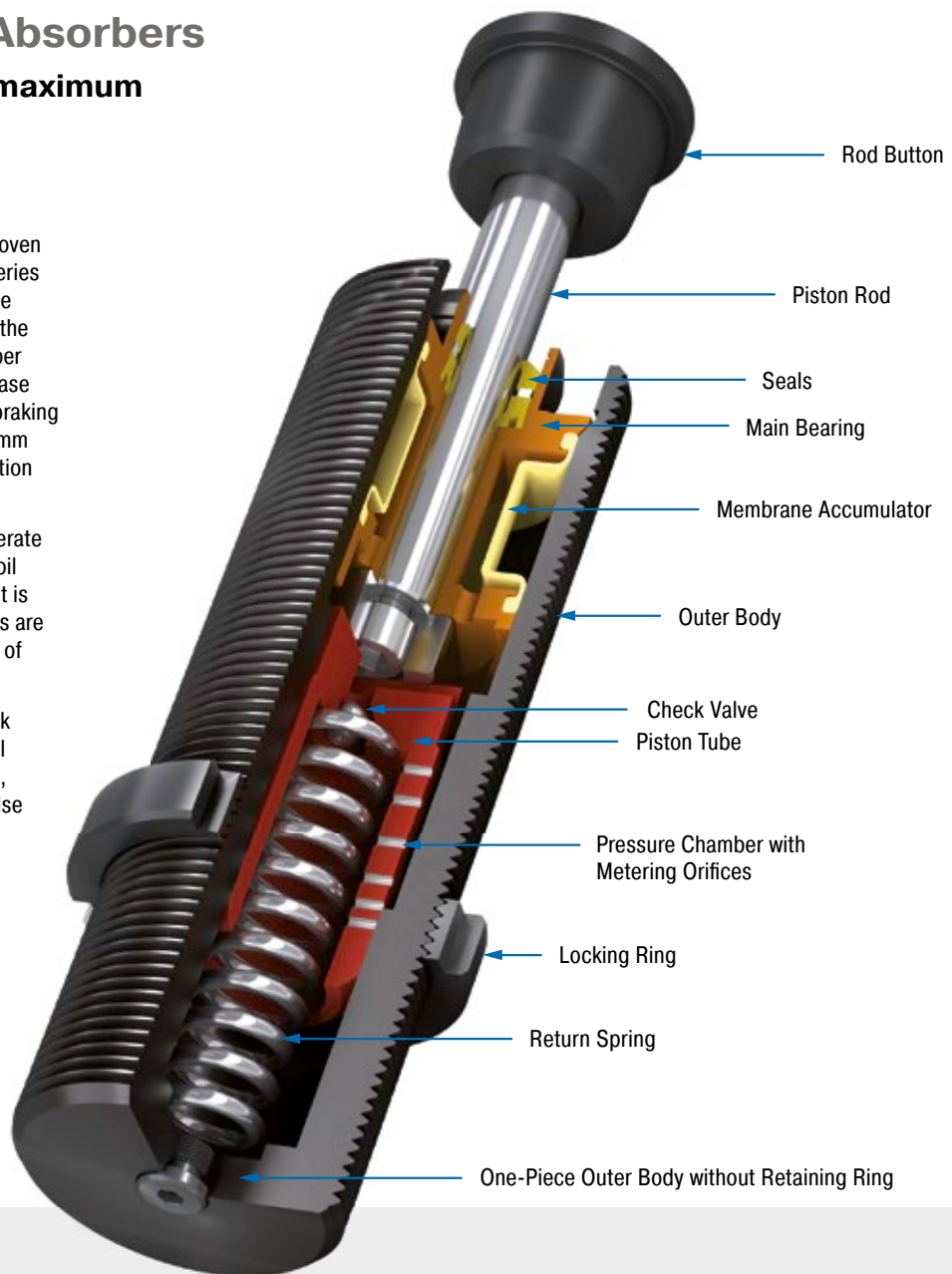

Technical Data

Energy capacity: 155 Nm/Cycle to 680 Nm/Cycle

Impact velocity range: 0.02 m/s to 0.46 m/s. Other speeds on request.

Operating temperature range: -12 °C to +66 °C. Other temperatures on request.

Mounting: In any position

Positive stop: In any position

Material: Outer body: Nitride hardened steel; Piston rod: Hard chrome plated steel; Rod end button: Hardened steel and corrosion-resistant coating; Accessories: Steel with black oxide finish or nitride hardened

Damping medium: Low temperature hydraulic oil

Application field: Turntables, Swivel units, Robot arms, Linear slides

Note: A noise reduction of 3 to 7 dB is possible when using the special impact button (PP).

Safety instructions: External materials in the surrounding area can attack the seal components and lead to a shorter service life. Please contact ACE for appropriate solution suggestions. Do not paint the shock absorbers due to heat emission.

On request: Special oils, mounting inside air cylinders or other special options are available on request.

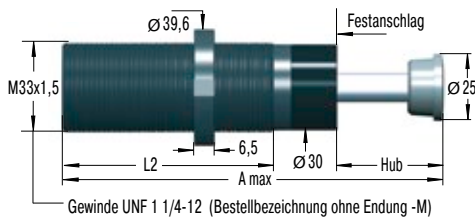
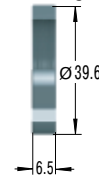
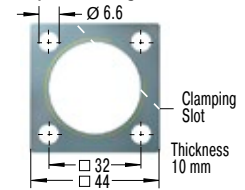
SC33EUM

NM33
Locking Ring

QF33
Square Flange

Torque max.: 11 Nm
Clamping torque: > 90 Nm
Install with 4 machine screws

The calculation and selection of the most suitable damper should be carried out or be approved by ACE.

Ordering Example

Self-Compensating _____ **SC3325EUM-5**
 Thread Size M33 _____
 Stroke 25 mm _____
 EU Compliant _____
 Metric Thread _____
 (omitted when using thread UNF 1 1/4-12)
 Effective Weight Range Version _____

Dimensions

TYPES	Stroke mm	A max. mm	L2 mm
SC3325EUM	23.2	178	122
SC3350EUM	48.6	254	173

Performance

TYPES	Max. Energy Capacity		Effective Weight			² Side Load Angle				
	W ₃ Nm/cycle	W ₄ Nm/h	¹ me min. kg	¹ me max. kg	Hardness	Return force min. N	Return force max. N	Return time s	max. °	Weight kg
SC3325EUM-5	155	75,000	1,360	2,721	-5	44	89	0.75	4	1.13
SC3325EUM-6	155	75,000	2,500	5,443	-6	44	89	0.75	4	1.13
SC3325EUM-7	155	75,000	4,989	8,935	-7	44	89	0.75	4	1.13
SC3325EUM-8	155	75,000	8,618	13,607	-8	44	89	0.75	4	1.13
SC3350EUM-5	310	85,000	2,721	4,990	-5	51	125	0.90	3	1.36
SC3350EUM-6	310	85,000	4,536	9,980	-6	51	125	0.90	3	1.36

¹ The effective weight range limits can be raised or lowered to special order.

² For applications with higher side load angles consider using the side load adaptor (BV) pages 74 to 77.

Self-Compensating, Piston Tube Technology

SC45EUM

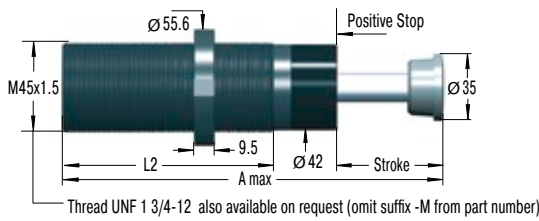

NM45 Locking Ring

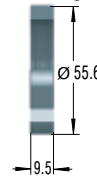

QF45 Square Flange

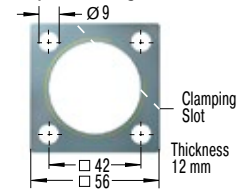

Torque max.: 27 Nm
Clamping torque: > 200 Nm
Install with 4 machine screws

The calculation and selection of the most suitable damper should be carried out or be approved by ACE.

Ordering Example

SC4525EUM-5

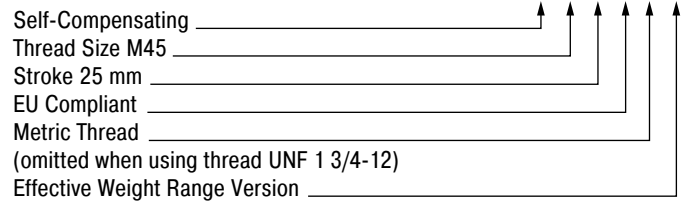

Dimensions

TYPES	Stroke mm	A max. mm	L2 mm
SC4525EUM	23.1	189	139
SC4550EUM	48.5	265	190

Performance

TYPES	Max. Energy Capacity		Effective Weight			Side Load Angle				
	W ₃ Nm/cycle	W ₄ Nm/h	¹ me min. kg	¹ me max. kg	Hardness	Return force min. N	Return force max. N	Return time s	² max. °	Weight kg
SC4525EUM-5	340	107,000	3,400	6,800	-5	67	104	0.8	4	1.27
SC4525EUM-6	340	107,000	6,350	13,600	-6	67	104	0.8	4	1.27
SC4525EUM-7	340	107,000	12,700	22,679	-7	67	104	0.8	4	1.27
SC4525EUM-8	340	107,000	20,411	39,000	-8	67	104	0.8	4	1.27
SC4550EUM-5	680	112,000	6,800	12,246	-5	47	242	1.0	3	1.49
SC4550EUM-6	680	112,000	11,790	26,988	-6	47	242	1.0	3	1.49
SC4550EUM-7	680	112,000	25,854	44,225	-7	47	242	1.0	3	1.49

¹ The effective weight range limits can be raised or lowered to special order.
² For applications with higher side load angles consider using the side load adaptor (BV) pages 74 to 77.

ACE Sneak Preview

Autumn 2016

NEW



Pallet Stoppers

pneumatic, hydraulic, electric
or combined version

For all information see our Website
and the new Special Catalogue.

Adjustable

MA/ML33 to MA/ML64

Industrial Shock Absorbers

High energy absorption and progressive adjustment

Adjustable and unique: These industrial shock absorbers from ACE, which can be precisely adjusted both at the front and rear, also contribute towards the success of the MAGNUM series. Equipped with excellent sealing technology, an annealed guide bearing and integrated positive stop, they are robust and durable.

These dampers absorb 50 % more energy than their predecessors but are built even more compactly. The larger range of effective loads also opens up various options in design and assembly. This makes the ML series especially suitable for effective loads of 300 kg to 500,000 kg. Where work is done with changing application data and wherever flexibility is required, they make the best option.

These adjustable industrial shock absorbers are used in all areas of mechanical engineering – e.g. in automation, integrated in linear carriages or pivoting units and also for gantries.

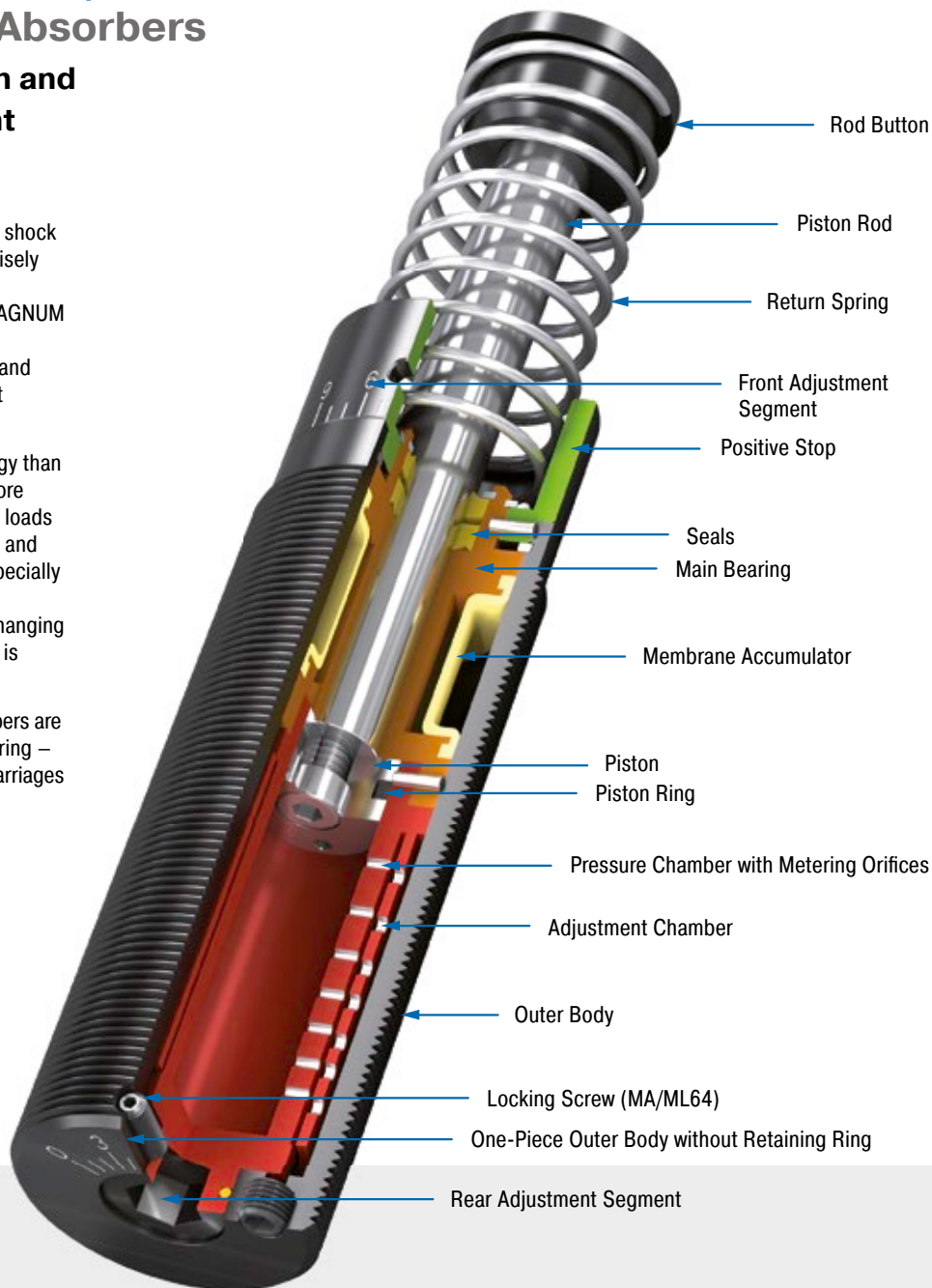

Technical Data

Energy capacity: 170 Nm/Cycle to 6,120 Nm/Cycle

Impact velocity range: MA: 0.15 m/s to 5 m/s. ML: 0.02 m/s to 0.46 m/s. Other speeds on request.

Operating temperature range: -12 °C to +66 °C

Other temperatures on request.

Mounting: In any position

Positive stop: Integrated

Adjustment: Hard impact at the start of stroke, adjust the ring towards 9 or PLUS. Hard impact at the end of stroke, adjust the ring towards 0 or MINUS.

Material: Outer body: Nitride hardened steel; Piston rod: Hard chrome plated steel; Rod end button: Hardened steel and corrosion-resistant coating; Return spring: Zinc plated or plastic-coated steel; Accessories: Steel with black oxide finish or nitride hardened

Damping medium: Automatic Transmission Fluid (ATF)

Application field: Linear slides, Swivel units, Turntables, Portal systems

Note: A noise reduction of 3 to 7 dB is possible when using the special impact button (PP). For emergency use only applications and for continuous use (with additional cooling) it is sometimes possible to exceed the published

max. capacity ratings. In this case, please consult ACE.

Safety instructions: External materials in the surrounding area can attack the seal components and lead to a shorter service life. Please contact ACE for appropriate solution suggestions. Do not paint the shock absorbers due to heat emission.

On request: Special oils, nickel-plated, increased corrosion protection, mounting inside air cylinders or other special options are available on request.

MA/ML33EUM

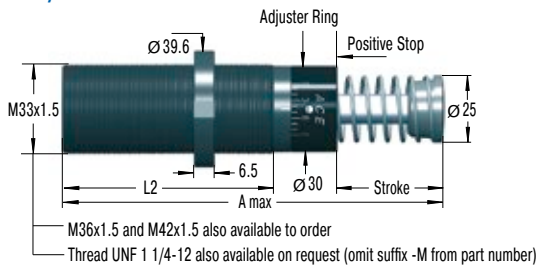

NM33 Locking Ring

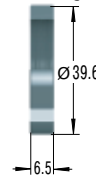

QF33 Square Flange

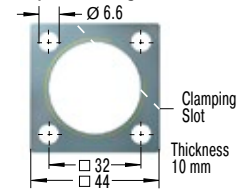

Torque max.: 11 Nm
Clamping torque: > 90 Nm
Install with 4 machine screws

The calculation and selection of the most suitable damper should be carried out or be approved by ACE.

Model Type Prefix

Standard Models

MA: Self-Contained with return spring, adjustable
ML: Self-Contained with return spring, adjustable, for lower impact velocity

Special Models

MAA, MLA: Air/Oil return without return spring. Use only with external air/oil tank.
MAS, MLS: Air/Oil Return with return spring. Use only with external air/oil tank.
MAN, MLN: Self-Contained without return spring

Ordering Example

Adjustable _____ ↑
Thread Size M33 _____ ↑
Stroke 50 mm _____ ↑
EU Compliant _____ ↑
Metric Thread _____ ↑
(omitted when using thread UNF 1 1/4-12)

MA/ML3350EUM

Dimensions

TYPES	Stroke mm	A max. mm	L2 mm
MA3325EUM	23.2	138	83
ML3325EUM	23.2	138	83
MA3350EUM	48.6	189	108
ML3350EUM	48.6	189	108

Performance

TYPES	Max. Energy Capacity				Effective Weight		Return force min. N	Return force max. N	Return time s	Side Load Angle max. °	Weight kg
	¹ W ₃ Nm/cycle	W ₄ Nm/h	W ₄ with Air/Oil Tank Nm/h	W ₄ with Oil Recirculation Nm/h	² me min. kg	² me max. kg					
MA3325EUM	170	75,000	124,000	169,000	9	1,700	45	90	0.03	4	0.45
ML3325EUM	170	75,000	124,000	169,000	300	50,000	45	90	0.03	4	0.45
MA3350EUM	340	85,000	135,000	180,000	13	2,500	45	135	0.06	3	0.54
ML3350EUM	340	85,000	135,000	180,000	500	80,000	45	135	0.06	3	0.54

¹ For emergency use only applications it is sometimes possible to exceed the above ratings. Please consult ACE for further details.

² The effective weight range limits can be raised or lowered to special order.

³ For applications with higher side load angles consider using the side load adaptor (BV) pages 74 to 77.

Adjustable

MA/ML45EUM

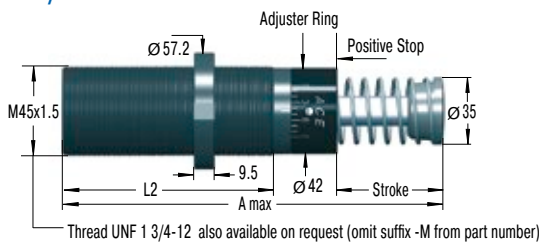

NM45 Locking Ring

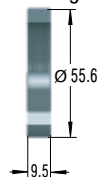

QF45 Square Flange

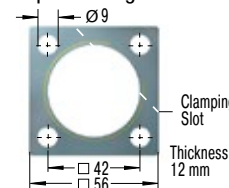

Torque max.: 27 Nm
Clamping torque: > 200 Nm
Install with 4 machine screws

The calculation and selection of the most suitable damper should be carried out or be approved by ACE.

Model Type Prefix

Standard Models

MA: Self-Contained with return spring, adjustable
ML: Self-Contained with return spring, adjustable, for lower impact velocity

Special Models

MAA, MLA: Air/Oil return without return spring.
Use only with external air/oil tank.
MAS, MLS: Air/Oil Return with return spring.
Use only with external air/oil tank.
MAN, MLN: Self-Contained without return spring

Ordering Example

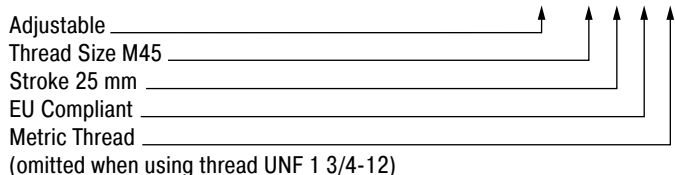

Dimensions			
TYPES	Stroke mm	A max. mm	L2 mm
MA4525EUM	23.1	145	95
ML4525EUM	23.1	145	95
MA4550EUM	48.5	195	120
ML4550EUM	48.5	195	120
MA4575EUM	73.9	246	145

Performance											
TYPES	Max. Energy Capacity				Effective Weight		Return force min. N	Return force max. N	Return time s	Side Load Angle max. °	Weight kg
	¹ W ₃ Nm/cycle	W ₄ Nm/h	W ₄ with Air/Oil Tank Nm/h	W ₄ with Oil Recirculation Nm/h	² me min. kg	² me max. kg					
MA4525EUM	390	107,000	158,000	192,000	40	10,000	70	100	0.03	4	1.13
ML4525EUM	390	107,000	158,000	192,000	3,000	110,000	70	100	0.03	4	1.13
MA4550EUM	780	112,000	192,000	248,000	70	14,500	70	145	0.08	3	1.36
ML4550EUM	780	112,000	192,000	248,000	5,000	180,000	70	145	0.08	3	1.36
MA4575EUM	1,170	146,000	225,000	282,000	70	15,000	50	180	0.11	2	1.59

¹ For emergency use only applications it is sometimes possible to exceed the above ratings. Please consult ACE for further details.
² The effective weight range limits can be raised or lowered to special order.
³ For applications with higher side load angles consider using the side load adaptor (BV) pages 74 to 77.

MA/ML64EUM

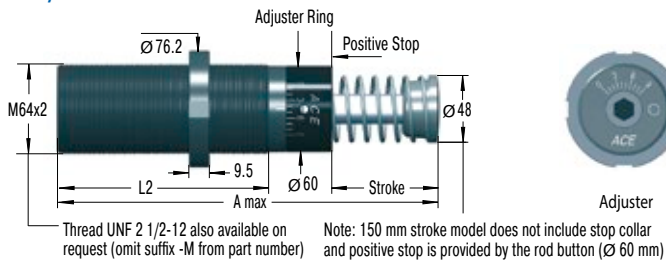

NM64 Locking Ring

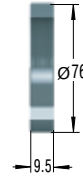

QF64 Square Flange

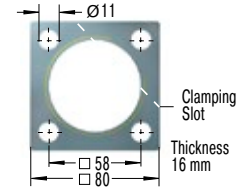

Torque max.: 50 Nm
Clamping torque: > 210 Nm
Install with 4 machine screws

The calculation and selection of the most suitable damper should be carried out or be approved by ACE.

Model Type Prefix

Standard Models

MA: Self-Contained with return spring, adjustable
ML: Self-Contained with return spring, adjustable, for lower impact velocity

Special Models

MAA, MLA: Air/Oil return without return spring.
Use only with external air/oil tank.
MAS, MLS: Air/Oil Return with return spring.
Use only with external air/oil tank.
MAN, MLN: Self-Contained without return spring

Ordering Example

Adjustable _____ MA/ML6450EUM
Thread Size M64 _____
Stroke 50 mm _____
EU Compliant _____
Metric Thread _____
(omitted when using thread UNF 2 1/2-12)

Dimensions

TYPES	Stroke mm	A max. mm	L2 mm
ML6425EUM	23.2	174	114
MA6450EUM	48.6	225	140
ML6450EUM	48.6	225	140
MA64100EUM	99.4	326	191
MA64150EUM	150	450	241

Performance

TYPES	Max. Energy Capacity				Effective Weight		Return force min. N	Return force max. N	Return time s	Side Load Angle max. °	Weight kg
	¹ W ₃ Nm/cycle	W ₄ Nm/h	W ₄ with Air/Oil Tank Nm/h	W ₄ with Oil Recirculation Nm/h	² me min. kg	² me max. kg					
ML6425EUM	1,020	124,000	248,000	332,000	7,000	300,000	120	155	0.06	5	2.5
MA6450EUM	2,040	146,000	293,000	384,000	220	50,000	90	155	0.12	4	2.9
ML6450EUM	2,040	146,000	293,000	384,000	11,000	500,000	90	155	0.12	4	2.9
MA64100EUM	4,080	192,000	384,000	497,000	270	52,000	105	270	0.34	3	3.7
MA64150EUM	6,120	248,000	497,000	644,000	330	80,000	75	365	0.48	2	5.1

¹ For emergency use only applications it is sometimes possible to exceed the above ratings. Please consult ACE for further details.

² The effective weight range limits can be raised or lowered to special order.

³ For applications with higher side load angles consider using the side load adaptor (BV) pages 74 to 77.

Overview

M33x1.5

S33
Side Foot Mounting Kit

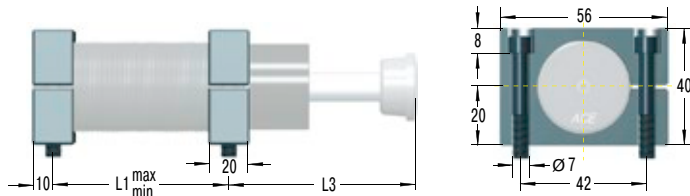

Dimensions		L1 min.	L1 max.	L3
TYPES		mm	mm	mm
MC, MA, ML3325EUM		25	60	68
MC, MA, ML3350EUM		32	86	93
SC3325EUM		40	98	66
SC3350EUM		60	153	92

S33 = 2 flanges + 4 screws M6x40, DIN 912
 Torque max.: 11 Nm
 Clamping torque: 90 Nm
 Because of the thread pitch the fixing holes for the second foot mount should only be drilled and tapped after the first foot mount has been fixed in position.

C33
Clevis Mounting Kit

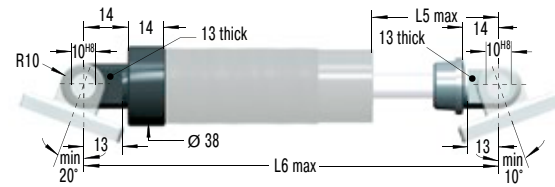

Dimensions		L5 max.	L6 max.
TYPES		mm	mm
MC, MA, ML3325EUM		39	168
MC, MA, ML3350EUM		64	218
SC3325EUM		39	208
SC3350EUM		64	283

C33 = 2 clevis eyes. Delivered assembled to shock absorber.
 Use positive stop at both ends of travel.

SF33
Clevis Flange

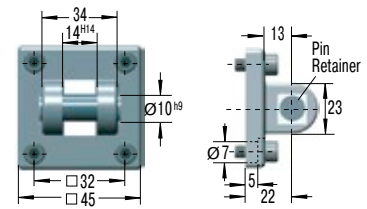

SF33 = flange + 4 screws M6x20, DIN 912
 Torque max.: 7.5 Nm
 Clamping torque: > 50 Nm
Secure with pin or use additional bar.
Due to limited force capacity the respective ability should be reviewed by ACE.

M33x1.5

NM33
Locking Ring

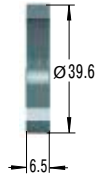

PP33
Poly Button

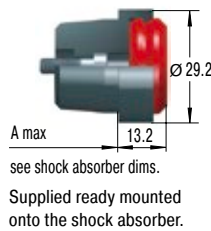

QF33
Square Flange

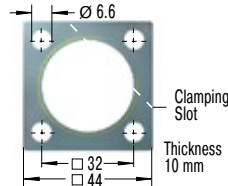

Torque max.: 11 Nm
 Clamping torque: > 90 Nm
 Install with 4 machine screws

AS33
Switch Stop Collar

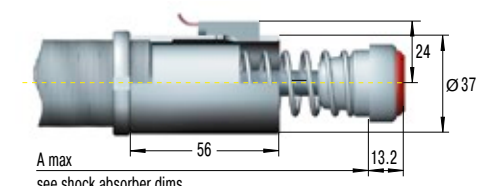

inc. Proximity Switch and Poly Button with elastomer insert

BV3325
Side Load Adaptor

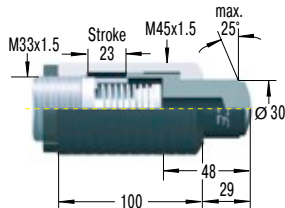

BV3350
Side Load Adaptor

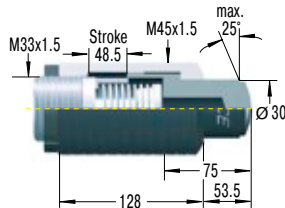

PB3325
Steel Shroud

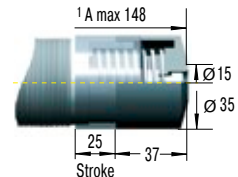

1 Total installation length of the shock absorber inc. steel shroud

PB3350
Steel Shroud

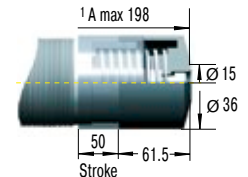

1 Total installation length of the shock absorber inc. steel shroud

Mounting, installation, ... see page 77.

M45x1.5

S45 Side Foot Mounting Kit

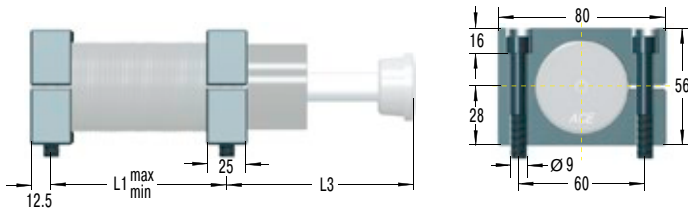

Dimensions

TYPES	L1 min. mm	L1 max. mm	L3 mm
MC, MA, ML4525EUM	32	66	66
MC, MA, ML4550EUM	40	92	91
MC, MA4575EUM	50	118	116
SC4525EUM	50	112	62.5
SC4550EUM	64	162	87.5

S45 = 2 flanges + 4 screws M8x50, DIN 912

Torque max.: 27 Nm

Clamping torque: 350 Nm

Because of the thread pitch the fixing holes for the second foot mount should only be drilled and tapped after the first foot mount has been fixed in position.

C45 Clevis Mounting Kit

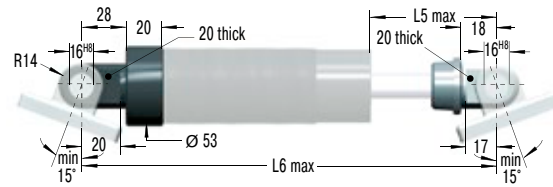

Dimensions

TYPES	L5 max. mm	L6 max. mm
MC, MA, ML4525EUM	43	200
MC, MA, ML4550EUM	68	250
MC, MA4575EUM	93	301
SC4525EUM	68	244
SC4550EUM	93	320

C45 = 2 clevis eyes. Delivered assembled to shock absorber. Use positive stop at both ends of travel.

SF45 Clevis Flange

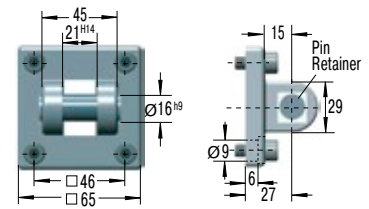

SF45 = flange + 4 screws M8x20, DIN 912
Torque max.: 7.5 Nm

Clamping torque: > 140 Nm

Secure with pin or use additional bar.

Due to limited force capacity the respective ability should be reviewed by ACE.

M45x1.5

NM45 Locking Ring

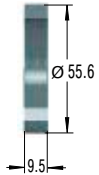

PP45 Poly Button

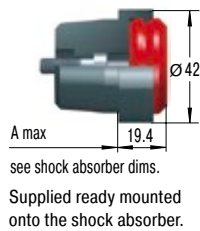

QF45 Square Flange

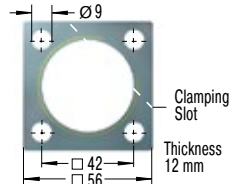

Torque max.: 27 Nm
Clamping torque: > 200 Nm
Install with 4 machine screws

AS45 Switch Stop Collar

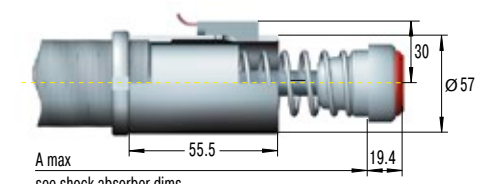

inc. Proximity Switch and Poly Button with elastomer insert

BV4525 Side Load Adaptor

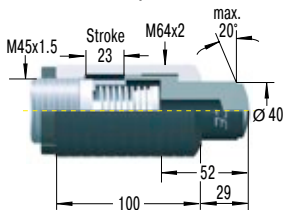

BV4550 Side Load Adaptor

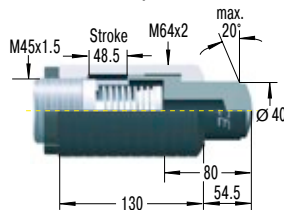

PB4525 Steel Shroud

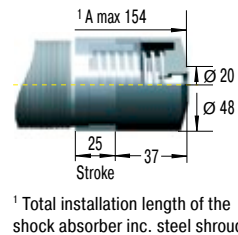

PB4550 Steel Shroud

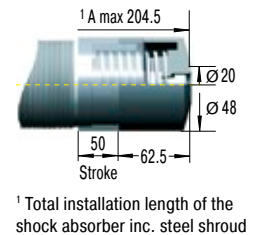

Overview

M64x2

S64

Side Foot Mounting Kit

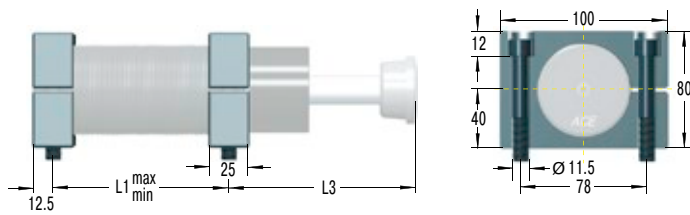

Dimensions			
TYPES	L1 min. mm	L1 max. mm	L3 mm
ML6425EUM	40	86	75.5
MC, MA, ML6450EUM	50	112	100
MC, MA64100EUM	64	162	152
MC, MA64150EUM	80	212	226

S64 = 2 flanges + 4 screws M10x80, DIN 912
 Torque max.: 50 Nm
 Clamping torque: 350 Nm
 Because of the thread pitch the fixing holes for the second foot mount should only be drilled and tapped after the first foot mount has been fixed in position.

C64

Clevis Mounting Kit

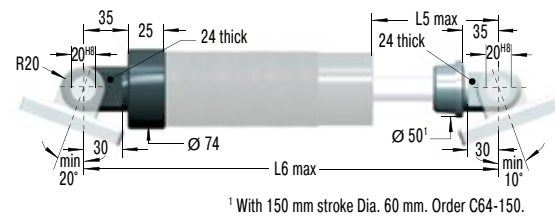

Dimensions		
TYPES	L5 max. mm	L6 max. mm
ML6425EUM	60	260
MC, MA, ML6450EUM	85	310
MC, MA64100EUM	136	410
MC, MA64150EUM	187	530

C64 = 2 clevis eyes. Delivered assembled to shock absorber.
¹ With 150 mm stroke Dia. 60 mm. Order C64-150.
¹ with 150 mm stroke Dia. 60 mm. Order C64-150.
 Use positive stop at both ends of travel.

SF64

Clevis Flange

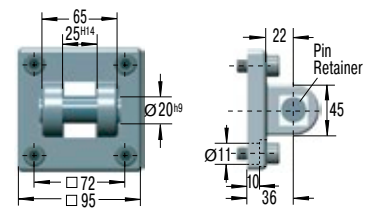

SF64 = flange + 4 screws M10x20, DIN 912
 Torque max.: 15 Nm
 Clamping torque: > 200 Nm
Secure with pin or use additional bar.
Due to limited force capacity the respective ability should be reviewed by ACE.

M64x2

NM64

Locking Ring

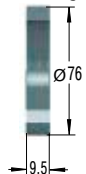

PP64

Poly Button

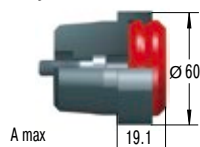

see shock absorber dims.
 Supplied ready mounted onto the shock absorber.

QF64

Square Flange

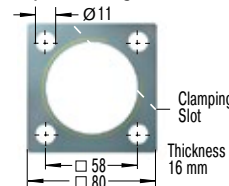

Torque max.: 50 Nm
 Clamping torque: > 210 Nm
 Install with 4 machine screws

QF90

Square Flange

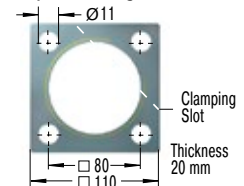

Torque max.: 50 Nm
 Clamping torque: > 210 Nm
 Install with 4 machine screws

BV6425

Side Load Adaptor

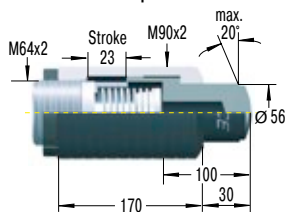

BV6450

Side Load Adaptor

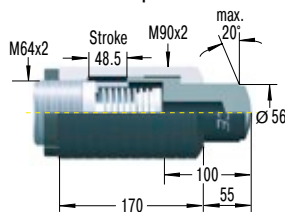

PB6425

Steel Shroud

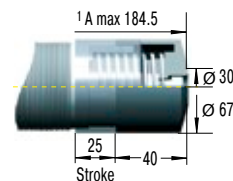

¹ Total installation length of the shock absorber inc. steel shroud

PB6450

Steel Shroud

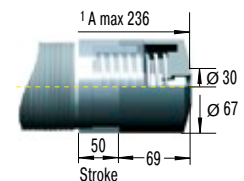

¹ Total installation length of the shock absorber inc. steel shroud

Mounting, installation, ... see page 77.

BV

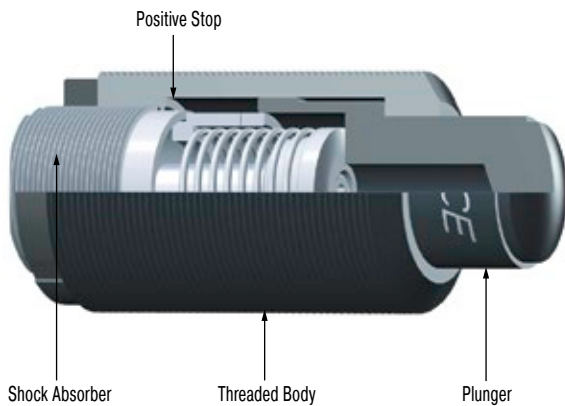

Side Load Adaptor

For side load impact angles from 3° to 25°

With side load impact angles of more than 3° the operation lifetime of the shock absorber reduces rapidly due to increased wear of rod bearings. The optional BV side load adaptor provides long lasting solution.

Ordering information

- BV3325** (M45x1.5) for MC, MA, ML3325EUM (M33x1.5)
- BV3350** (M45x1.5) for MC, MA, ML3350EUM (M33x1.5)
- BV4525** (M64x2) for MC, MA, ML4525EUM (M45x1.5)
- BV4550** (M64x2) for MC, MA, ML4550EUM (M45x1.5)
- BV6425** (M90x2) for ML6425EUM (M64x2)
- BV6450** (M90x2) for MC, MA, ML6450EUM (M64x2)

Material

Threaded body and plunger: Hardened high tensile steel, hardened 610 HV1

Mounting information

Directly mount the shock absorber/side mount assembly on the outside thread of the side load adaptor or by using the QF flange. You cannot use a foot mount.

Calculation example and installation hints see page 45.

PB

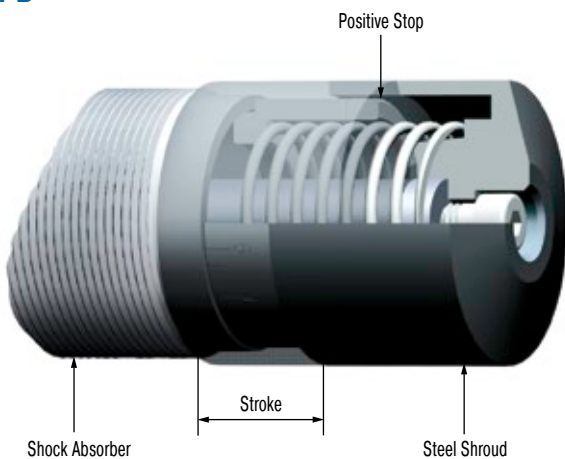

Steel Shroud

For thread sizes M33x1.5, M45x1.5 and M64x2 with 25 or 50 mm stroke.

Grinding beads, sand, welding splatter, paints and adhesives etc. can adhere to the piston rod. They then damage the rod seals and the shock absorber quickly fails. In many cases the installation of the optional steel shroud can provide worthwhile protection and increase lifetime.

Material

Hardened high tensile steel

Mounting information

To mount the PB steel shroud it is necessary to remove the rod end button of the shock absorber.

Safety instructions

When installing don't forget to allow operating space for the shroud to move as the shock absorber is cycled.

AS

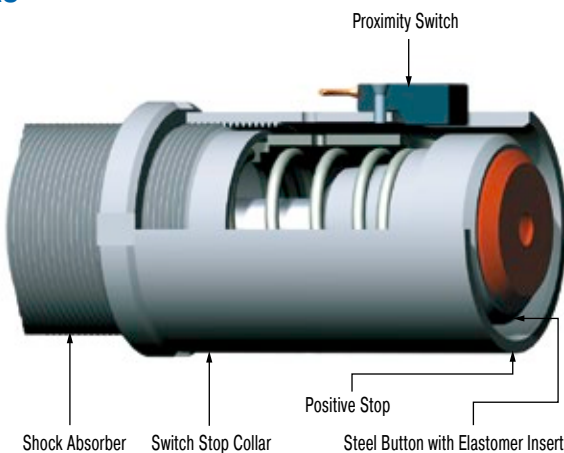

Switch Stop Collar

For thread sizes M33x1.5 and M45x1.5

The ACE stop light switch stop collar combination serves as a safety element to provide stroke position information for automatically sequenced machines. The compact construction allows its use in nearly any application. The standard rod button is detected by the proximity switch at the end of its stroke to provide switch actuation. The switch is normally open when the shock absorber is extended and only closes when it has completed its operating stroke.

Material

Hardened high tensile steel

Delivery

The AS switch stop collar combination is only delivered ready mounted onto the shock absorber c/w the switch.

For circuit diagram of proximity switch see page 46.

Application Examples

MC33EUM

Quicker, gentle positioning

ACE industrial shock absorbers optimize portal for machine loading and increase productivity. This device driven by piston rodless pneumatic cylinders, in which two gripper slides are moving independently of each other at speeds of 2 to 2.5 m/sec., is equipped with industrial shock absorbers as brake systems. Their function is to stop a mass of 25 kg up to 540 times per hour. The model MC3350EUM-1-S was chosen for this application, allowing easy and extremely accurate adjustment of the end positions of the adjustable limit stops. In comparison to brake systems with other function principles, shock absorbers allow higher travel speeds and shorter cycle sequences.

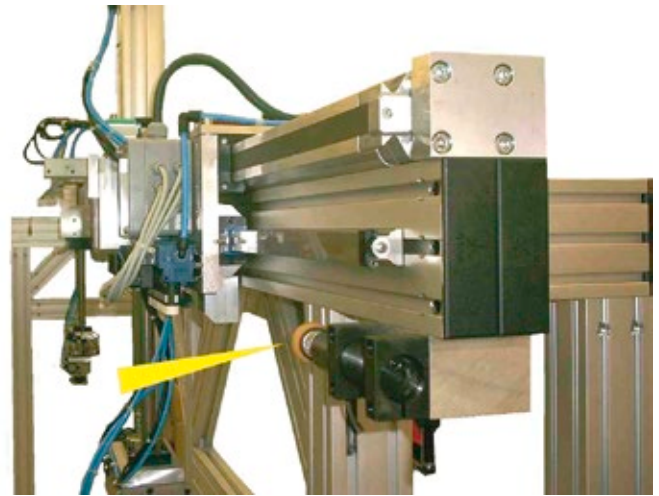
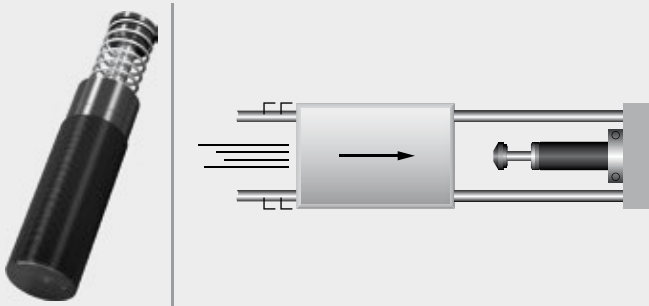

Industrial shock absorbers optimize portal operation

MC45EUM

MAGNUM protection of carriage construction

Serving a similar purpose, several ACE dampers are installed in Jada, the triple-axis, free-moving badminton robot. In order for the badminton robot to be capable of playing, it must be able to change direction in the shortest time possible. Jada is designed therefore to brake at a maximum of 30 m/s². For this task, linear modules are limited by the use of industrial shock absorbers of the type MC4575EUM-0. Miniature shock absorbers and profile dampers are also installed at the location of the "racket hand". In all cases, the modern ACE machine elements serve to protect the end positions of the construction.

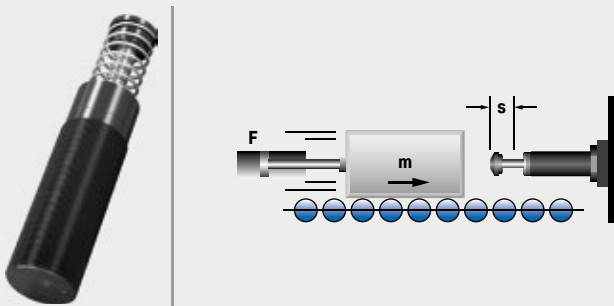

A variety of different dampers are used to slow the rapid movements of a badminton robot
FMTC vzw, 3001 Leuven, Belgium

MC64EUM-VA

MAGNUM Damper for Safety under Water

A pipeline from the rig to the well head that is as flexible as possible is considered to be a quick-disconnect connection in an emergency. Nevertheless, this connection made at the oil source on the sea floor is an Achilles heel. If the connection snaps or if it cannot be separated quickly enough during hazards such as storms, unpredictable, often serious consequences can hardly be prevented. With the so-called XR connector, the safety at this critical point is significantly increased. In the innovative design 10 industrial shock absorbers per connection from the MAGNUM series from ACE in Langenfeld master this important task.

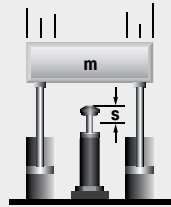

MAGNUMS allow for emergency quick disconnection of the pipelines from the oil rigs
Subsea Technologies Ltd, Aberdeen, AB12 3AY, UK

MA/ML33EUM

Safe swiveling

ACE industrial shock absorbers offer safety to spare for swiveling or braking of large telescope. The optical system of this telescope for special observations is moveable in two space coordinates. The structure in which the telescope is mounted weighs 15,000 kg and consists of a turntable with drives and two wheel disks rotating on bearings. It enables a rotation by $\pm 90^\circ$ from horizon to horizon. To safeguard the telescope in case of overshooting the respective swiveling limits, industrial shock absorbers of the type ML3325EUM are used as braking elements. Should the telescope inadvertently overshoot the permissible swivel range, they will safely damp the travel of the valuable telescope.

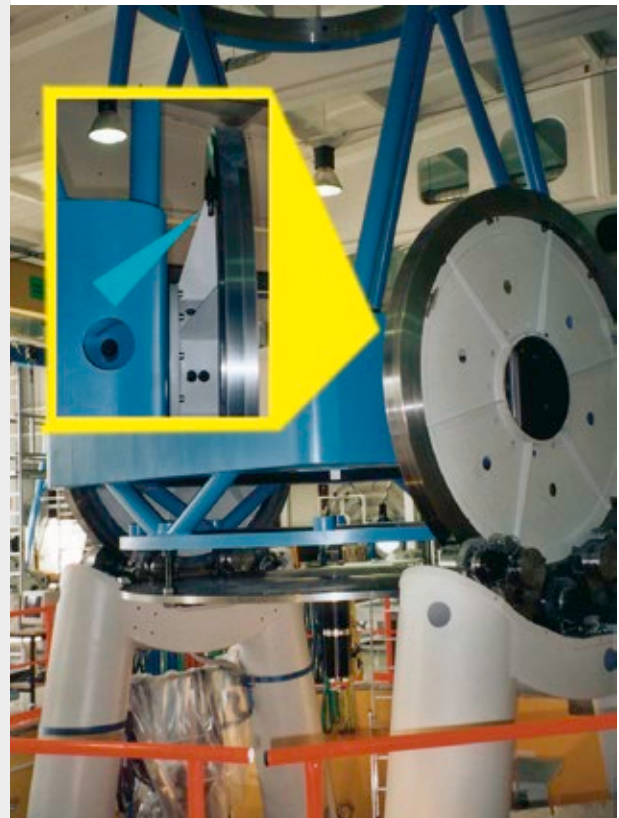
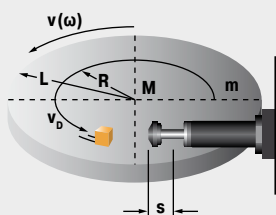

Perfect overshoot protection for precision telescope