

LOCKED PN Clamping Elements

Rod clamping with maximum clamping force

Immediate clamping in case of loss of pneumatics: Suitable for rods with diameters of 20 to 40 mm, the clamping elements from the LOCKED-Series PN absorb the forces axially and rotationally. With holding forces of up to 36,000 N, they reach or exceed the levels of hydraulic clamps. The system costs are however lower.

Alongside clamping in both directions of motion, the LOCKED-PN also surprises with its compact design. They need less installation space and enable short rod lengths. For versions with ISO pneumatic cylinders, the base plate is coordinated to the dimensions of the flange sizes of standard cylinders according to ISO 15552. Users appreciate the modular system. It allows several segments to be stacked so that the necessary clamping force can be attained for every application.

The areas of application for the LOCKED-Series PN are mechanical engineering and machine tools.

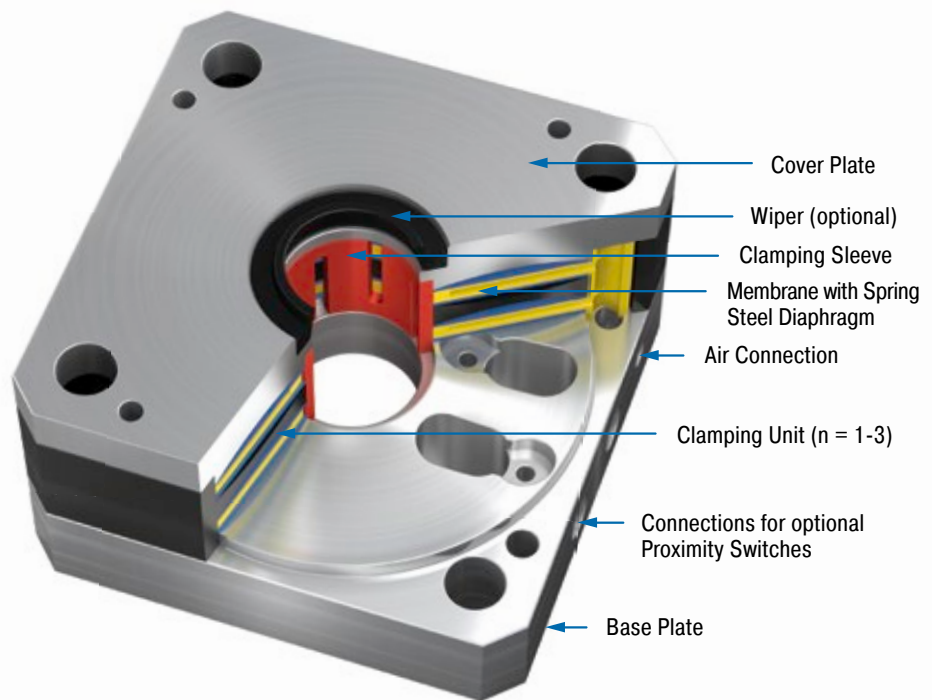

Technical Data

Holding torques: 15 Nm to 720 Nm

Holding forces: 1,400 N to 36,000 N

Rod diameter: Ø 20 mm to Ø 40 mm

Clamping cycles: 1,000,000. Higher values on request.

Mounting: In any position

Operating pressure: 4 bar (automotive) or 6 bar

Material: Outer body: Tool steel

Pneumatic medium: Dried, filtered air

Operating temperature range: 10 °C to 45 °C

Application field: Jacking systems, Light presses, Punching/stamping machines, Stacking units

Note: When mounting, use hardened piston rod.

On request: Special designs as for example special diameters and accessories available on request.

PN

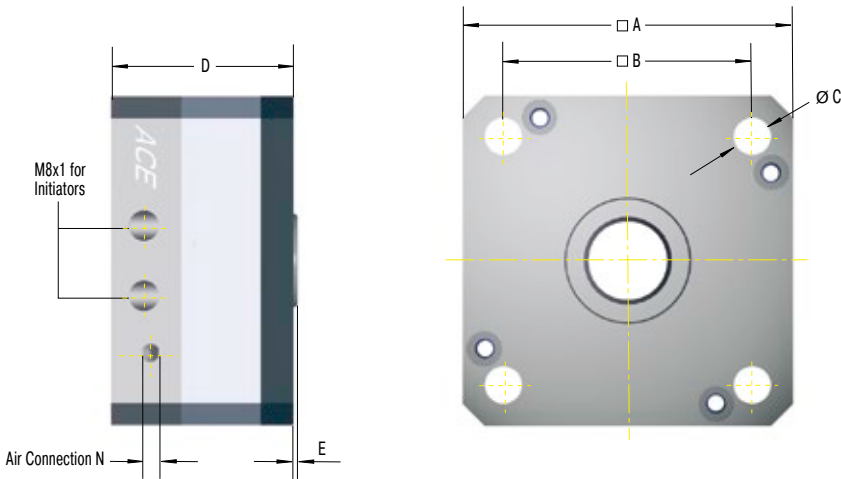

The calculation and selection of the most suitable clamping element should be carried out or be approved by ACE.

Ordering Example

Rod Clamping Standard Model _____
 Cylinder Nominal Diameter 80 mm _____
 Rod Diameter 25 mm _____
 Number of Clamping Units 3 _____
 6B = 6 bar Type _____
 4B = 4 bar Type _____

PN80-25-3-4B

Performance and Dimensions

TYPES	¹ Holding force N	Holding torque Nm	Operating pressure bar	A mm	B mm	C mm	D mm	E mm	N	Weight kg
PN63-20-1-4B	1,400	15	4	75	56.5	8.5	41.5	2.1	M5	0.70
PN63-20-1-6B	2,000	20	6	75	56.5	8.5	41.5	2.1	M5	0.70
PN63-20-2-4B	2,520	25	4	75	56.5	8.5	59.5	2.1	M5	1.13
PN63-20-2-6B	3,600	35	6	75	56.5	8.5	59.5	2.1	M5	1.13
PN63-20-3-4B	3,780	35	4	75	56.5	8.5	77.5	2.1	M5	1.56
PN63-20-3-6B	5,400	50	6	75	56.5	8.5	77.5	2.1	M5	1.56
PN80-25-1-4B	2,100	25	4	96	72	10.5	43.5	2.14	G1/8	1.30
PN80-25-1-6B	3,000	35	6	96	72	10.5	43.5	2.14	G1/8	1.30
PN80-25-2-4B	3,780	40	4	96	72	10.5	63.5	2.14	G1/8	2.20
PN80-25-2-6B	5,400	60	6	96	72	10.5	63.5	2.14	G1/8	2.20
PN80-25-3-4B	5,670	65	4	96	72	10.5	83.5	2.14	G1/8	3.10
PN80-25-3-6B	8,100	95	6	96	72	10.5	83.5	2.14	G1/8	3.10
PN125-40-1-4B	7,000	140	4	145	110	13	51.6	3	G1/8	3.65
PN125-40-1-6B	10,000	200	6	145	110	13	51.6	3	G1/8	3.65
PN125-40-2-4B	12,600	250	4	145	110	13	75.2	3	G1/8	5.85
PN125-40-2-6B	18,000	360	6	145	110	13	75.2	3	G1/8	5.85
PN125-40-3-4B	18,900	375	4	145	110	13	98.8	3	G1/8	8.05
PN125-40-3-6B	27,000	540	6	145	110	13	98.8	3	G1/8	8.05
PN125-40-4-4B	25,200	500	4	145	110	13	122.4	3	G1/8	10.25
PN125-40-4-6B	36,000	720	6	145	110	13	122.4	3	G1/8	10.25

¹ The listed holding forces are reached under optimum conditions. We recommend a safety factor of > 10 %. Please note that surface, material and cleanliness of the rod as well as wear and tear and the use of rod wipers lead to different holding forces. Test the clamping needed for series production or safety applications in its specific application environment and measure the actual values.

LOCKED PRK Clamping Elements

Rod clamping with maximum clamping force in a compact size

Compact and safe: when space becomes restricted, the compact clamping elements from the LOCKED-Series PRK come into their own. As pneumatic rod clamping with low heights of 28 to 34 mm, they provide clamping forces of up to 5,000 N.

Clamping is carried out by a diaphragm spring-plate system and is released when compressed air is applied. Clamping elements from the LOCKED-Series PRK absorb the forces on rods with diameters between 20 and 40 mm both axially and rotationally. The function makes them suitable for use as static clamping without pressure, because the failure or drop of pneumatic pressure triggers immediate clamping. High clamping forces with low system costs compared with hydraulic and electric solutions make these clamping elements particularly interesting.

Models from the LOCKED-Series PRK are used in mechanical engineering and customised machine tools.

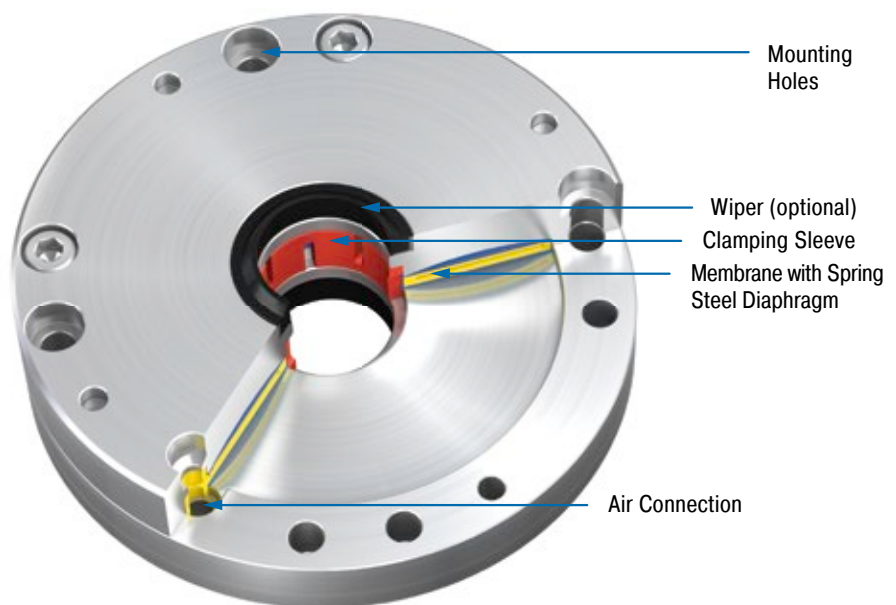

Technical Data

Holding torques: 7 Nm to 100 Nm

Holding forces: 700 N to 5,000 N

Rod diameter: Ø 20 mm to Ø 40 mm

Clamping cycles: 1,000,000. Higher values on request.

Mounting: In any position

Operating pressure: 4 bar (automotive) or 6 bar

Material: Outer body: Tool steel

Pneumatic medium: Dried, filtered air

Operating temperature range: 10 °C to 45 °C

Application field: Jacking systems, Light presses, Punching/stamping machines, Stacking units

Note: When mounting, use hardened piston rod.

On request: Special designs as for example special diameters and accessories available on request.

PRK

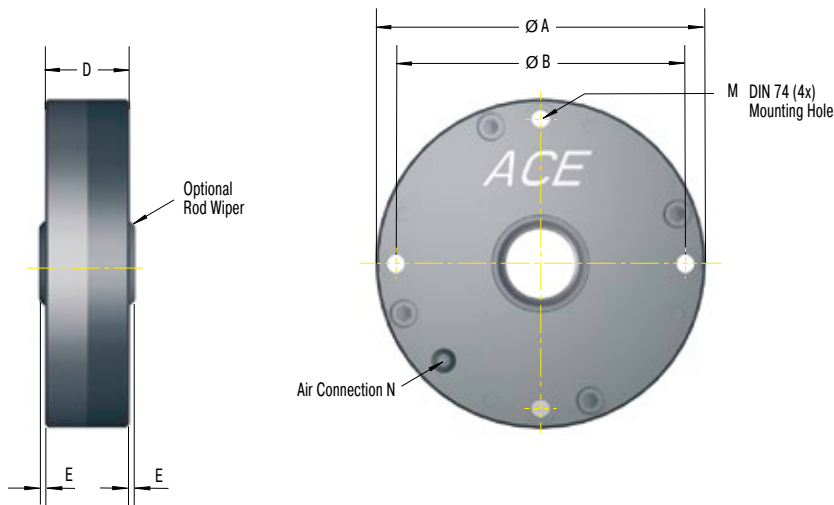

The calculation and selection of the most suitable clamping element should be carried out or be approved by ACE.

Complete details required when ordering

Operating pressure: 4 bar or 6 bar

Ordering Example

PRK80-25-6B

Rod Clamping Compact _____
 Cylinder Nominal Diameter 80 mm _____
 Rod Diameter 25 mm _____
 6B = 6 bar Type _____
 4B = 4 bar Type _____

Performance and Dimensions

TYPES	¹ Holding force N	Holding torque Nm	Operating pressure bar	A mm	B mm	D mm	E mm	M	N	Weight kg
PRK63-20-4B	700	7	4	92	80	28	2.1	M5	G1/8	1.15
PRK63-20-6B	1,000	10	6	92	80	28	2.1	M5	G1/8	1.15
PRK80-25-4B	1,050	12	4	118	104	29	2.14	M6	G1/8	2.10
PRK80-25-6B	1,500	17	6	118	104	29	2.14	M6	G1/8	2.10
PRK125-40-4B	3,500	70	4	168	152	29	3	M6	G1/8	4.90
PRK125-40-6B	5,000	100	6	168	152	29	3	M6	G1/8	4.90

¹ The listed holding forces are reached under optimum conditions. We recommend a safety factor of > 10 %. Please note that surface, material and cleanliness of the rod as well as wear and tear and the use of rod wipers lead to different holding forces. Test the clamping needed for series production or safety applications in its specific application environment and measure the actual values.