

HT Series

Cylinders with tie-rods / ISO 6020/2 - 160 bar



Technical characteristics

Standard	ISO 6020/2																				
Construction type	With tie-rods																				
Rated pressure	160 bar																				
Test pressure	240 bar																				
Ambient temperature	-20°C → +80°C																				
	-20°C → +160°C with Viton seals																				
Fluid temperature	-20°C → +80°C																				
	-20°C → +160°C with Viton seals																				
Fluid	Mineral oil - Other fluids on demand																				
Piston (mm)	25		32		40		50		63		80		100		125		160		200		
Rod (mm)	12	18	14	22	18	28	22	36	28	45	36	56	45	70	56	90	70	110	90	140	
Maximum speed (m/s) standard seals	0,5							0,4													
Maximum speed (m/s) low-friction seals	1																				

HT Series

Cylinders with tie-rods / ISO 6020/2 - 160 bar

Codification

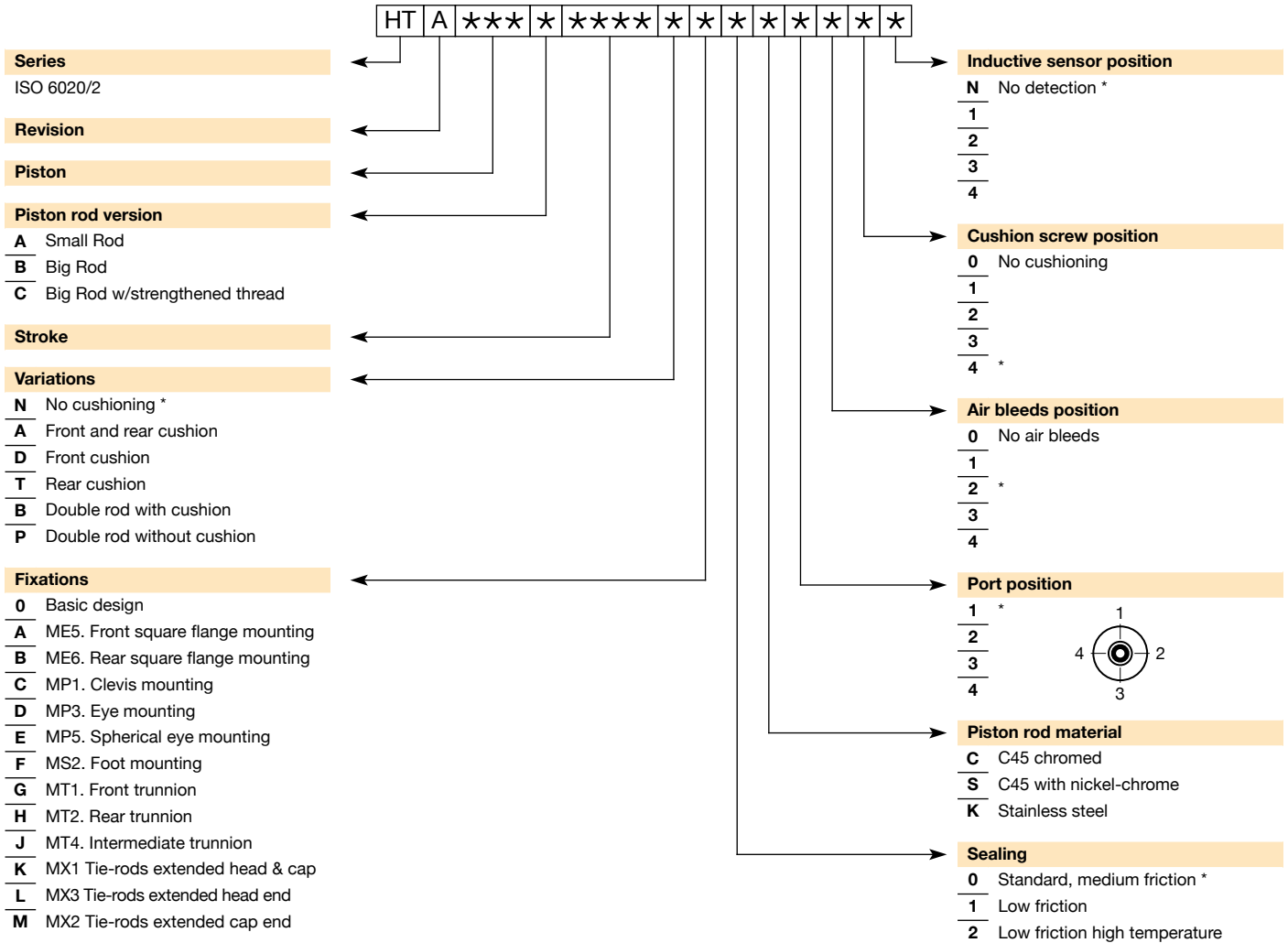

A spacer is installed for strokes higher than 1000 mm
 Overall length of the cylinder increases this way:
 1001 - 1500: +50mm total length
 1501 - 2000: +100mm total length
 2001 - 2500: +150mm total length
 2501 - 3000: +200mm total length

*Default option

HT Series ISO 6020/2 Hydraulic Cylinders

Basic model

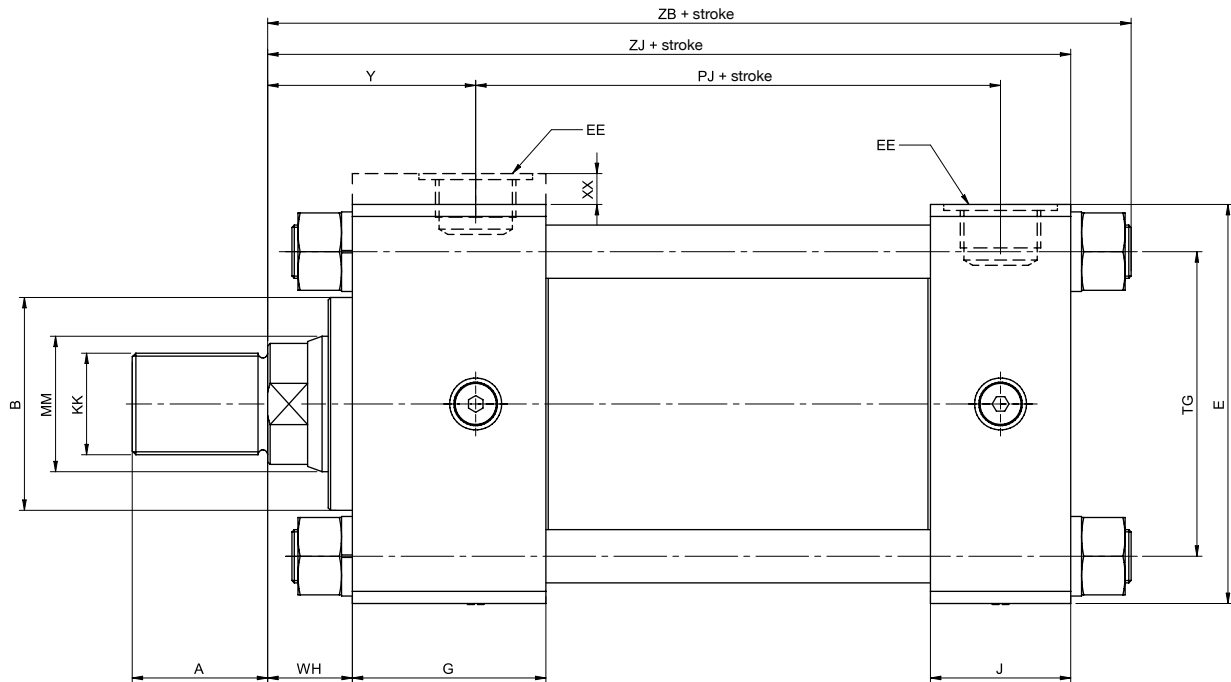

Ø	ØMM	A	B ¹⁹ Ø	XX	E	EE	G	J	KK	PJ	TG	WH	Y	ZB	ZJ
25	12	14	24						M10x1,25						
	18	14	30	5	40	1/4"G	50	25	M10x1,25 M14x1,5	54	28,3	15	50	121	114
32	14	16	26						M12x1,5						
	22	16	34	5	45	1/4"G	50	25	M12x1,5 M16x1,5	57	33,2	25	60	137	128
	22	22	34						M16x1,5						
40	18	18	30						M14x1,5						
	28	18	42	-	63	3/8"G	55	38	M14x1,5 M20x1,5	74	41,7	25	62	166	153
50	22	22	34						M16x1,5						
	36	22	50	-	75	1/2"G	60	38	M16x1,5 M27x2	76	52,3	26	68	176	159
63	28	28	42						M20x1,5						
	45	28	60	-	90	1/2"G	60	38	M20x1,5 M33x2	80	64,3	33	71	185	168
80	36	36	50						M27x2						
	56	36	72	-	115	3/4"G	70	45	M27x2 M42x2	93	82,7	31	77	212	190
100	45	45	60						M33x2						
	70	45	88	-	130	3/4"G	72	45	M33x2 M48x2	101	96,9	35	82	225	203
125	56	56	72						M42x2						
	90	56	108	-	165	1"G	80	58	M42x2 M64x3	117	125,9	35	86	260	232
160	70	63	88						M48x2						
	110	63	133	-	205	1"G	83	58	M48x2 M80x3	130	154,9	32	86	279	245
200	90	85	108						M64x3						
	140	85	163	-	245	1 1/4"G	101	76	M64x3 M100x3	165	190,2	32	98	336	299

HT Series

ISO 6020/2 Hydraulic Cylinders

Seal kit

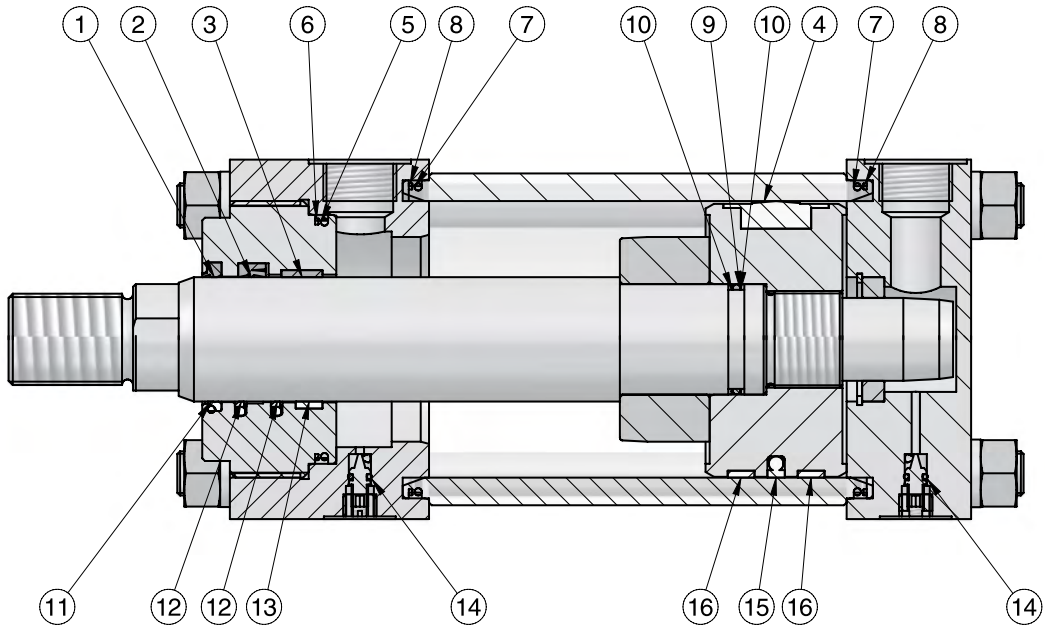

Position	Description
1	Wiper
2	Rod seal
3	Piston-rod guide ring
4	Piston seal
5	O-ring
6	Anti-extrusion seal
7	O-ring
8	Anti-extrusion seal
9	O-ring
10	Anti-extrusion seal
11	Wiper (low friction)
12	Rod seal (LF)
13	Piston-rod guide band (LF)
14	O-ring
15	Piston ring (LF)
16	Piston-rod guide band (LF)

ISO 6020/2 Serie	Piston	Rod	Seal type
	025 = 25 mm	014 = 14 mm	0 = Standard, medium friction
	032 = 32 mm	018 = 18 mm	1 = Low friction
	040 = 40 mm	022 = 22 mm	2 = Low friction, high temperature
	050 = 50 mm	028 = 28 mm	
	063 = 63 mm	036 = 36 mm	
	080 = 80 mm	045 = 45 mm	
	100 = 100 mm	056 = 56 mm	
	125 = 125 mm	070 = 70 mm	
	160 = 160 mm	090 = 90 mm	
	200 = 200 mm	110 = 110 mm	
		140 = 140 mm	

HT Series

ISO 6020/2 Hydraulic Cylinders

Fixing accessories

Front rectangular flange mounting ISO ME5

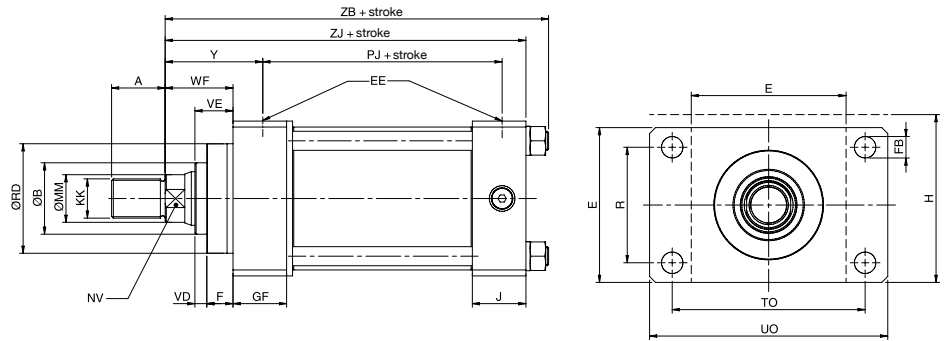
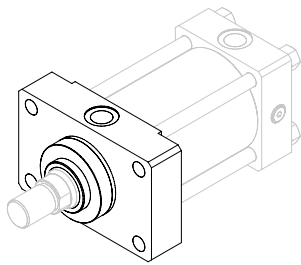

Ø	ØMM	A	B	E	EE	F	FB	GF	H	J	KK	NV	PJ	R	RD	TO	UO	VD	VE	WF	Y	ZB	ZJ
25	12	14	24								M10x1,25	10											
	18	14	30	40	1/4"G	10	5,5	25	45	25	M10x1,25	15	53	27	38	51	65	6	16	25	50	121	114
32	14	16	26								M14x1,5	12											
	22	16	34	45	1/4"G	10	6,6	25	50	25	M12x1,5	18	56	33	42	58	70	12	22	35	60	136	128
		22									M16x1,5	15											
40	18	18	30								M14x1,5	15											
	28	18	42	63	3/8"G	10	11	38		38	M14x1,5	22	73	41	62	87	110	12	22	35	62	163	153
		28									M20x1,5	18											
50	22	22	34								M16x1,5	18											
	36	22	50	75	1/2"G	16	14	38		38	M16x1,5	30	74	52	74	105	130	9	25	41	67	173	159
		36									M27x2	22											
63	28	28	42								M20x1,5	22			75								
	45	28	60	90	1/2"G	16	14	38		38	M20x1,5	36	80	65	88	117	145	13	29	48	71	182	168
		45									M33x2	30											
80	36	36	50								M27x2	30			82								
	56	36	72	115	3/4"G	20	18	45		45	M27x2	46	93	83	105	149	180	9	29	51	77	209	190
		56									M42x2	36											
100	45	45	60								M33x2	36			92								
	70	45	88	130	3/4"G	22	18	45		45	M33x2	60	101	97	125	162	200	10	32	57	82	222	203
		63									M48x2	46											
125	56	56	72								M42x2	46			105								
	90	56	108	165	1"G	22	22	58		58	M42x2	80	117	126	150	208	250	10	32	57	86	257	232
		85									M64x3	60											
160	70	63	88								M48x2	60			125								
	110	63	133	205	1"G	25	26	58		58	M48x2	100	130	155	170	253	300	7	32	57	86	277	245
		95									M80x3	80											
200	90	85	108								M64x3	80			150								
	140	85	163	245	1 1/4"G	25	33	76		76	M64x3	120	165	190	210	300	360	7	32	57	98	334	299
		112									M100x3												

HT Series

ISO 6020/2 Hydraulic Cylinders

Fixing accessories

Rear rectangular flange mounting ISO ME6

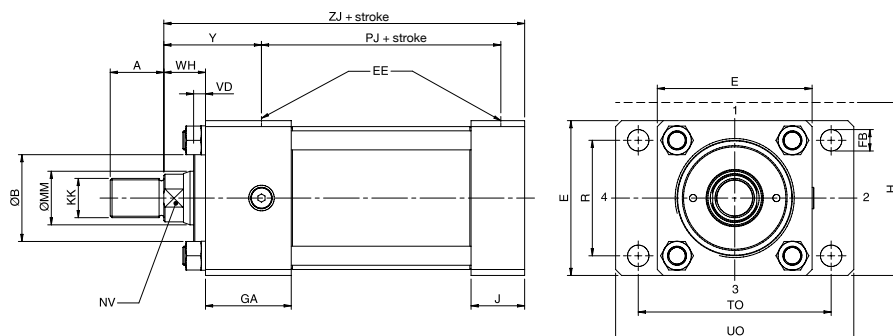
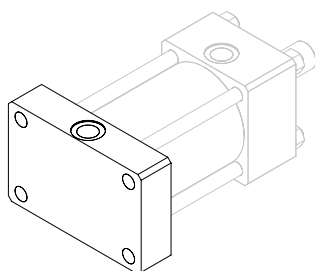

Ø	ØMM	A	B	E	EE	FB	GA	H	J	KK	NV	PJ	R	TO	UO	VD	WH	Y	ZJ
25	12	14	24	40	1/4"G	5,5	50	45	25	M10x1,25	10	53	27	51	65	6	15	50	114
	18	30	M10x1,25							15									
32	14	16	26	45	1/4"G	6,6	50	50	25	M12x1,5	12	56	33	58	70	12	25	60	128
	16	34	M12x1,5							18									
	22	34	M16x1,5							18									
40	18	18	30	63	3/8"G	11	55	38	38	M14x1,5	15	73	41	87	110	12	25	62	153
	28	42	M14x1,5							22									
	22	34	M20x1,5							22									
50	22	22	34	75	1/2"G	14	61	38	38	M16x1,5	18	74	52	105	130	9	25	67	159
	36	50	M16x1,5							30									
	36	50	M27x2							30									
63	28	28	42	90	1/2"G	14	61	38	38	M20x1,5	22	80	65	117	145	13	32	71	168
	45	60	M20x1,5							36									
	45	60	M33x2							36									
80	36	36	50	115	3/4"G	18	70	45	45	M27x2	30	93	83	149	180	9	31	77	190
	56	72	M27x2							46									
	56	72	M42x2							46									
100	45	45	60	130	3/4"G	18	72	45	45	M33x2	36	101	97	162	200	10	35	82	203
	70	88	M33x2							60									
	63	88	M48x2							60									
125	56	56	72	165	1"G	22	80	58	58	M42x2	46	117	126	208	250	10	35	86	232
	90	108	M42x2							80									
	85	108	M64x3							80									
160	70	63	88	205	1"G	26	83	58	58	M48x2	60	130	155	253	300	7	32	86	245
	110	133	M48x2							100									
	95	133	M80x3							100									
200	90	85	108	245	1 1/4"G	33	101	76	76	M64x3	80	165	190	300	360	7	32	98	299
	85	163	M64x3							80									
	140	163	M100x3							120									

HT Series

ISO 6020/2 Hydraulic Cylinders

Fixing accessories

Clevis mounting ISO MP1

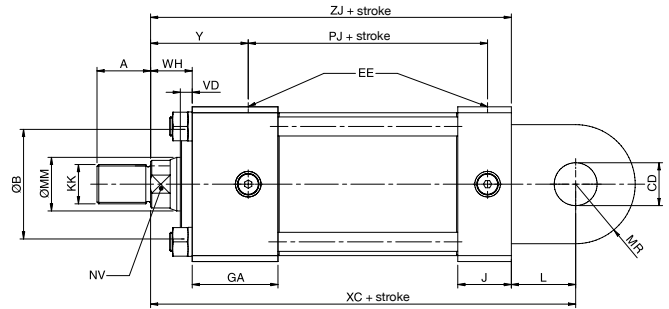
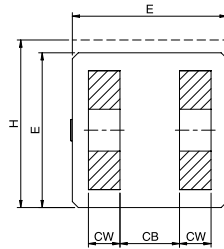
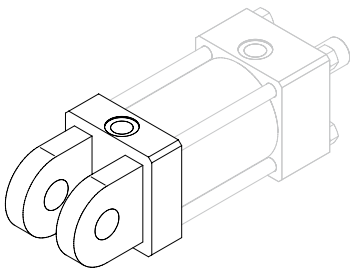

Ø	ØMM	A	B	CB	CD	CW	E	EE	GA	H	J	KK	L	MR	NV	PJ	VD	WH	XC	Y	ZJ
25	12	14	24	12	10	6	40	1/4"G	50	45	25	M10x1,25	13	12	10	53	6	15	127	50	114
	18	14	30									M10x1,25									
32	14	16	26	16	12	8	45	1/4"G	50	50	25	M12x1,5	19	17	12	56	12	25	147	60	128
	22	16	34									M12x1,5									
	22	18	30									M16x1,5									
40	18	18	30	20	14	10	63	3/8"G	55	38	38	M14x1,5	19	17	15	73	12	25	172	62	153
	28	18	42									M14x1,5									
	28	28	34									M20x1,5									
50	22	22	34	30	20	15	75	1/2"G	61	38	38	M16x1,5	32	29	18	74	9	25	191	67	159
	36	22	50									M16x1,5									
	36	36	50									M27x2									
63	28	28	42	30	20	15	90	1/2"G	61	38	38	M20x1,5	32	29	22	80	13	32	200	71	168
	45	28	60									M20x1,5									
	45	45	60									M33x2									
80	36	36	50	40	28	20	115	3/4"G	70	45	45	M27x2	39	34	30	93	9	31	229	77	190
	56	36	72									M27x2									
	56	56	72									M42x2									
100	45	45	60	50	36	25	130	3/4"G	72	45	45	M33x2	54	44	36	101	10	35	257	82	203
	70	45	88									M33x2									
	63	56	72									M48x2									
125	56	56	72	60	45	30	165	1"G	80	58	58	M42x2	57	53	46	117	10	35	289	86	232
	90	56	108									M42x2									
	85	85	108									M64x3									
160	70	63	88	70	56	35	205	1"G	83	58	58	M48x2	63	59	60	130	7	32	308	86	245
	110	63	133									M48x2									
	95	85	108									M80x3									
200	90	85	108	80	70	40	245	1 1/4"G	101	76	76	M64x3	82	78	80	165	7	32	381	98	299
	85	85	163									M64x3									
	140	112	163									M100x3									

HT Series

ISO 6020/2 Hydraulic Cylinders

Fixing accessories

Eye mounting ISO MP3

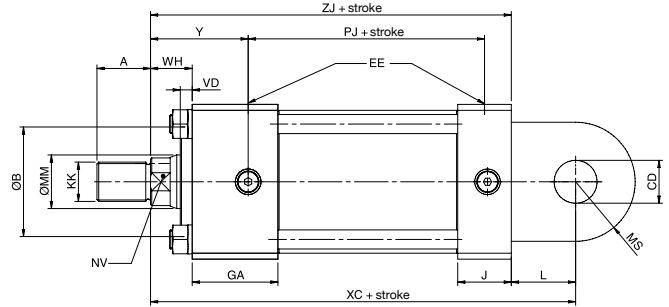
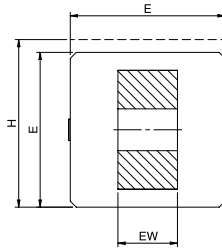
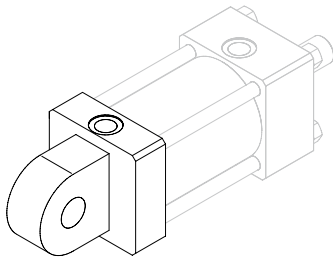

Ø	ØMM	A	B	CD	E	EE	EW	GA	H	J	KK	L	MS	NV	PJ	VD	WH	XC	Y	ZJ
25	12	14	24	10	40	1/4"G	12	50	45	25	M10x1,25	13	12	10	53	6	15	127	50	114
	18	30	M10x1,25								15									
32	14	16	26	12	45	1/4"G	16	50	50	25	M12x1,5	19	17	12	56	12	25	147	60	128
	22	34	M12x1,5								18									
	22	34	M16x1,5								18									
40	18	18	30	14	63	3/8"G	20	55	38	38	M14x1,5	19	17	15	73	12	25	172	62	153
	28	42	M14x1,5								22									
50	22	22	34	20	75	1/2"G	30	61	38	38	M16x1,5	32	29	18	74	9	25	191	67	159
	36	50	M16x1,5								30									
	36	50	M27x2								30									
63	28	28	42	20	90	1/2"G	30	61	38	38	M20x1,5	32	29	22	80	13	32	200	71	168
	45	60	M20x1,5								36									
	45	60	M33x2								36									
80	36	36	50	28	115	3/4"G	40	70	45	45	M27x2	39	34	30	93	9	31	229	77	190
	56	72	M27x2								46									
	56	72	M42x2								46									
100	45	45	60	36	130	3/4"G	50	72	45	45	M33x2	54	44	36	101	10	35	257	82	203
	70	88	M33x2								60									
	63	88	M48x2								60									
125	56	56	72	45	165	1"G	60	80	58	58	M42x2	57	53	46	117	10	35	289	86	232
	90	108	M42x2								80									
	85	108	M64x3								80									
160	70	63	88	56	205	1"G	70	83	58	58	M48x2	63	59	60	130	7	32	308	86	245
	110	133	M48x2								100									
	95	133	M80x3								100									
200	90	85	108	70	245	1 1/4"G	80	101	76	76	M64x3	82	78	80	165	7	32	381	98	299
	85	163	M64x3								80									
	140	163	M100x3								120									

HT Series

ISO 6020/2 Hydraulic Cylinders

Fixing accessories

Spherical eye mounting ISO MP5

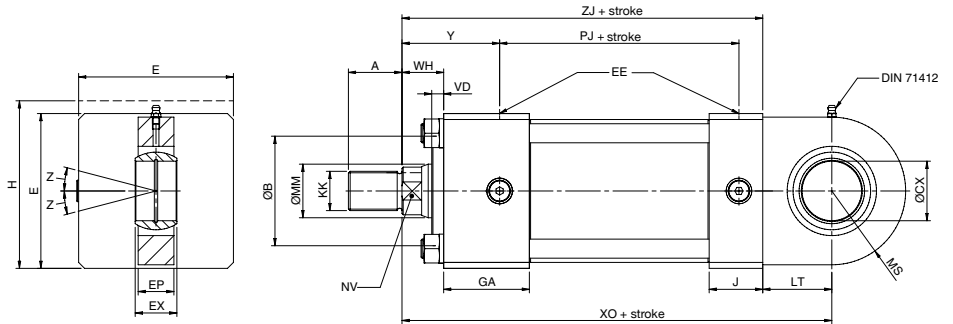
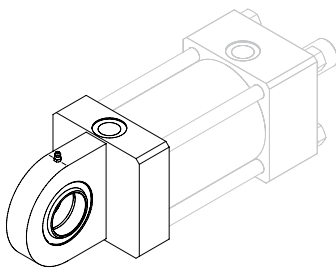

Ø	ØMM	A	B	CX	E	EE	EP	EX	GA	H	J	KK	LT	MS	NV	PJ	VD	WH	XO	Y	Z	ZJ
25	12	14	24	12	40	1/4"G	8	10	50	45	25	M10x1,25	16	20	10	53	6	15	130	50	4°	114
	18	14	30									M10x1,25										
32	14	16	26	16	45	1/4"G	11	14	50	50	25	M12x1,5	20	22,5	12	56	12	25	148	60	4°	128
	22	16	34									M12x1,5										
40	18	18	30	20	63	3/8"G	13	16	55		38	M14x1,5	25	29	15	73	12	25	178	62	4°	153
	28	18	42									M14x1,5										
50	22	22	34	25	75	1/2"G	17	20	61		38	M16x1,5	31	33	18	74	9	25	190	67	4°	159
	36	22	50									M16x1,5										
63	28	28	42	30	90	1/2"G	19	22	61		38	M20x1,5	38	40	22	80	13	32	206	71	4°	168
	45	28	60									M20x1,5										
80	36	36	50	40	115	3/4"G	23	28	70		45	M27x2	48	50	30	93	9	31	238	77	4°	190
	56	36	72									M27x2										
100	45	45	60	50	130	3/4"G	30	35	72		45	M33x2	58	62	36	101	10	35	261	82	4°	203
	70	45	88									M33x2										
125	56	56	72	60	165	1"G	38	44	80		58	M42x2	72	80	46	117	10	35	304	86	4°	232
	90	56	108									M42x2										
160	70	63	88	80	205	1"G	47	55	83		58	M48x2	92	100	60	130	7	32	337	86	4°	245
	110	63	133									M48x2										
200	90	85	108	100	245	1 1/4"G	57	70	101		76	M64x3	116	120	80	165	7	32	415	98	4°	299
	140	85	163									M64x3										
		112																				

HT Series

ISO 6020/2 Hydraulic Cylinders

Fixing accessories

Foot mounting ISO MS2

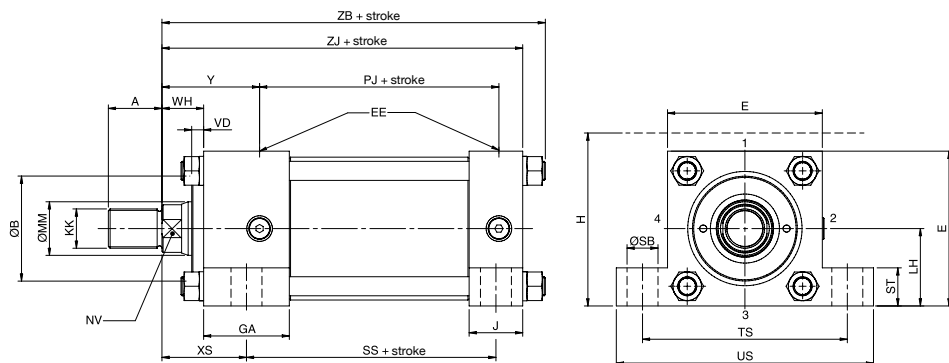
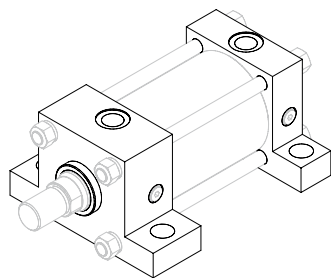

Ø	ØMM	A	B	E	EE	GA	H	J	KK	LH	NV	PJ	SB	SS	ST	TS	US	VD	WH	XS	Y	ZB	ZJ
25	12	14	24	40	1/4"G	50	45	25	M10x1,25	19	10	53	6,6	73	8,5	54	72	6	15	33	50	121	114
	18	14	30						M10x1,25														
32	14	16	26	45	1/4"G	50	50	25	M12x1,5	22	12	56	9	73	12,5	63	84	12	25	45	60	136	128
	22	16	34						M12x1,5														
									M16x1,5														
40	18	18	30	63	3/8"G	55		38	M14x1,5	31	15	73	11	98	12,5	83	103	12	25	45	62	163	153
	28	18	42						M14x1,5														
		28	42						M20x1,5														
50	22	22	34	75	1/2"G	61		38	M16x1,5	37	18	74	14	92	19	102	127	9	25	54	67	173	159
	36	22	50						M16x1,5														
		36	50						M27x2														
63	28	28	42	90	1/2"G	61		38	M20x1,5	44	22	80	18	86	26	124	161	13	32	65	71	182	168
	45	28	60						M20x1,5														
		45	60						M33x2														
80	36	36	50	115	3/4"G	70		45	M27x2	57	30	93	18	105	26	149	186	9	31	68	77	209	190
	56	36	72						M27x2														
		56	72						M42x2														
100	45	45	60	130	3/4"G	72		45	M33x2	63	36	101	26	102	32	172	216	10	35	79	82	222	203
	70	45	88						M33x2														
		63	88						M48x2														
125	56	56	72	165	1"G	80		58	M42x2	82	46	117	26	131	32	210	254	10	35	79	86	257	232
	90	56	108						M42x2														
		85	108						M64x3														
160	70	63	88	205	1"G	83		58	M48x2	101	60	130	33	130	38	260	318	7	32	86	86	277	245
	110	63	133						M48x2														
		95	133						M80x3														
200	90	85	108	245	1 1/4"G	101		76	M64x3	122	80	165	39	172	44	311	381	7	32	92	98	334	299
	140	85	163						M64x3														
		112	163						M100x3														

HT Series

ISO 6020/2 Hydraulic Cylinders

Fixing accessories

Front trunnion ISO MT1

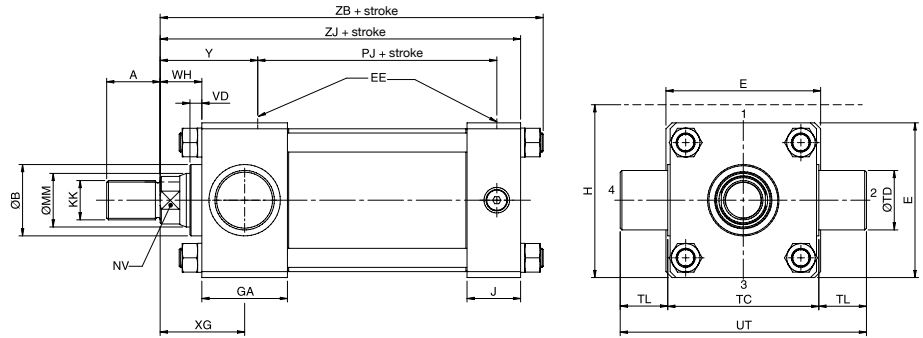
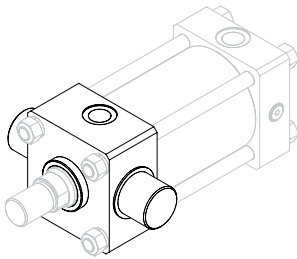

Ø	ØMM	A	B	E	EE	GA	H	J	KK	NV	PJ	TC	TD	TL	UT	VD	WH	XG	Y	ZB	ZJ
25	12	14	24	40	1/4"G	50	45	25	M10x1,25	10	53	38	12	10	58	6	15	44	50	121	114
	18	14	30						M14x1,5	15											
32	14	16	26	45	1/4"G	50	50	25	M12x1,5	12	56	44	16	12	68	12	25	54	60	136	128
	22	16	34						M12x1,5	18											
									M16x1,5	18											
40	18	18	30	63	3/8"G	55		38	M14x1,5	15	73	63	20	16	95	12	25	57	62	163	153
	28	18	42						M14x1,5	22											
		28							M20x1,5	22											
50	22	22	34	75	1/2"G	61		38	M16x1,5	18	74	76	25	20	116	9	25	64	67	173	159
	36	22	50						M16x1,5	30											
		36							M27x2	30											
63	28	28	42	90	1/2"G	61		38	M20x1,5	22	80	89	32	25	139	13	32	70	71	182	168
	45	28	60						M20x1,5	36											
		45							M33x2	36											
80	36	36	50	115	3/4"G	70		45	M27x2	30	93	114	40	32	178	9	31	76	77	209	190
	56	36	72						M27x2	46											
		56							M42x2	46											
100	45	45	60	130	3/4"G	72		45	M33x2	36	101	127	50	40	207	10	35	71	82	222	203
	70	45	88						M33x2	60											
		63							M48x2	60											
125	56	56	72	165	1"G	80		58	M42x2	46	117	165	63	50	265	10	35	75	86	257	232
	90	56	108						M42x2	80											
		85							M64x3	80											
160	70	63	88	205	1"G	83		58	M48x2	60	130	203	80	63	329	7	32	75	86	277	245
	110	63	133						M48x2	100											
		95							M80x3	100											
200	90	85	108	245	1 1/4"G	101		76	M64x3	80	165	241	100	80	401	7	32	85	98	334	299
	140	85	163						M64x3	120											
		112							M100x3	120											

HT Series

ISO 6020/2 Hydraulic Cylinders

Fixing accessories

Rear trunnion ISO MT2

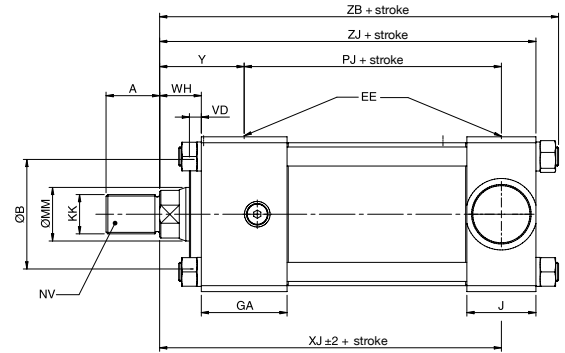
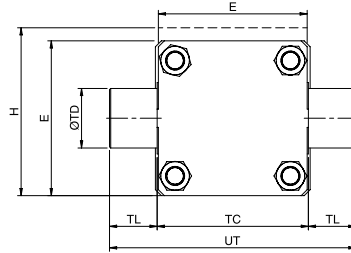
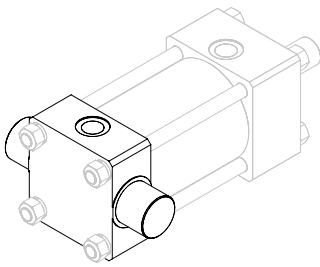

Ø	ØMM	A	B	E	EE	GA	H	J	KK	NV	PJ	TC	TD	TL	UT	VD	WH	XJ	Y	ZB	ZJ
25	12	14	24	40	1/4"G	50	45	25	M10x1,25	10	53	38	12	10	58	6	15	101	50	121	114
	18	14	30						M14x1,5	15											
32	14	16	26	45	1/4"G	50	50	25	M12x1,5	12	56	44	16	12	68	12	25	115	60	136	128
	22	16	34						M12x1,5	18											
40	18	18	30	63	3/8"G	55		38	M14x1,5	15	73	63	20	16	95	12	25	134	62	163	153
	28	18	42						M14x1,5	22											
50	22	22	34	75	1/2"G	61		38	M16x1,5	18	74	76	25	20	116	9	25	140	67	173	159
	36	22	50						M16x1,5	30											
63	28	28	42	90	1/2"G	61		38	M20x1,5	22	80	89	32	25	139	13	32	149	71	182	168
	45	28	60						M20x1,5	36											
80	36	36	50	115	3/4"G	70		45	M27x2	30	93	114	40	32	178	9	31	168	77	209	190
	56	36	72						M27x2	46											
100	45	45	60	130	3/4"G	72		45	M33x2	36	101	127	50	40	207	10	35	187	82	222	203
	70	45	88						M33x2	60											
125	56	56	72	165	1"G	80		58	M42x2	46	117	165	63	50	265	10	35	209	86	257	232
	90	56	108						M42x2	80											
160	70	63	88	205	1"G	83		58	M48x2	60	130	203	80	63	329	7	32	230	86	277	245
	110	63	133						M48x2	100											
200	90	85	108	245	1 1/4"G	101		76	M64x3	80	165	241	100	80	401	7	32	276	98	334	299
	140	85	163						M64x3	120											

HT Series

ISO 6020/2 Hydraulic Cylinders

Fixing accessories

Intermediate trunnion ISO MT4

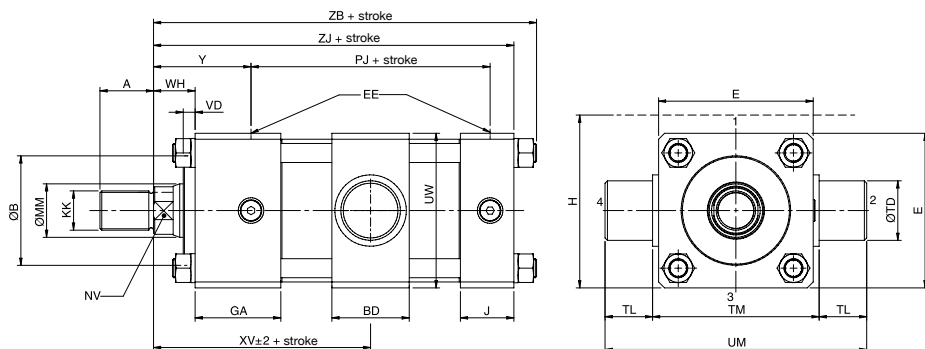
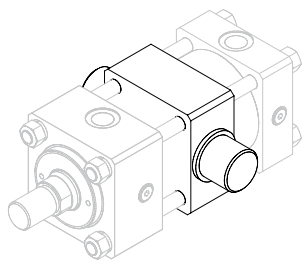

Ø	ØMM	A	B	BD	E	EE	GA	H	J	KK	NV	PJ	TD	TL	TM	UM	UW	VD	WH	XV _(min)	Y	ZB	ZJ	
25	12	14	24	20	40	1/4"G	50	45	25	M10x1,25	10	53	12	10	48	68	45	6	15	77	50	121	114	
	18	14	30							M10x1,25	15													M14x1,5
32	14	16	26	25	45	1/4"G	50	50	25	M12x1,5	12	56	16	12	55	79	50	12	25	90	60	136	128	
	22	16	34							M12x1,5	18													M16x1,5
	22	18	30							M14x1,5	15													
40	18	18	30	30	63	3/8"G	55	38	38	M14x1,5	15	73	20	16	76	108	70	12	25	97	62	163	153	
	28	18	42							M14x1,5	22													M20x1,5
	22	22	34							M16x1,5	18													
50	22	22	34	40	75	1/2"G	61	38	38	M16x1,5	18	74	25	20	89	129	83	9	25	108	67	173	159	
	36	22	50							M16x1,5	30													M27x2
	36	36	50							M20x1,5	22													
63	28	28	42	48	90	1/2"G	61	38	38	M20x1,5	22	80	32	25	100	150	94	13	32	119	71	182	168	
	45	28	60							M33x2	36													M27x2
	45	45	60							M42x2	46													
80	36	36	50	55	115	3/4"G	70	45	45	M27x2	30	93	40	32	127	191	118	9	31	131	77	209	190	
	56	36	72							M42x2	46													M33x2
	56	56	72							M42x2	46													
100	45	45	60	65	130	3/4"G	72	45	45	M33x2	36	101	50	40	140	220	128	10	35	142	82	222	203	
	70	45	88							M48x2	60													M42x2
	63	56	72							M42x2	46													
125	56	56	72	85	165	1"G	80	58	58	M42x2	46	117	63	50	178	278	168	10	35	160	86	257	232	
	90	56	108							M64x3	80													M48x2
	85	63	88							M48x2	60													
160	70	63	88	105	205	1"G	83	58	58	M48x2	60	130	80	63	215	341	205	7	32	170	86	277	245	
	110	63	133							M80x3	100													M64x3
	95	85	108							M64x3	80													
200	90	85	108	125	245	1 1/4"G	101	76	76	M64x3	80	165	100	80	279	439	250	7	32	198	98	334	299	
	140	85	163							M100x3	120													
	112	112	163																					

HT Series

ISO 6020/2 Hydraulic Cylinders

Fixing accessories

Tie-rods extended head and cap ISO MX1

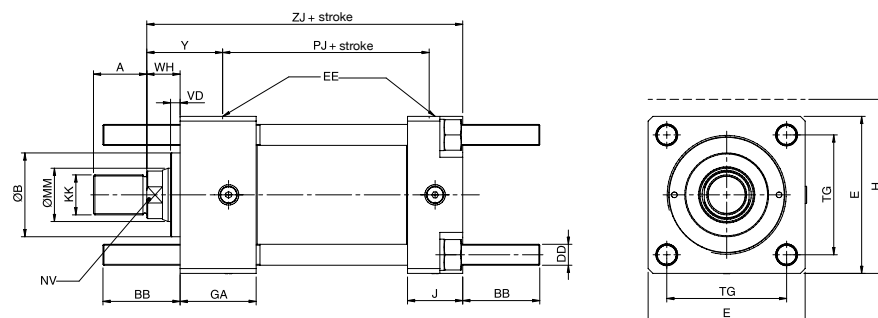
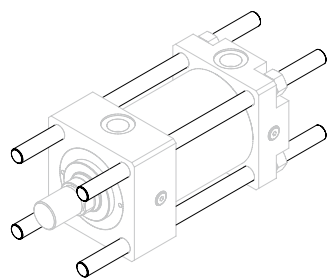

Ø	ØMM	A	B	BB	DD	E	EE	GA	H	J	KK	NV	PJ	TG	VD	WH	Y	ZJ
25	12	14	24	19	M5x0,8	40	1/4"G	50	45	25	M10x1,25	10	53	28,3	6	15	50	114
	18	14	30								M10x1,25	15						
32	14	16	26	24	M6x1	45	1/4"G	50	50	25	M12x1,5	12	56	33,2	12	25	60	128
	22	16	34								M12x1,5	18						
40	18	18	30	35	M8x1	63	3/8"G	55	38	38	M14x1,5	15	73	41,7	12	25	62	153
	28	18	42								M14x1,5	22						
50	22	22	34	46	M12x1,25	75	1/2"G	61	38	38	M16x1,5	18	74	52,3	9	25	67	159
	36	22	50								M16x1,5	30						
63	28	28	42	46	M12x1,25	90	1/2"G	61	38	38	M20x1,5	22	80	64,3	13	32	71	168
	45	28	60								M20x1,5	36						
80	36	36	50	59	M16x1,5	115	3/4"G	70	45	45	M27x2	30	93	82,7	9	31	77	190
	56	36	72								M27x2	46						
100	45	45	60	59	M16x1,5	130	3/4"G	72	45	45	M33x2	36	101	96,9	10	35	82	203
	70	45	88								M33x2	60						
125	56	56	72	81	M22x1,5	165	1"G	80	58	58	M48x2	46	117	125,9	10	35	86	232
	90	56	108								M42x2	80						
160	70	63	88	92	M27x2	205	1"G	83	58	58	M48x2	60	130	154,9	7	32	86	245
	110	63	133								M48x2	100						
200	90	85	108	115	M30x2	245	1 1/4"G	101	76	76	M64x3	80	165	190,2	7	32	98	299
	140	85	163								M64x3	120						

HT Series

ISO 6020/2 Hydraulic Cylinders

Fixing accessories

Tie-rods extended cap end ISO MX2

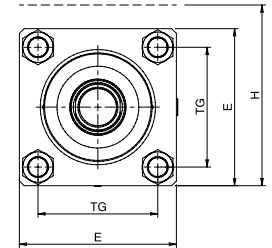
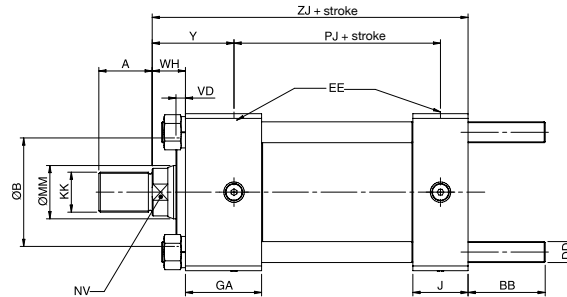
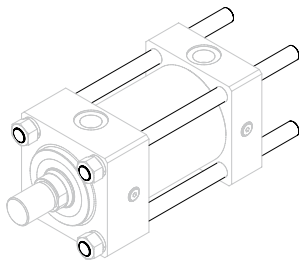

Ø	ØMM	A	B	BB	DD	E	EE	GA	H	J	KK	NV	PJ	TG	VD	WH	Y	ZJ
25	12	14	24	19	M5x0,8	40	1/4"G	50	45	25	M10x1,25	10	53	28,3	6	15	50	114
	18	14	30								M10x1,25							
32	14	16	26	24	M6x1	45	1/4"G	50	50	25	M12x1,5	12	56	33,2	12	25	60	128
	16	16	34								M12x1,5							
	22	18	30								M16x1,5							
40	18	18	30	35	M8x1	63	3/8"G	55	38	38	M14x1,5	15	73	41,7	12	25	62	153
	28	18	42								M14x1,5							
	22	28	34								M20x1,5							
50	22	22	34	46	M12x1,25	75	1/2"G	61	38	38	M16x1,5	18	74	52,3	9	25	67	159
	36	22	50								M16x1,5							
	36	36	50								M27x2							
63	28	28	42	46	M12x1,25	90	1/2"G	61	38	38	M20x1,5	22	80	64,3	13	32	71	168
	45	28	60								M20x1,5							
	45	45	60								M33x2							
80	36	36	50	59	M16x1,5	115	3/4"G	70	45	45	M27x2	30	93	82,7	9	31	77	190
	56	36	72								M27x2							
	56	56	72								M42x2							
100	45	45	60	59	M16x1,5	130	3/4"G	72	45	45	M33x2	36	101	96,9	10	35	82	203
	70	45	88								M33x2							
	63	63	88								M48x2							
125	56	56	72	81	M22x1,5	165	1"G	80	58	58	M42x2	46	117	125,9	10	35	86	232
	90	56	108								M42x2							
	85	85	108								M64x3							
160	70	63	88	92	M27x2	205	1"G	83	58	58	M48x2	60	130	154,9	7	32	86	245
	110	63	133								M48x2							
	95	95	133								M80x3							
200	90	85	108	115	M30x2	245	1 1/4"G	101	76	76	M64x3	80	165	190,2	7	32	98	299
	85	85	163								M64x3							
	140	112	163								M100x3							

HT Series

ISO 6020/2 Hydraulic Cylinders

Fixing accessories

Tie-rods extended head end ISO MX3

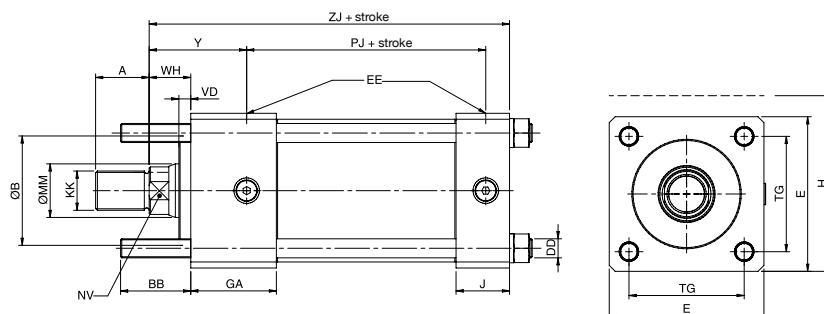
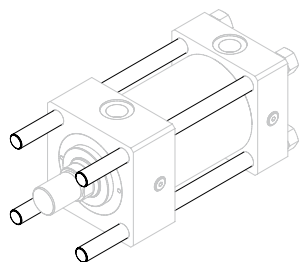

Ø	ØMM	A	B	BB	DD	E	EE	GA	H	J	KK	NV	PJ	TG	VD	WH	Y	ZJ
25	12	14	24	19	M5x0,8	40	1/4"G	50	45	25	M10x1,25	10	53	28,3	6	15	50	114
	18	14	30								M10x1,25							
32	14	16	26	24	M6x1	45	1/4"G	50	50	25	M12x1,5	12	56	33,2	12	25	60	128
	16	34	M12x1,5															
	22	34	M16x1,5															
40	18	18	30	35	M8x1	63	3/8"G	55	38	38	M14x1,5	15	73	41,7	12	25	62	153
	28	42	M14x1,5															
	22	34	M20x1,5															
50	18	18	30	46	M12x1,25	75	1/2"G	61	38	38	M16x1,5	18	74	52,3	9	25	67	159
	22	34	M16x1,5															
	36	50	M27x2															
63	28	28	42	46	M12x1,25	90	1/2"G	61	38	38	M20x1,5	22	80	64,3	13	32	71	168
	45	60	M20x1,5															
	45	60	M33x2															
80	36	36	50	59	M16x1,5	115	3/4"G	70	45	45	M27x2	30	93	82,7	9	31	77	190
	56	72	M27x2															
	45	60	M33x2															
100	70	45	88	59	M16x1,5	130	3/4"G	72	45	45	M33x2	36	101	96,9	10	35	82	203
	63	88	M48x2															
	56	72	M42x2															
125	90	56	108	81	M22x1,5	165	1"G	80	58	58	M42x2	46	117	125,9	10	35	86	232
	85	108	M64x3															
	63	88	M48x2															
160	70	63	88	92	M27x2	205	1"G	83	58	58	M48x2	60	130	154,9	7	32	86	245
	110	133	M48x2															
	95	133	M80x3															
200	90	85	108	115	M30x2	245	1 1/4"G	101	76	76	M64x3	80	165	190,2	7	32	98	299
	85	163	M64x3															
	140	112	M100x3															

Accessories

Hydraulic Cylinders

Swivel head ISO 8133

Valid for series
HR, HT and HV

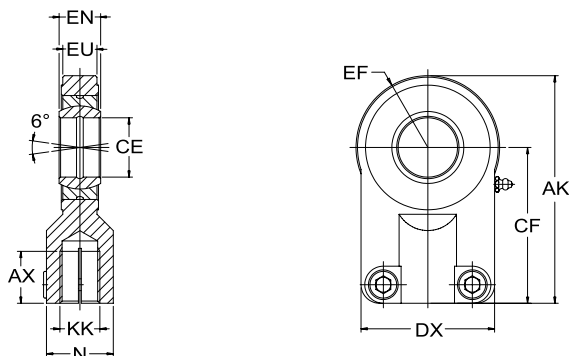

Piston rod	KK (metric)	EN	EU	CE $\varnothing_{-0,008}^0$	EF max.	N max.	DX	CF ^{js13}	AK	AX min.	P/N
14	M12x1,25	14 ⁰ _{-0,12}	11	16 ⁰ _{-0,008}	21	21	45	48	69	17	HRT014AH
18	M14x1,5	16 ⁰ _{-0,12}	13	20 ⁰ _{-0,010}	25	25	55	58	83	19	HRT018AH
22	M16x1,5	20 ⁰ _{-0,12}	17	25 ⁰ _{-0,010}	31	30	62	68	99	23	HRT022AH
28	M20x1,5	22 ⁰ _{-0,12}	19	30 ⁰ _{-0,010}	38	36	80	85	123	29	HRT028AH
36	M27x2	28 ⁰ _{-0,12}	23	40 ⁰ _{-0,012}	48	45	90	105	153	37	HRT036AH
45	M33x2	35 ⁰ _{-0,15}	30	50 ⁰ _{-0,012}	58	55	105	130	188	46	HRT045AH
56	M42x2	44 ⁰ _{-0,15}	38	60 ⁰ _{-0,015}	75	68	134	150	225	57	HRT056AH
70	M48x2	55 ⁰ _{-0,15}	47	80 ⁰ _{-0,015}	97,5	78	156	185	282,2	64	HRT070AH
90	M64x3	70 ⁰ _{-0,20}	57	100 ⁰ _{-0,020}	117,5	100	190	240	357,5	86	HRT090AH

Rod flange ISO 8132

Valid for series
HR, HT and HV

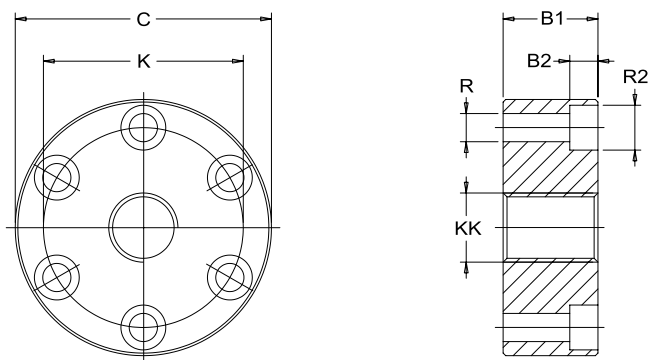

Piston rod	KK (metric)	B1	B2	C \varnothing	K \varnothing	R x N° \varnothing Q.ty	R2	P/N
14	M12x1,25	17	6,8	56	40	6,6 4	11	HRT014AA
18	M14x1,5	19	9	63	45	9 4	14,5	HRT018AA
22	M16x1,5	23	9	72	54	9 6	14,5	HRT022AA
28	M20x1,5	29	9	82	63	9 6	14,5	HRT028AA
36	M27x2	37	11	100	78	11 6	17,5	HRT036AA
45	M33x2	46	13	120	95	13,5 8	20	HRT045AA
56	M42x2	57	17,5	150	120	17,5 8	26	HRT056AA
70	M48x2	64	21,5	190	150	22 8	33	HRT070AA
90	M64x3	86	25	230	180	26 8	40	HRT090AA

Accessories

Hydraulic Cylinders

Fork joint hinge with pin ISO 8133

Valid for series
HR, HT and HV

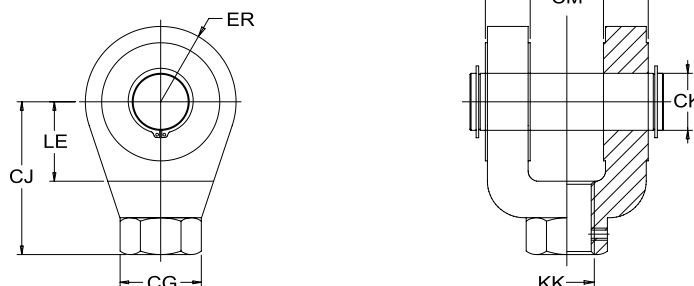

Piston rod	KK (metric)	CK ^{H8} Ø	CL _{máx.}	CM ^{h12}	CJ ^{js13}	LE _{min.}	ER _{máx.}	CG	P/N
14	M12x1,25	12	32	16	36	19	17	21	HRT014AG
18	M14x1,5	14	40	20	38	19	17	21	HRT018AG
22	M16x1,5	20	60	30	54	32	29	32	HRT022AG
28	M20x1,5	20	60	30	60	32	29	32	HRT028AG
36	M27x2	28	80	40	75	39	34	40	HRT036AG
45	M33x2	36	100	50	99	54	50	56	HRT045AG
56	M42x2	45	120	60	113	57	53	56	HRT056AG
70	M48x2	56	140	70	126	63	59	75	HRT070AG
90	M64x3	70	160	80	168	83	78	95	HRT090AG
110	M80x3	70	160	80	168	83	78	95	HRT110AG
140	M100x3	100	230	100	250	90	95	160	HRT140AG

Clevis bracket ISO 8132

Valid for series
HR, HT and HV

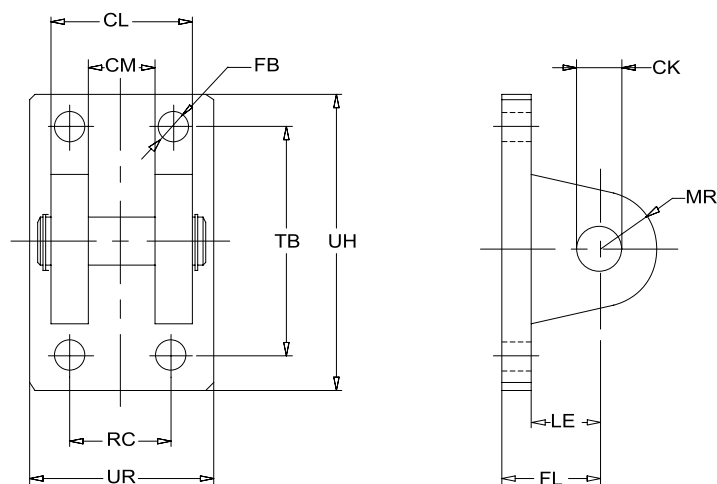

CK ^{H8} Ø	CM ^{A16}	CL ^{h13}	FL ^{js14}	LE	FB Ø	TB ^{js14}	UH	RC ^{js14}	UR	MR	P/N
12	12	28	34	22	9	50	70	20	40	12	HRT012AC
16	16	36	40	27	11	65	90	26	50	16	HRT016AC
20	20	45	45	30	11	75	98	32	58	20	HRT020AC
25	25	56	55	37	13,5	85	113	40	70	25	HRT025AC
32	32	70	65	43	17,5	110	143	50	85	32	HRT032AC
40	40	90	76	52	22	130	170	65	108	40	HRT040AC
50	50	110	95	65	26	170	220	80	130	50	HRT050AC
63	63	140	112	75	33	210	270	100	160	63	HRT063AC
80	80	170	140	95	39	250	320	125	210	80	HRT080AC

Accessories

Hydraulic Cylinders

Trunnion bracket ISO 8132

Valid for series
HR and HT

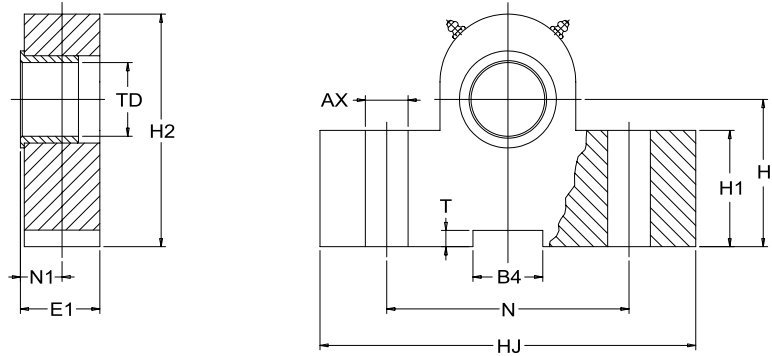

Piston	AX ^{H13} Ø	H ^{A16}	H1	H2 _{máx.}	TD ^{H7}	HJ	E1	N	N1	B4 ^{N9}	T ^{+0,3} +0	P/N
25	9	34	25	49	12	63	17	40	8	10	3,3	HRT025AF
32	11	40	30	59	16	80	21	50	10	16	4,3	HRT032AF
40	11	45	38	69	20	90	21	60	10	16	4,3	HRT040AF
50	13,5	55	45	80	25	110	26	80	12	25	5,4	HRT050AF
63	17,5	65	52	100	32	150	33	110	15	25	5,4	HRT063AF
80	22	76	60	120	40	170	41	125	16	36	8,4	HRT080AF
100	26	95	75	140	50	210	51	160	20	36	8,4	HRT100AF
125	33	112	85	177	63	265	61	200	25	50	11,4	HRT125AF
160	39	140	112	220	80	325	81	250	31	50	11,4	HRT160AF