

HR Series

Round Cylinders / ISO 6020/1 - 160 bar



Technical characteristics

| | | | | | | | | | | | | | | | | | | | | | | | | |
|--|--|----|----|----|----|----|-----|-----|-----|-----|-----|-----|----|----|----|----|----|-----|-----|-----|-----|-----|-----|-----|
| Standard | ISO 6020/1 | | | | | | | | | | | | | | | | | | | | | | | |
| Construction type | With flange and screws | | | | | | | | | | | | | | | | | | | | | | | |
| Rated pressure | 160 bar | | | | | | | | | | | | | | | | | | | | | | | |
| Test pressure | 240 bar | | | | | | | | | | | | | | | | | | | | | | | |
| Ambient temperature | -20°C → +80°C | | | | | | | | | | | | | | | | | | | | | | | |
| | -20°C → +160°C with Viton seals | | | | | | | | | | | | | | | | | | | | | | | |
| Fluid temperature | -20°C → +80°C | | | | | | | | | | | | | | | | | | | | | | | |
| | -20°C → +160°C with Viton seals | | | | | | | | | | | | | | | | | | | | | | | |
| Fluid type | Mineral oil fluid - Other fluids on demand | | | | | | | | | | | | | | | | | | | | | | | |
| Piston (mm) | 25 | 32 | 40 | 50 | 63 | 80 | 100 | 125 | 160 | 200 | 250 | 320 | | | | | | | | | | | | |
| Piston Rod (mm) | 14 | 18 | 18 | 22 | 22 | 28 | 28 | 36 | 36 | 45 | 45 | 56 | 56 | 70 | 70 | 90 | 90 | 110 | 110 | 140 | 140 | 180 | 180 | 220 |
| Maximum speed (m/s) - standard seals | 0,5 | | | | | | 0,4 | | | | | | | | | | | | | | | | | |
| Maximum speed (m/s) - low-friction seals | 1 | | | | | | | | | | | | | | | | | | | | | | | |

HR Series ISO 6020/1 Hydraulic Cylinders

Basic design

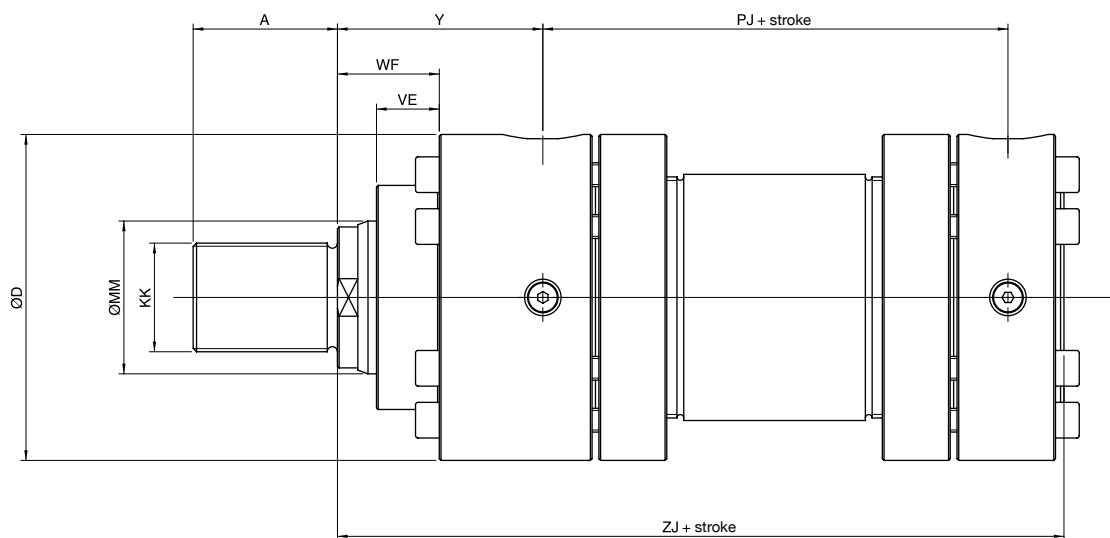

| Ø | ØMM | ZJ | KK 6g | A máx. | Y | PJ | ØD máx. | VE máx. | WF |
|-----|-----|-----|----------|-----------|-----|-----|------------|------------|----|
| 25 | 14 | 150 | M12x1,25 | 16 | 58 | 77 | 56 | 15 | 28 |
| | 18 | | M12x1,25 | 16 | | | | | |
| 32 | 18 | 170 | M14x1,5 | 18 | 64 | 89 | 67 | 19 | 32 |
| | 22 | | M14x1,5 | 18 | | | | | |
| 40 | 22 | 190 | M16x1,5 | 22 | 71 | 97 | 78 | 19 | 32 |
| | 28 | | M16x1,5 | 22 | | | | | |
| 50 | 28 | 205 | M20x1,5 | 28 | 72 | 111 | 95 | 24 | 38 |
| | 36 | | M20x1,5 | 28 | | | | | |
| 63 | 36 | 224 | M27x2 | 36 | 82 | 117 | 116 | 29 | 45 |
| | 45 | | M27x2 | 36 | | | | | |
| 80 | 45 | 250 | M33x2 | 45 | 91 | 134 | 130 | 36 | 54 |
| | 56 | | M33x2 | 45 | | | | | |
| 100 | 56 | 300 | M42x2 | 56 | 108 | 162 | 158 | 37 | 57 |
| | 70 | | M42x2 | 56 | | | | | |
| 125 | 70 | 325 | M48x2 | 63 | 121 | 174 | 192 | 37 | 60 |
| | 90 | | M48x2 | 63 | | | | | |
| 160 | 90 | 370 | M64x3 | 85 | 143 | 191 | 238 | 41 | 66 |
| | 110 | | M64x3 | 85 | | | | | |
| 200 | 110 | 450 | M80x3 | 95 | 190 | 224 | 285 | 45 | 75 |
| | 140 | | M80x3 | 95 | | | | | |
| 250 | 140 | 550 | M100x3 | 112 | 365 | 64 | 96 | 96 | |
| | 180 | | M100x3 | 112 | | | | | |
| 320 | 180 | 660 | M125x4 | 125 | 455 | 71 | 108 | | |
| | 220 | | M125x4 | 125 | | | | | |
| | | | M160x4 | 160 | | | | | |

HR Series

ISO 6020/1 Hydraulic Cylinders

Seal kit

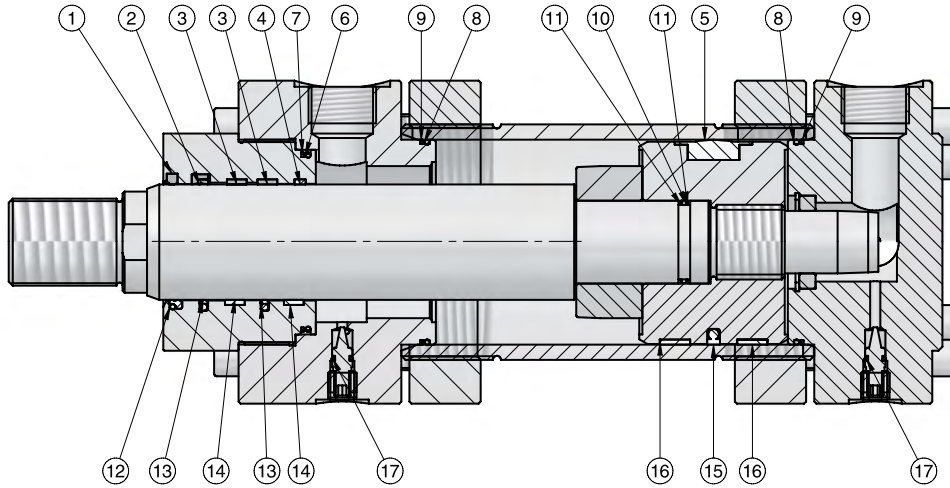

| Position | Description |
|----------|----------------------------|
| 1 | Wiper |
| 2 | Rod seal |
| 3 | Piston-rod guide ring |
| 4 | Piston-rod guide ring |
| 5 | Piston seal |
| 6 | O-ring |
| 7 | Anti-extrusion seal |
| 8 | O-ring |
| 9 | Anti-extrusion seal |
| 10 | O-ring |
| 11 | Anti-extrusion seal |
| 12 | Wiper (low friction) |
| 13 | Rod seal (LF) |
| 14 | Piston-rod guide band (LF) |
| 15 | Piston seal (LF) |
| 16 | Piston-rod guide band (LF) |
| 17 | O-ring |

| ISO 6020/1 Serie | Piston | Rod | Seal type |
|------------------|--------------|--------------|------------------------------------|
| | 025 = 25 mm | 014 = 14 mm | 0 = Standard, medium friction |
| | 032 = 32 mm | 018 = 18 mm | 1 = Low friction |
| | 040 = 40 mm | 022 = 22 mm | 2 = Low friction, high temperature |
| | 050 = 50 mm | 028 = 28 mm | |
| | 063 = 63 mm | 036 = 36 mm | |
| | 080 = 80 mm | 045 = 45 mm | |
| | 100 = 100 mm | 056 = 56 mm | |
| | 125 = 125 mm | 070 = 70 mm | |
| | 160 = 160 mm | 090 = 90 mm | |
| | 200 = 200 mm | 110 = 110 mm | |
| | 250 = 250 mm | 140 = 140 mm | |
| | 320 = 320 mm | 180 = 180 mm | |
| | | 220 = 220 mm | |

HR Series

ISO 6020/1 Hydraulic Cylinders

Fixing accessories

Front rectangular flange mounting ISO MF1

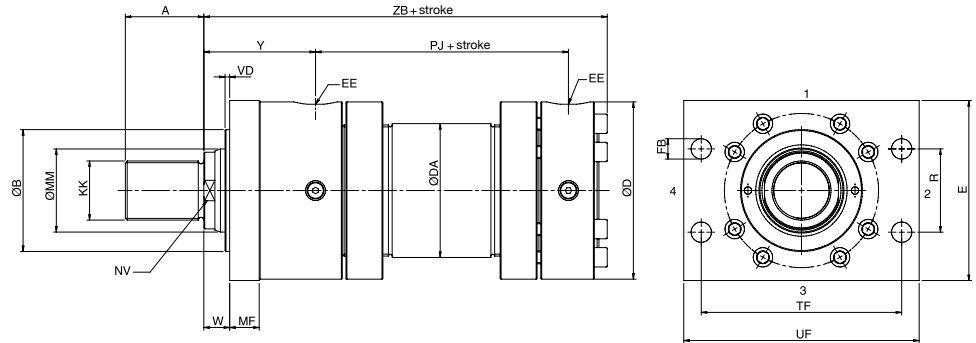
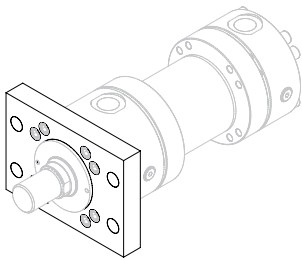

| Ø | ØMM | A | B | ØD | ØDA | E | EE | FB | KK | MF | NV | PJ | R | TF | UF | VD | W | Y | ZB |
|-----|-----|----|-----|-----|-----|-----|-------|------|----------|----|----|-----|------|-------|-----|----|----|-----|-----|
| 25 | 14 | 16 | | | | | | | M12x1,25 | | 12 | | | | | | | | |
| | 18 | 16 | 32 | 56 | 35 | 60 | 1/4"G | 6,6 | M12x1,25 | 12 | 15 | 77 | 28,7 | 69,2 | 85 | 3 | 16 | 58 | 155 |
| 32 | 18 | 18 | | | | | | | M14x1,5 | | 15 | | | | | | | | |
| | 22 | 18 | 40 | 67 | 42 | 70 | 3/8"G | 9 | M14x1,5 | 16 | 17 | 89 | 35,2 | 85 | 105 | 3 | 16 | 64 | 176 |
| 40 | 22 | 22 | | | | | | | M16x1,5 | | 17 | | | | | | | | |
| | 28 | 22 | 50 | 78 | 50 | 80 | 1/2"G | 9 | M16x1,5 | 16 | 22 | 97 | 40,6 | 98 | 115 | 3 | 16 | 71 | 198 |
| 50 | 28 | 28 | | | | | | | M20x1,5 | | 22 | | | | | | | | |
| | 36 | 28 | 60 | 95 | 60 | 100 | 1/2"G | 11 | M20x1,5 | 20 | 28 | 111 | 48,2 | 116,4 | 140 | 4 | 18 | 72 | 213 |
| 63 | 36 | 36 | | | | | | | M27x2 | | 28 | | | | | | | | |
| | 45 | 36 | 70 | 116 | 73 | 120 | 3/4"G | 13,5 | M27x2 | 25 | 36 | 117 | 55,5 | 134 | 160 | 4 | 20 | 82 | 234 |
| 80 | 45 | 45 | | | | | | | M33x2 | | 36 | | | | | | | | |
| | 56 | 45 | 85 | 130 | 95 | 135 | 3/4"G | 17,5 | M33x2 | 32 | 46 | 134 | 63,1 | 152,5 | 185 | 4 | 22 | 91 | 260 |
| 100 | 56 | 56 | | | | | | | M42x2 | | 46 | | | | | | | | |
| | 70 | 56 | 106 | 158 | 115 | 160 | 1"G | 22 | M42x2 | 32 | 60 | 162 | 76,5 | 184,8 | 225 | 5 | 25 | 108 | 310 |
| 125 | 70 | 63 | | | | | | | M48x2 | | 60 | | | | | | | | |
| | 90 | 63 | 132 | 192 | 145 | 195 | 1"G | 22 | M48x2 | 32 | 75 | 174 | 90,2 | 217,1 | 255 | 5 | 28 | 121 | 335 |
| | | 85 | | | | | | | M64x3 | | | | | | | | | | |

HR Series

ISO 6020/1 Hydraulic Cylinders

Fixing accessories

Rear rectangular flange mounting ISO MF2

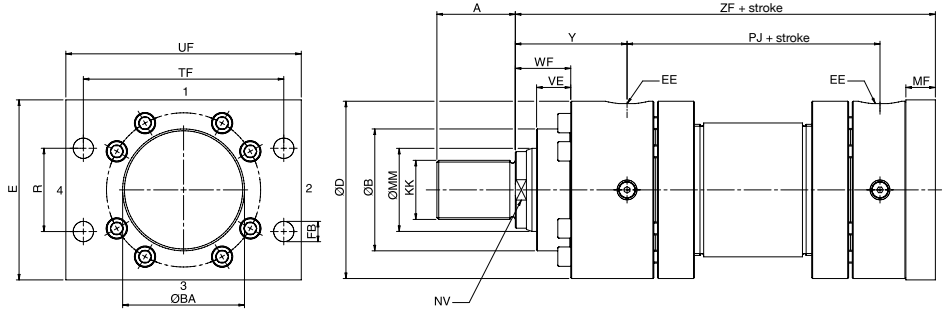
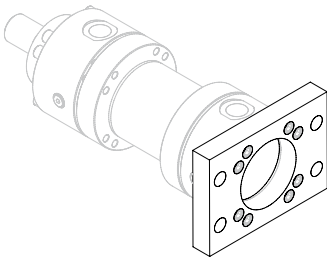

| Ø | ØMM | A | ØB | ØBA | ØD | ØDA | E | EE | FB | KK | MF | NV | PJ | R | TF | UF | VE | WF | Y | ZF | |
|-----|-----|----|-----|-----|-----|-----|-----|-------|------|----------|----|----|-----|------|-------|-----|----|----|-----|-----|--|
| 25 | 14 | 16 | | | | | | | | M12x1,25 | | 12 | | | | | | | | | |
| | 18 | 16 | 32 | 32 | 56 | 35 | 60 | 1/4"G | 6,6 | M12x1,25 | 12 | 15 | 77 | 28,7 | 69,2 | 85 | 15 | 28 | 58 | 162 | |
| 32 | 18 | 18 | | | | | | | | M14x1,5 | | 15 | | | | | | | | | |
| | 22 | 18 | 40 | 40 | 67 | 42 | 70 | 3/8"G | 9 | M14x1,5 | 16 | 17 | 89 | 35,2 | 85 | 105 | 19 | 32 | 64 | 186 | |
| | 22 | 22 | | | | | | | | M16x1,5 | | 17 | | | | | | | | | |
| 40 | 28 | 22 | 50 | 50 | 78 | 50 | 80 | 1/2"G | 9 | M16x1,5 | 16 | 22 | 97 | 40,6 | 98 | 115 | 19 | 32 | 71 | 206 | |
| | 28 | 28 | | | | | | | | M20x1,5 | | 22 | | | | | | | | | |
| | 36 | 28 | 60 | 60 | 95 | 60 | 100 | 1/2"G | 11 | M20x1,5 | 20 | 28 | 111 | 48,2 | 116,4 | 140 | 24 | 38 | 72 | 225 | |
| 63 | 36 | 36 | | | | | | | | M27x2 | | 28 | | | | | | | | | |
| | 45 | 36 | 70 | 70 | 116 | 73 | 120 | 3/4"G | 13,5 | M27x2 | 25 | 36 | 117 | 55,5 | 134 | 160 | 29 | 45 | 82 | 249 | |
| | 45 | 45 | | | | | | | | M33x2 | | 36 | | | | | | | | | |
| 80 | 56 | 45 | 85 | 85 | 130 | 95 | 135 | 3/4"G | 17,5 | M33x2 | 32 | 46 | 134 | 63,1 | 152,5 | 185 | 36 | 54 | 91 | 282 | |
| | 56 | 56 | | | | | | | | M42x2 | | 46 | | | | | | | | | |
| | 70 | 56 | 106 | 106 | 158 | 115 | 160 | 1"G | 22 | M42x2 | 32 | 60 | 162 | 76,5 | 184,8 | 225 | 37 | 57 | 108 | 332 | |
| 125 | 70 | 63 | | | | | | | | M48x2 | | 60 | | | | | | | | | |
| | 90 | 63 | 132 | 132 | 192 | 145 | 195 | 1"G | 22 | M48x2 | 32 | 75 | 174 | 90,2 | 217,1 | 255 | 37 | 60 | 121 | 357 | |
| | | 85 | | | | | | | | M64x3 | | | | | | | | | | | |

HR Series

ISO 6020/1 Hydraulic Cylinders

Fixing accessories

Front round flange mounting ISO MF3

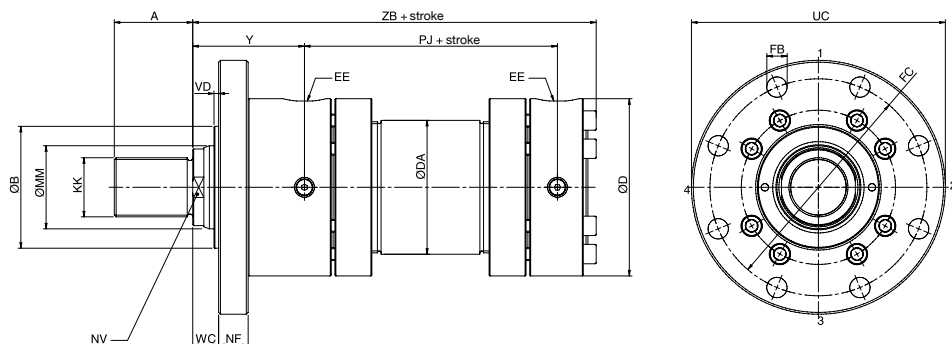
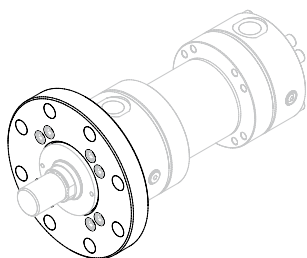

| Ø | ØMM | A | B | ØD | ØDA | EE | FB | FC | KK | NF | NV | PJ | UC | VD | WC | Y | ZB |
|-----|-----|-----|-----|-----|-----|---------|------|-----|----------|----|-----|-----|-----|----|----|-----|-----|
| 25 | 14 | 16 | | | | | | | M12x1,25 | | 12 | | | | | | |
| | 18 | 16 | 32 | 56 | 35 | 1/4"G | 6,6 | 75 | M12x1,25 | 12 | 15 | 77 | 90 | 3 | 16 | 58 | 155 |
| 32 | 18 | 18 | | | | | | | M14x1,5 | | 15 | | | | | | |
| | 22 | 18 | 40 | 67 | 42 | 3/8"G | 9 | 92 | M14x1,5 | 16 | 17 | 89 | 110 | 3 | 16 | 64 | 176 |
| 40 | 22 | 22 | | | | | | | M16x1,5 | | 17 | | | | | | |
| | 28 | 22 | 50 | 78 | 50 | 1/2"G | 9 | 106 | M16x1,5 | 16 | 22 | 97 | 125 | 3 | 16 | 71 | 198 |
| 50 | 28 | 28 | | | | | | | M20x1,5 | | 22 | | | | | | |
| | 36 | 28 | 60 | 95 | 60 | 1/2"G | 11 | 126 | M20x1,5 | 20 | 28 | 111 | 148 | 4 | 18 | 72 | 213 |
| 63 | 36 | 36 | | | | | | | M27x2 | | 28 | | | | | | |
| | 45 | 36 | 70 | 116 | 73 | 3/4"G | 13,5 | 145 | M27x2 | 25 | 36 | 117 | 170 | 4 | 20 | 82 | 234 |
| 80 | 45 | 45 | | | | | | | M33x2 | | 36 | | | | | | |
| | 56 | 45 | 85 | 130 | 95 | 3/4"G | 17,5 | 165 | M33x2 | 32 | 46 | 134 | 195 | 4 | 22 | 91 | 260 |
| 100 | 56 | 56 | | | | | | | M42x2 | | 46 | | | | | | |
| | 70 | 56 | 106 | 158 | 115 | 1"G | 22 | 200 | M42x2 | 32 | 60 | 162 | 238 | 5 | 25 | 108 | 310 |
| 125 | 70 | 63 | | | | | | | M48x2 | | 60 | | | | | | |
| | 90 | 63 | 132 | 192 | 145 | 1"G | 22 | 235 | M48x2 | 32 | 75 | 174 | 272 | 5 | 28 | 121 | 335 |
| 160 | 90 | 85 | | | | | | | M64x3 | | 75 | | | | | | |
| | 110 | 85 | 160 | 232 | 185 | 1 1/4"G | 22 | 280 | M64x3 | 36 | 90 | 191 | 316 | 5 | 30 | 143 | 380 |
| 200 | 110 | 95 | | | | | | | M80x3 | | 90 | | | | | | |
| | 140 | 95 | 200 | 285 | 230 | 1 1/4"G | 26 | 340 | M80x3 | 40 | 120 | 224 | 385 | 5 | 35 | 190 | 474 |
| 250 | 140 | 112 | | | | | | | M100x3 | | 120 | | | | | | |
| | 180 | 112 | 250 | 365 | 298 | 1 1/2"G | 33 | 420 | M100x3 | 56 | 160 | 290 | 500 | 8 | 40 | 205 | 580 |
| 320 | 180 | 125 | | | | | | | M125x4 | | 160 | | | | | | |
| | 220 | 125 | 320 | 450 | 368 | 1 1/2"G | 39 | 520 | M125x4 | 63 | 200 | 358 | 620 | 8 | 45 | 250 | 696 |
| | | 160 | | | | | | | M160x4 | | | | | | | | |

HR Series

ISO 6020/1 Hydraulic Cylinders

Fixing accessories

Rear round flange mounting ISO MF4

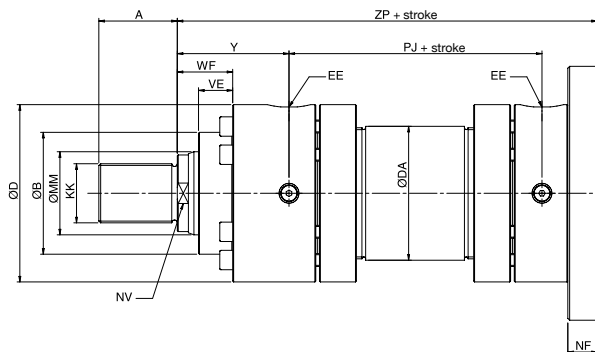
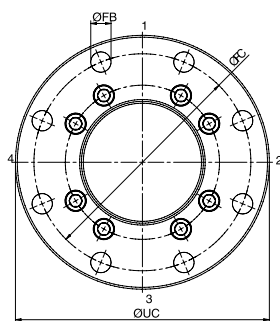
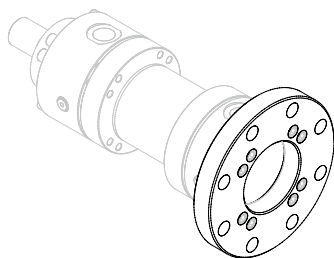

| Ø | ØMM | A | B | ØD | ØDA | EE | FB | FC | KK | NF | NV | PJ | UC | VE | WF | Y | ZP |
|-----|-----|-----|-----|-----|-----|---------|------|-----|----------|----|-----|-----|-----|----|----|-----|-----|
| 25 | 14 | 16 | | | | | | | M12x1,25 | | 12 | | | | | | |
| | 18 | 16 | 32 | 56 | 35 | 1/4"G | 6,6 | 75 | M12x1,25 | 12 | 15 | 77 | 90 | 15 | 16 | 58 | 162 |
| 32 | 18 | 18 | | | | | | | M14x1,5 | | 15 | | | | | | |
| | 22 | 18 | 40 | 67 | 42 | 3/8"G | 9 | 92 | M14x1,5 | 16 | 17 | 89 | 110 | 19 | 16 | 64 | 186 |
| | 22 | 22 | | | | | | | M16x1,5 | | 17 | | | | | | |
| 40 | 28 | 22 | 50 | 78 | 50 | 1/2"G | 9 | 106 | M16x1,5 | 16 | 22 | 97 | 125 | 19 | 16 | 71 | 206 |
| | 28 | 28 | | | | | | | M20x1,5 | | 22 | | | | | | |
| 50 | 36 | 28 | 60 | 95 | 60 | 1/2"G | 11 | 126 | M20x1,5 | 20 | 28 | 111 | 148 | 24 | 18 | 72 | 225 |
| | 36 | 36 | | | | | | | M27x2 | | 28 | | | | | | |
| 63 | 45 | 36 | 70 | 116 | 73 | 3/4"G | 13,5 | 145 | M27x2 | 25 | 36 | 117 | 170 | 29 | 20 | 82 | 249 |
| | 45 | 45 | | | | | | | M33x2 | | 36 | | | | | | |
| 80 | 56 | 45 | 85 | 130 | 95 | 3/4"G | 17,5 | 165 | M33x2 | 32 | 46 | 134 | 195 | 36 | 22 | 91 | 282 |
| | 56 | 56 | | | | | | | M42x2 | | 46 | | | | | | |
| 100 | 70 | 56 | 106 | 158 | 115 | 1"G | 22 | 200 | M42x2 | 32 | 60 | 162 | 238 | 37 | 25 | 108 | 332 |
| | 70 | 63 | | | | | | | M48x2 | | 60 | | | | | | |
| 125 | 90 | 63 | 132 | 192 | 145 | 1"G | 22 | 235 | M48x2 | 32 | 75 | 174 | 272 | 37 | 28 | 121 | 357 |
| | 90 | 85 | | | | | | | M64x3 | | 75 | | | | | | |
| 160 | 110 | 85 | 160 | 232 | 185 | 1 1/4"G | 22 | 280 | M64x3 | 36 | 90 | 191 | 316 | 41 | 30 | 143 | 406 |
| | 110 | 95 | | | | | | | M80x3 | | 90 | | | | | | |
| 200 | 140 | 95 | 200 | 285 | 230 | 1 1/4"G | 26 | 340 | M80x3 | 40 | 120 | 224 | 385 | 45 | 35 | 190 | 490 |
| | 140 | 112 | | | | | | | M100x3 | | 120 | | | | | | |
| 250 | 180 | 112 | 250 | 365 | 298 | 1 1/2"G | 33 | 420 | M100x3 | 56 | 160 | 290 | 500 | 64 | 40 | 205 | 606 |
| | 180 | 125 | | | | | | | M125x4 | | 160 | | | | | | |
| 320 | 220 | 125 | 320 | 450 | 368 | 1 1/2"G | 39 | 520 | M125x4 | 63 | 200 | 358 | 620 | 71 | 45 | 250 | 723 |
| | 220 | 160 | | | | | | | M160x4 | | 200 | | | | | | |

HR Series

ISO 6020/1 Hydraulic Cylinders

Fixing accessories

Eye mounting ISO MP3

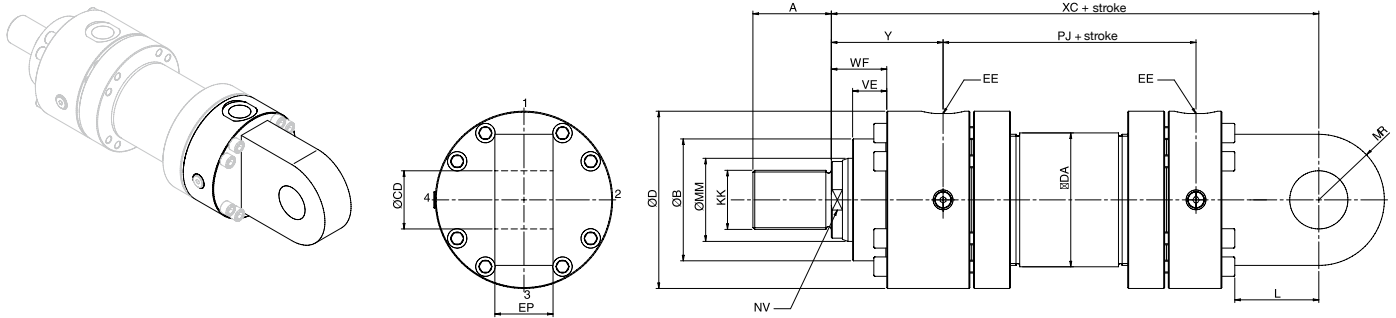

| Ø | ØMM | A | B | ØD | ØDA | EE | CD | EP | KK | L | MR | NV | PJ | VE | WF | Y | XC |
|-----|-----|-----|-----|-----|-----|---------|-----|-----|----------|-----|-----|-----|-----|----|-----|-----|-----|
| 25 | 14 | 16 | | | | | | | M12x1,25 | | | 12 | | | | | |
| | 18 | 16 | 32 | 56 | 35 | 1/4"G | 12 | 12 | M12x1,25 | 20 | 16 | 15 | 77 | 15 | 28 | 58 | 178 |
| 32 | 18 | 18 | | | | | | | M14x1,5 | | | 15 | | | | | |
| | 22 | 18 | 40 | 67 | 42 | 3/8"G | 16 | 16 | M14x1,5 | 28 | 20 | 17 | 89 | 19 | 32 | 64 | 206 |
| 40 | 22 | 22 | | | | | | | M16x1,5 | | | 17 | | | | | |
| | 28 | 22 | 50 | 78 | 50 | 1/2"G | 20 | 20 | M16x1,5 | 35 | 25 | 22 | 97 | 19 | 32 | 71 | 231 |
| 50 | 28 | 28 | | | | | | | M20x1,5 | | | 22 | | | | | |
| | 36 | 28 | 60 | 95 | 60 | 1/2"G | 25 | 25 | M20x1,5 | 44 | 32 | 28 | 111 | 24 | 38 | 72 | 257 |
| 63 | 36 | 36 | | | | | | | M27x2 | | | 28 | | | | | |
| | 45 | 36 | 70 | 116 | 73 | 3/4"G | 32 | 32 | M27x2 | 55 | 40 | 36 | 117 | 29 | 45 | 82 | 289 |
| 80 | 45 | 45 | | | | | | | M33x2 | | | 36 | | | | | |
| | 56 | 45 | 85 | 130 | 95 | 3/4"G | 40 | 40 | M33x2 | 70 | 50 | 46 | 134 | 36 | 54 | 91 | 332 |
| 100 | 56 | 56 | | | | | | | M42x2 | | | 46 | | | | | |
| | 70 | 56 | 106 | 158 | 115 | 1"G | 50 | 50 | M42x2 | 81 | 63 | 60 | 162 | 37 | 57 | 108 | 395 |
| 125 | 70 | 63 | | | | | | | M48x2 | | | 60 | | | | | |
| | 90 | 63 | 132 | 192 | 145 | 1"G | 63 | 63 | M48x2 | 91 | 80 | 75 | 174 | 37 | 60 | 121 | 428 |
| 160 | 90 | 85 | | | | | | | M64x3 | | | 75 | | | | | |
| | 110 | 85 | 160 | 232 | 185 | 1 1/4"G | 80 | 80 | M64x3 | 121 | 100 | 90 | 191 | 41 | 66 | 143 | 505 |
| 200 | 110 | 95 | | | | | | | M80x3 | | | 90 | | | | | |
| | 140 | 95 | 200 | 285 | 230 | 1 1/4"G | 100 | 100 | M80x3 | 149 | 125 | 120 | 224 | 45 | 75 | 190 | 615 |
| 250 | 140 | 112 | | | | | | | M100x3 | | | 120 | | | | | |
| | 180 | 112 | 250 | 365 | 298 | 1 1/2"G | 125 | 125 | M100x3 | 203 | 160 | 160 | 290 | 64 | 96 | 205 | 773 |
| 320 | 180 | 125 | | | | | | | M125x4 | | | 160 | | | | | |
| | 220 | 125 | 320 | 450 | 368 | 1 1/2"G | 160 | 160 | M125x4 | 242 | 200 | 200 | 358 | 71 | 108 | 250 | 930 |

HR Series

ISO 6020/1 Hydraulic Cylinders

Fixing accessories

Spherical eye mounting ISO MP5

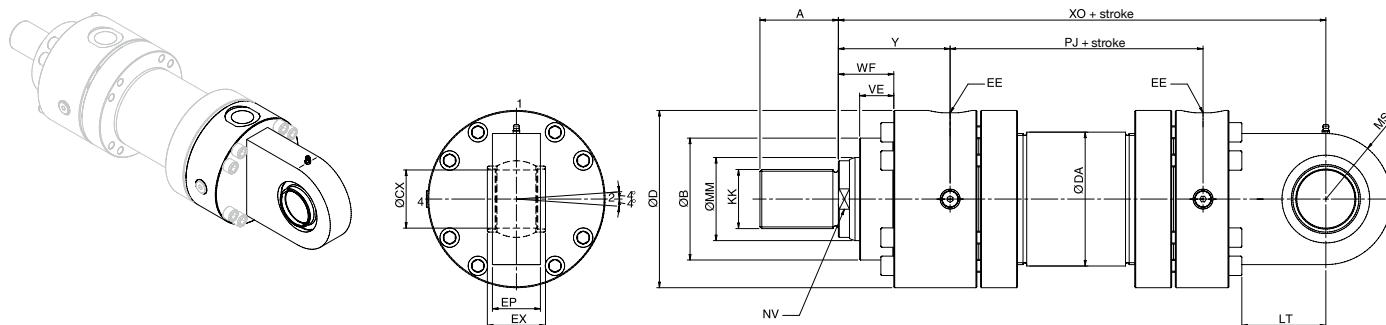

| Ø | ØMM | A | CX | B | ØD | ØDA | EE | EX | EP | KK | LT | MS | NV | PJ | VE | WF | Y | XO |
|-----|-----|-----|-----|-----|-----|-----|---------|-----|------|----------|-----|-----|-----|-----|----|-----|-----|-----|
| 25 | 14 | 16 | | | | | | | | M12x1,25 | | | 12 | | | | | |
| | 18 | 16 | 12 | 32 | 56 | 35 | 1/4"G | 12 | 10,6 | M12x1,25 | 20 | 16 | 15 | 77 | 15 | 28 | 58 | 178 |
| 32 | 18 | 18 | | | | | | | | M14x1,5 | | | 15 | | | | | |
| | 22 | 18 | 16 | 40 | 67 | 42 | 3/8"G | 16 | 14 | M14x1,5 | 28 | 20 | 17 | 89 | 19 | 32 | 64 | 206 |
| 40 | 22 | 22 | | | | | | | | M16x1,5 | | | 17 | | | | | |
| | 28 | 22 | 20 | 50 | 78 | 50 | 1/2"G | 20 | 18 | M16x1,5 | 35 | 25 | 22 | 97 | 19 | 32 | 71 | 231 |
| 50 | 28 | 28 | | | | | | | | M20x1,5 | | | 22 | | | | | |
| | 36 | 28 | 25 | 60 | 95 | 60 | 1/2"G | 25 | 22 | M20x1,5 | 44 | 32 | 28 | 111 | 24 | 38 | 72 | 257 |
| 63 | 36 | 36 | | | | | | | | M27x2 | | | 28 | | | | | |
| | 45 | 36 | 32 | 70 | 116 | 73 | 3/4"G | 32 | 27 | M27x2 | 55 | 40 | 36 | 117 | 29 | 45 | 82 | 289 |
| 80 | 45 | 45 | | | | | | | | M33x2 | | | 36 | | | | | |
| | 56 | 45 | 40 | 85 | 130 | 95 | 3/4"G | 40 | 35 | M33x2 | 70 | 50 | 46 | 134 | 36 | 54 | 91 | 332 |
| 100 | 56 | 56 | | | | | | | | M42x2 | | | 46 | | | | | |
| | 70 | 56 | 50 | 106 | 158 | 115 | 1"G | 50 | 40 | M42x2 | 81 | 63 | 60 | 162 | 37 | 57 | 108 | 395 |
| 125 | 70 | 63 | | | | | | | | M48x2 | | | 60 | | | | | |
| | 90 | 63 | 63 | 132 | 192 | 145 | 1"G | 63 | 52 | M48x2 | 91 | 80 | 75 | 174 | 37 | 60 | 121 | 428 |
| 160 | 90 | 85 | | | | | | | | M64x3 | | | 75 | | | | | |
| | 110 | 85 | 80 | 160 | 232 | 185 | 1 1/4"G | 80 | 66 | M64x3 | 121 | 100 | 90 | 191 | 41 | 66 | 143 | 505 |
| 200 | 110 | 95 | | | | | | | | M80x3 | | | 90 | | | | | |
| | 140 | 95 | 100 | 200 | 285 | 230 | 1 1/4"G | 100 | 84 | M80x3 | 149 | 125 | 120 | 224 | 45 | 75 | 190 | 615 |
| 250 | 140 | 112 | | | | | | | | M100x3 | | | 120 | | | | | |
| | 180 | 112 | 125 | 250 | 365 | 298 | 1 1/2"G | 125 | 102 | M100x3 | 203 | 160 | 160 | 290 | 64 | 96 | 205 | 773 |
| 320 | 180 | 125 | | | | | | | | M125x4 | | | 160 | | | | | |
| | 220 | 125 | 160 | 320 | 450 | 368 | 1 1/2"G | 160 | 130 | M125x4 | 242 | 200 | 200 | 358 | 71 | 108 | 250 | 930 |

HR Series ISO 6020/1 Hydraulic Cylinders Fixing accessories

Foot mounting ISO MS2

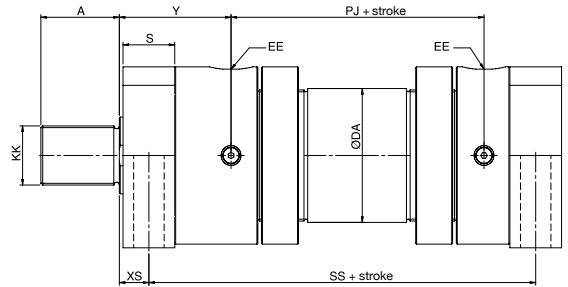
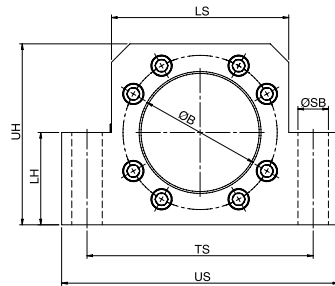
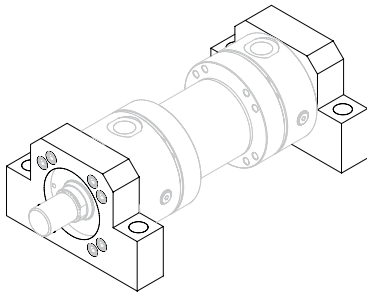

| Ø | ØMM | A | ØB | ØDA | EE | KK | LH | LS | PJ | S | ØSB | SS | TS | UH | US | XS | Y |
|-----|-----|-----|-----|-----|---------|----------|-----|-----|-----|----|-----|-----|-----|-----|-----|-----|-----|
| 25 | 14 | 16 | | | | M12x1,25 | | | | | | | | | | | |
| | 18 | 16 | 32 | 35 | 1/4"G | M12x1,25 | 32 | 56 | 77 | 20 | 9 | 142 | 63 | 83 | 92 | 58 | 58 |
| 32 | 18 | 18 | | | | M14x1,5 | | | | | | | | | | | |
| | 22 | 18 | 40 | 42 | 3/8"G | M14x1,5 | 38 | 67 | 89 | 25 | 11 | 163 | 75 | 99 | 110 | 64 | 64 |
| 40 | 22 | 22 | | | | M16x1,5 | | | | | | | | | | | |
| | 28 | 22 | 50 | 50 | 1/2"G | M16x1,5 | 43 | 78 | 97 | 25 | 11 | 183 | 90 | 122 | 120 | 71 | 71 |
| 50 | 28 | 28 | | | | M20x1,5 | | | | | | | | | | | |
| | 36 | 28 | 60 | 60 | 1/2"G | M20x1,5 | 52 | 95 | 111 | 32 | 14 | 199 | 105 | 145 | 145 | 72 | 72 |
| 63 | 36 | 36 | | | | M27x2 | | | | | | | | | | | |
| | 45 | 36 | 70 | 73 | 3/4"G | M27x2 | 62 | 116 | 117 | 32 | 18 | 211 | 120 | 170 | 180 | 82 | 82 |
| 80 | 45 | 45 | | | | M33x2 | | | | | | | | | | | |
| | 56 | 45 | 85 | 95 | 3/4"G | M33x2 | 70 | 130 | 134 | 40 | 22 | 236 | 135 | 199 | 210 | 91 | 91 |
| 100 | 56 | 56 | | | | M42x2 | | | | | | | | | | | |
| | 70 | 56 | 106 | 115 | 1"G | M42x2 | 82 | 158 | 162 | 50 | 26 | 293 | 160 | 240 | 250 | 108 | 108 |
| 125 | 70 | 63 | | | | M48x2 | | | | | | | | | | | |
| | 90 | 63 | 132 | 145 | 1"G | M48x2 | 100 | 192 | 174 | 56 | 33 | 321 | 195 | 295 | 300 | 121 | 121 |
| 160 | 90 | 85 | | | | M64x3 | | | | | | | | | | | |
| | 110 | 85 | 160 | 185 | 1 1/4"G | M64x3 | 119 | 238 | 191 | 60 | 33 | 364 | 240 | 321 | 350 | 143 | 143 |
| 200 | 110 | 95 | | | | M80x3 | | | | | | | | | | | |
| | 140 | 95 | 200 | 230 | 1 1/4"G | M80x3 | 145 | 285 | 224 | 72 | 39 | 447 | 295 | 455 | 415 | 190 | 190 |
| | | 112 | | | | M100x3 | | | | | | | | | | | |

HR Series

ISO 6020/1 Hydraulic Cylinders

Fixing accessories

Intermediate trunnion ISO MT4

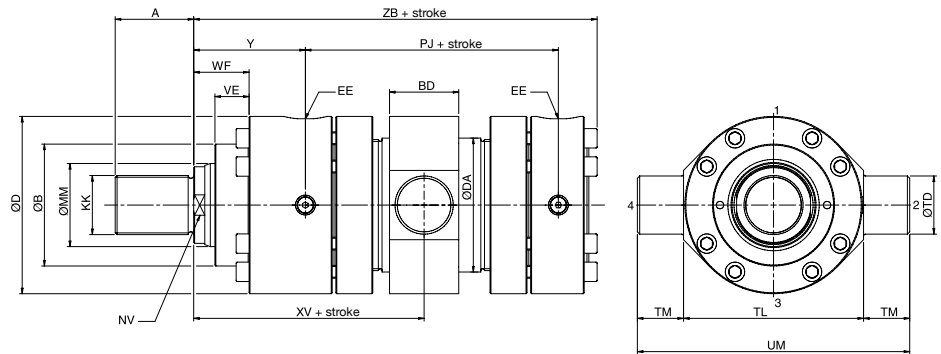
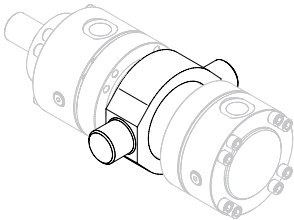

| Ø | ØMM | A | B | ØD | ØDA | BD | EE | KK | NV | PJ | ØTD | TL | TM | UM | VE | WF | Y | XV _(min) | ZB |
|-----|-----|-----|-----|-----|-----|-----|---------|----------|-----|-----|-----|-----|-----|-----|----|-----|-----|---------------------|-----|
| 25 | 14 | 16 | | | | | | M12x1,25 | 12 | | | | | | | | | | |
| | 18 | 16 | 32 | 56 | 35 | 20 | 1/4"G | M12x1,25 | 15 | 77 | 12 | 63 | 10 | 83 | 15 | 28 | 58 | 107 | 135 |
| 32 | 18 | 18 | | | | | | M14x1,5 | 15 | | | | | | | | | | |
| | 22 | 18 | 40 | 67 | 42 | 25 | 3/8"G | M14x1,5 | 17 | 89 | 16 | 75 | 12 | 99 | 19 | 32 | 64 | 120 | 153 |
| 40 | 22 | 22 | | | | | | M16x1,5 | 17 | | | | | | | | | | |
| | 28 | 22 | 50 | 78 | 50 | 30 | 1/2"G | M16x1,5 | 22 | 97 | 20 | 90 | 16 | 122 | 19 | 32 | 71 | 135 | 148 |
| 50 | 28 | 28 | | | | | | M20x1,5 | 22 | | | | | | | | | | |
| | 36 | 28 | 60 | 95 | 60 | 35 | 1/2"G | M20x1,5 | 28 | 111 | 25 | 105 | 20 | 145 | 24 | 38 | 72 | 145 | 183 |
| 63 | 36 | 36 | | | | | | M27x2 | 28 | | | | | | | | | | |
| | 45 | 36 | 70 | 116 | 73 | 45 | 3/4"G | M27x2 | 36 | 117 | 32 | 120 | 25 | 170 | 29 | 45 | 82 | 165 | 199 |
| 80 | 45 | 45 | | | | | | M33x2 | 36 | | | | | | | | | | |
| | 56 | 45 | 85 | 130 | 95 | 50 | 3/4"G | M33x2 | 46 | 134 | 40 | 135 | 32 | 199 | 36 | 54 | 91 | 178 | 225 |
| 100 | 56 | 56 | | | | | | M42x2 | 46 | | | | | | | | | | |
| | 70 | 56 | 106 | 158 | 115 | 60 | 1"G | M42x2 | 60 | 162 | 50 | 160 | 40 | 240 | 37 | 57 | 108 | 215 | 270 |
| 125 | 70 | 63 | | | | | | M48x2 | 60 | | | | | | | | | | |
| | 90 | 63 | 132 | 192 | 145 | 75 | 1"G | M48x2 | 75 | 174 | 63 | 195 | 50 | 295 | 37 | 60 | 121 | 240 | 295 |
| 160 | 90 | 85 | | | | | | M64x3 | 75 | | | | | | | | | | |
| | 110 | 85 | 160 | 232 | 185 | 90 | 1 1/4"G | M64x3 | 90 | 191 | 80 | 240 | 63 | 321 | 41 | 66 | 143 | 280 | 334 |
| 200 | 110 | 95 | | | | | | M80x3 | 90 | | | | | | | | | | |
| | 140 | 95 | 200 | 285 | 230 | 110 | 1 1/4"G | M80x3 | 120 | 224 | 100 | 295 | 80 | 455 | 45 | 75 | 190 | 350 | 414 |
| 250 | 140 | 112 | | | | | | M100x3 | 120 | | | | | | | | | | |
| | 180 | 112 | 250 | 365 | 298 | 135 | 1 1/2"G | M100x3 | 160 | 290 | 125 | 370 | 100 | 570 | 64 | 96 | 205 | 395 | 495 |
| 320 | 180 | 125 | | | | | | M125x4 | 160 | | | | | | | | | | |
| | 220 | 125 | 320 | 450 | 368 | 175 | 1 1/2"G | M125x4 | 200 | 358 | 160 | 470 | 125 | 720 | 71 | 108 | 250 | 495 | 608 |

Accessories

Hydraulic Cylinders

Swivel head ISO 8133

Valid for series
HR, HT and HV

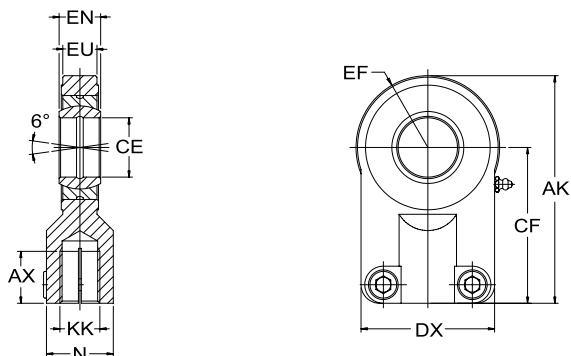

| Piston rod | KK (metric) | EN | EU | CE $\varnothing_{-0,008}^0$ | EF max. | N max. | DX | CF ^{js13} | AK | AX min. | P/N |
|------------|-------------|----------------------------------|----|------------------------------------|------------|-----------|-----|--------------------|-------|------------|----------|
| 14 | M12x1,25 | 14 ⁰ _{-0,12} | 11 | 16 ⁰ _{-0,008} | 21 | 21 | 45 | 48 | 69 | 17 | HRT014AH |
| 18 | M14x1,5 | 16 ⁰ _{-0,12} | 13 | 20 ⁰ _{-0,010} | 25 | 25 | 55 | 58 | 83 | 19 | HRT018AH |
| 22 | M16x1,5 | 20 ⁰ _{-0,12} | 17 | 25 ⁰ _{-0,010} | 31 | 30 | 62 | 68 | 99 | 23 | HRT022AH |
| 28 | M20x1,5 | 22 ⁰ _{-0,12} | 19 | 30 ⁰ _{-0,010} | 38 | 36 | 80 | 85 | 123 | 29 | HRT028AH |
| 36 | M27x2 | 28 ⁰ _{-0,12} | 23 | 40 ⁰ _{-0,012} | 48 | 45 | 90 | 105 | 153 | 37 | HRT036AH |
| 45 | M33x2 | 35 ⁰ _{-0,15} | 30 | 50 ⁰ _{-0,012} | 58 | 55 | 105 | 130 | 188 | 46 | HRT045AH |
| 56 | M42x2 | 44 ⁰ _{-0,15} | 38 | 60 ⁰ _{-0,015} | 75 | 68 | 134 | 150 | 225 | 57 | HRT056AH |
| 70 | M48x2 | 55 ⁰ _{-0,15} | 47 | 80 ⁰ _{-0,015} | 97,5 | 78 | 156 | 185 | 282,2 | 64 | HRT070AH |
| 90 | M64x3 | 70 ⁰ _{-0,20} | 57 | 100 ⁰ _{-0,020} | 117,5 | 100 | 190 | 240 | 357,5 | 86 | HRT090AH |

Rod flange ISO 8132

Valid for series
HR, HT and HV

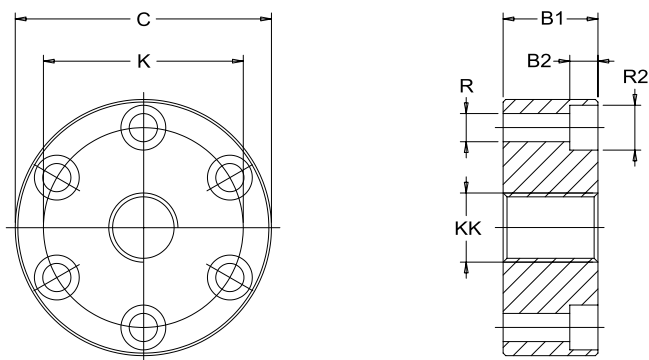

| Piston rod | KK (metric) | B1 | B2 | C \varnothing | K \varnothing | R x N° \varnothing Q.ty | R2 | P/N |
|------------|-------------|----|------|--------------------|--------------------|------------------------------|------|----------|
| 14 | M12x1,25 | 17 | 6,8 | 56 | 40 | 6,6 4 | 11 | HRT014AA |
| 18 | M14x1,5 | 19 | 9 | 63 | 45 | 9 4 | 14,5 | HRT018AA |
| 22 | M16x1,5 | 23 | 9 | 72 | 54 | 9 6 | 14,5 | HRT022AA |
| 28 | M20x1,5 | 29 | 9 | 82 | 63 | 9 6 | 14,5 | HRT028AA |
| 36 | M27x2 | 37 | 11 | 100 | 78 | 11 6 | 17,5 | HRT036AA |
| 45 | M33x2 | 46 | 13 | 120 | 95 | 13,5 8 | 20 | HRT045AA |
| 56 | M42x2 | 57 | 17,5 | 150 | 120 | 17,5 8 | 26 | HRT056AA |
| 70 | M48x2 | 64 | 21,5 | 190 | 150 | 22 8 | 33 | HRT070AA |
| 90 | M64x3 | 86 | 25 | 230 | 180 | 26 8 | 40 | HRT090AA |

Accessories

Hydraulic Cylinders

Fork joint hinge with pin ISO 8133

Valid for series
HR, HT and HV

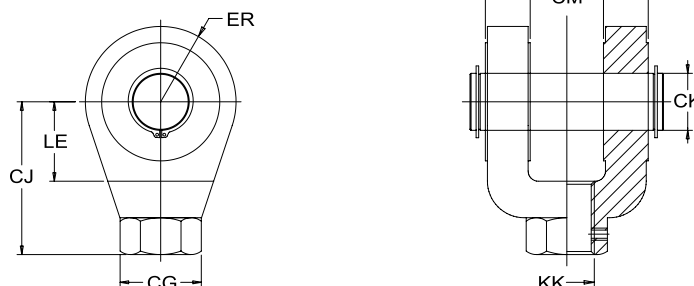

| Piston rod | KK (metric) | CK ^{H8} Ø | CL _{máx.} | CM ^{h12} | CJ ^{js13} | LE _{min.} | ER _{máx.} | CG | P/N |
|------------|-------------|--------------------|--------------------|-------------------|--------------------|--------------------|--------------------|-----|----------|
| 14 | M12x1,25 | 12 | 32 | 16 | 36 | 19 | 17 | 21 | HRT014AG |
| 18 | M14x1,5 | 14 | 40 | 20 | 38 | 19 | 17 | 21 | HRT018AG |
| 22 | M16x1,5 | 20 | 60 | 30 | 54 | 32 | 29 | 32 | HRT022AG |
| 28 | M20x1,5 | 20 | 60 | 30 | 60 | 32 | 29 | 32 | HRT028AG |
| 36 | M27x2 | 28 | 80 | 40 | 75 | 39 | 34 | 40 | HRT036AG |
| 45 | M33x2 | 36 | 100 | 50 | 99 | 54 | 50 | 56 | HRT045AG |
| 56 | M42x2 | 45 | 120 | 60 | 113 | 57 | 53 | 56 | HRT056AG |
| 70 | M48x2 | 56 | 140 | 70 | 126 | 63 | 59 | 75 | HRT070AG |
| 90 | M64x3 | 70 | 160 | 80 | 168 | 83 | 78 | 95 | HRT090AG |
| 110 | M80x3 | 70 | 160 | 80 | 168 | 83 | 78 | 95 | HRT110AG |
| 140 | M100x3 | 100 | 230 | 100 | 250 | 90 | 95 | 160 | HRT140AG |

Clevis bracket ISO 8132

Valid for series
HR, HT and HV

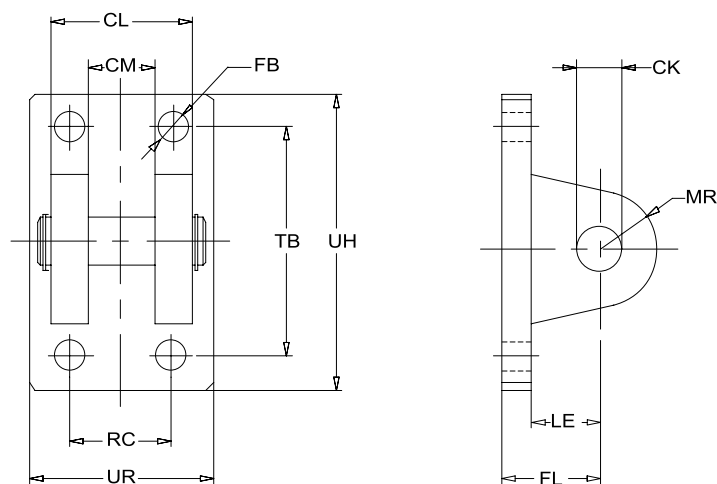

| CK ^{H8} Ø | CM ^{A16} | CL ^{h13} | FL ^{js14} | LE | FB Ø | TB ^{js14} | UH | RC ^{js14} | UR | MR | P/N |
|--------------------|-------------------|-------------------|--------------------|----|------|--------------------|-----|--------------------|-----|----|----------|
| 12 | 12 | 28 | 34 | 22 | 9 | 50 | 70 | 20 | 40 | 12 | HRT012AC |
| 16 | 16 | 36 | 40 | 27 | 11 | 65 | 90 | 26 | 50 | 16 | HRT016AC |
| 20 | 20 | 45 | 45 | 30 | 11 | 75 | 98 | 32 | 58 | 20 | HRT020AC |
| 25 | 25 | 56 | 55 | 37 | 13,5 | 85 | 113 | 40 | 70 | 25 | HRT025AC |
| 32 | 32 | 70 | 65 | 43 | 17,5 | 110 | 143 | 50 | 85 | 32 | HRT032AC |
| 40 | 40 | 90 | 76 | 52 | 22 | 130 | 170 | 65 | 108 | 40 | HRT040AC |
| 50 | 50 | 110 | 95 | 65 | 26 | 170 | 220 | 80 | 130 | 50 | HRT050AC |
| 63 | 63 | 140 | 112 | 75 | 33 | 210 | 270 | 100 | 160 | 63 | HRT063AC |
| 80 | 80 | 170 | 140 | 95 | 39 | 250 | 320 | 125 | 210 | 80 | HRT080AC |

Accessories

Hydraulic Cylinders

Trunnion bracket ISO 8132

Valid for series
HR and HT

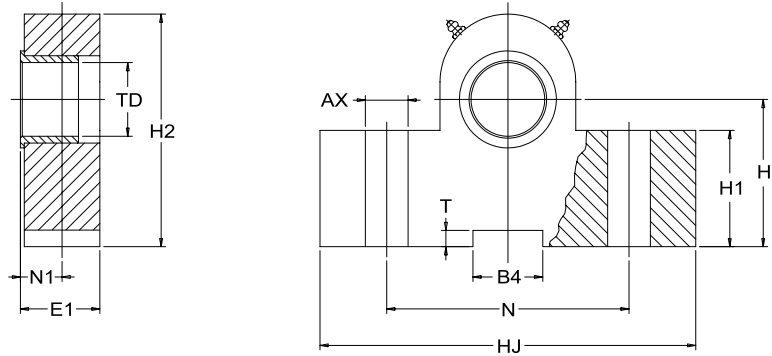

| Piston | AX ^{H13} Ø | H ^{A16} | H1 | H2 _{máx.} | TD ^{H7} | HJ | E1 | N | N1 | B4 ^{N9} | T ^{+0,3} +0 | P/N |
|--------|------------------------|------------------|-----|--------------------|------------------|-----|----|-----|----|------------------|-------------------------|----------|
| 25 | 9 | 34 | 25 | 49 | 12 | 63 | 17 | 40 | 8 | 10 | 3,3 | HRT025AF |
| 32 | 11 | 40 | 30 | 59 | 16 | 80 | 21 | 50 | 10 | 16 | 4,3 | HRT032AF |
| 40 | 11 | 45 | 38 | 69 | 20 | 90 | 21 | 60 | 10 | 16 | 4,3 | HRT040AF |
| 50 | 13,5 | 55 | 45 | 80 | 25 | 110 | 26 | 80 | 12 | 25 | 5,4 | HRT050AF |
| 63 | 17,5 | 65 | 52 | 100 | 32 | 150 | 33 | 110 | 15 | 25 | 5,4 | HRT063AF |
| 80 | 22 | 76 | 60 | 120 | 40 | 170 | 41 | 125 | 16 | 36 | 8,4 | HRT080AF |
| 100 | 26 | 95 | 75 | 140 | 50 | 210 | 51 | 160 | 20 | 36 | 8,4 | HRT100AF |
| 125 | 33 | 112 | 85 | 177 | 63 | 265 | 61 | 200 | 25 | 50 | 11,4 | HRT125AF |
| 160 | 39 | 140 | 112 | 220 | 80 | 325 | 81 | 250 | 31 | 50 | 11,4 | HRT160AF |