

Serie HT

Cilindros Hidráulicos ISO 6020/2

Accesorios de fijación

Muñón Intermedio ISO MT4

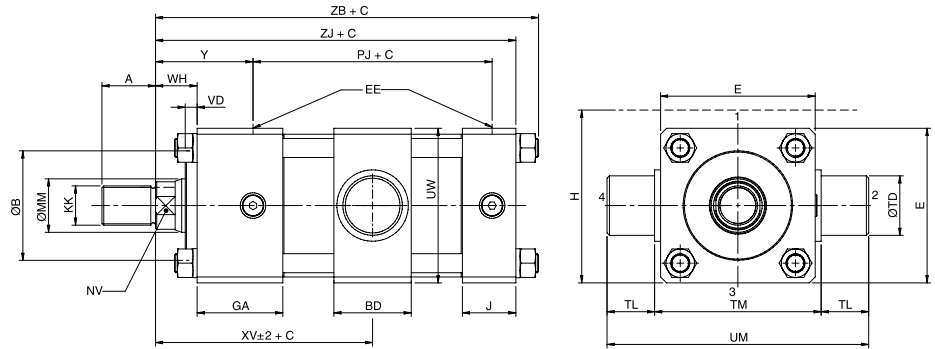
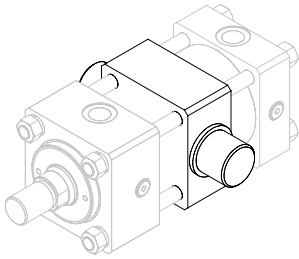

Ø	ØMM	A	B	BD	E	EE	GA	H	J	KK	NV	PJ	TD	TL	TM	UM	UW	VD	WH	XV _(min)	Y	ZB	ZJ	
25	12	14	24	20	40	1/4"G	50	45	25	M10x1,25	10	53	12	10	48	68	45	6	15	77	50	121	114	
	18	14	30							M10x1,25	15													M14x1,5
32	14	16	26	25	45	1/4"G	50	50	25	M12x1,5	12	56	16	12	55	79	50	12	25	90	60	136	128	
	22	16	34							M12x1,5	18													M16x1,5
	18	18	30							M14x1,5	15													
40	18	18	30	30	63	3/8"G	55	38	38	M14x1,5	15	73	20	16	76	108	70	12	25	97	62	163	153	
	28	18	42							M14x1,5	22													M20x1,5
	22	22	34							M16x1,5	18													
50	22	22	34	40	75	1/2"G	61	38	38	M16x1,5	18	74	25	20	89	129	83	9	25	108	67	173	159	
	36	22	50							M16x1,5	30													M27x2
63	28	28	42	48	90	1/2"G	61	38	38	M20x1,5	22	80	32	25	100	150	94	13	32	119	71	182	168	
	45	28	60							M20x1,5	36													M33x2
	45	45	60							M27x2	30													
80	36	36	50	55	115	3/4"G	70	45	45	M27x2	30	93	40	32	127	191	118	9	31	131	77	209	190	
	56	36	72							M27x2	46													M42x2
	56	56	72							M42x2	46													
100	45	45	60	65	130	3/4"G	72	45	45	M33x2	36	101	50	40	140	220	128	10	35	142	82	222	203	
	70	45	88							M33x2	60													M48x2
	63	63	88							M42x2	46													
125	56	56	72	85	165	1"G	80	58	58	M42x2	46	117	63	50	178	278	168	10	35	160	86	257	232	
	90	56	108							M42x2	80													M64x3
160	70	63	88	105	205	1"G	83	58	58	M48x2	60	130	80	63	215	341	205	7	32	170	86	277	245	
	110	63	133							M48x2	100													M80x3
	95	95	133							M80x3	100													
200	90	85	108	125	245	1 1/4"G	101	76	76	M64x3	80	165	100	80	279	439	250	7	32	198	98	334	299	
	140	85	163							M64x3	80													M100x3
	112	112	163							M100x3	120													