

Hydraulic Dampers

Multi-talent in speed control

The hydraulic dampers are similar in appearance to the ACE industrial gas springs but are adjusted in the end position and work differently to the DVC family with individual speed adjusters for the push and pull direction. This provide users with the maximum flexibility.

Whether used as drive compensation or safety elements, the retraction and extension speed of these ACE solutions can always be precisely set. This means that the speed of movement can be controlled, synchronisation regulated in both directions and pivoting loads can be compensated. Depending on the model, the push and pull forces are between 30 and 40,000 N. These maintenance-free, ready-to-install products are available in body diameters of 12 to 70 mm and in stroke lengths up to 800 mm.



Hydraulic Dampers



DVC-32

Page 174

Adjustable, Without Free Travel

Individual speed adjustment in both directions

Cylinder speed controls, Absorption control, Finishing and processing centres



HBD-50 to HBD-85

Page 176

Adjustable, Without Free Travel

Regulation at the highest level

Sports equipment, Rehabilitation technology, Conveyor technology



HBS-28 to HBS-70

Page 180

Adjustable, Without Free Travel

Direction change backlash free linear motion regulation

Oscillation insulation, Chairlift impact control, Fairground rides, Cylinder speed controls



HB-12 to HB-70

Page 184

Adjustable

Linear motion control

Conveyor systems, Transport systems, Furniture industry, Locking systems

Door Dampers



TD, TDE

Page 191

Adjustable

The safe way to close doors

Lift doors, Automatic doors, Doors

Constant speed rates

Sensitive adjustment

High quality and long lifetime

Easy to mount



Adjustable, Without Free Travel

DVC-32

Hydraulic Dampers

Individual speed adjustment in both directions

Can be regulated separately in any stroke position: The hydraulic dampers in the DVC-32 model are the first model to have the ability to have the in and out speeds adjusted independently from the outside and therefore more precisely. With their individual adjustment segments for the push and pull direction as well as the double-sided action, these are suitable as safety or control elements.

The great number of mounting accessories makes assembly of these hydraulic dampers by ACE easier and allows these maintenance-free, ready-to-install and self-contained systems universally applicable. Qualitatively high grade, and at the same time simple to use; one of their uses is to absorb swinging loads.

These machine elements are used, for one, in the automotive sector and industrial applications as well as in mechanical engineering and the electronics industry.

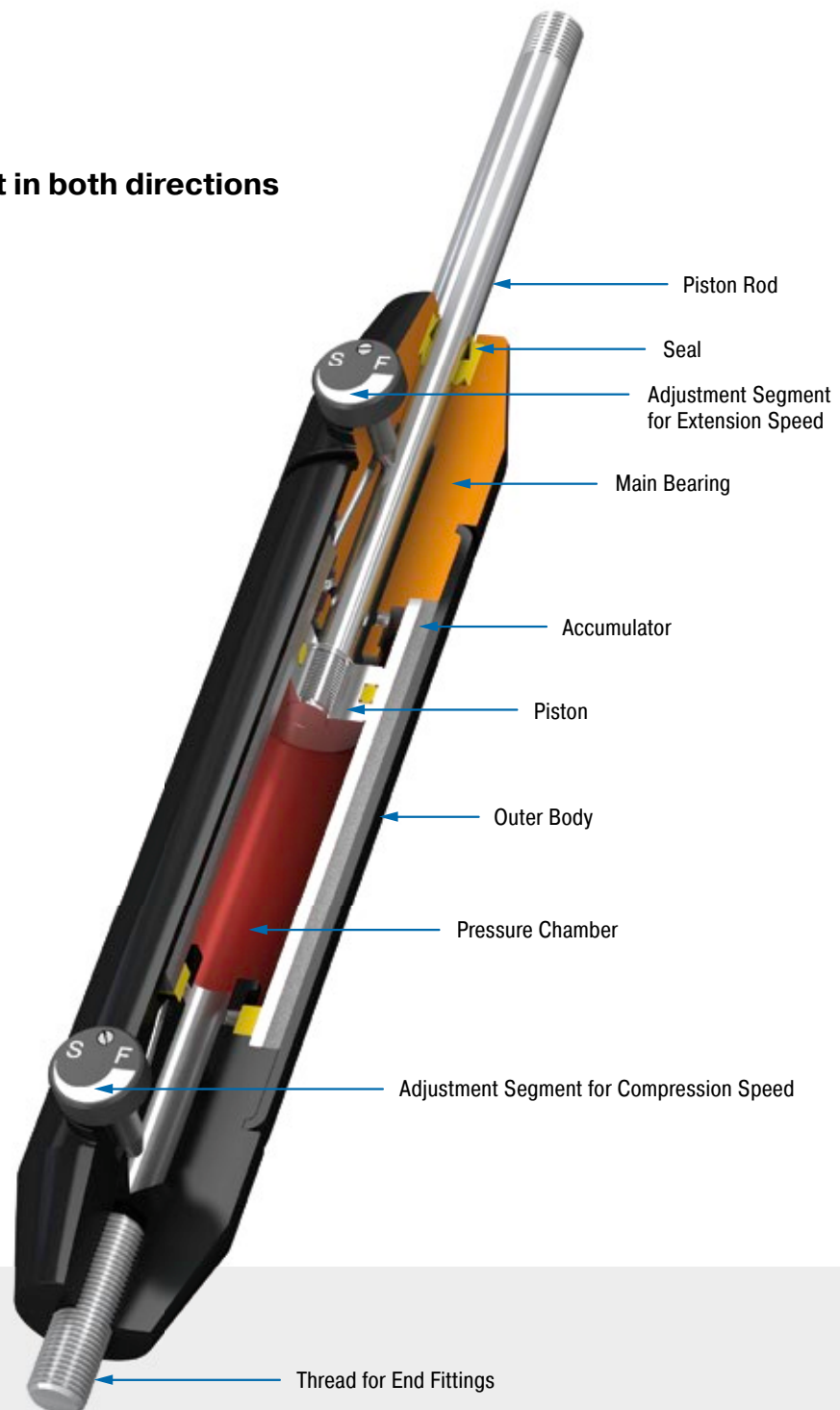

Technical Data

Compression and extension force:

42 N to 2,000 N

Outer body diameter: Ø 32 mm**Piston rod diameter:** Ø 8 mm**Lifetime:** Approx. 10,000 m**Operating temperature range:** 0 °C to 65 °C**Adjustment:** Steplessly adjustable**Positive stop:** External positive stops 1 mm to 1.5 mm before the end of stroke provided by the customer.**Damping medium:** Automatic Transmission Fluid (ATF)**Material:** Outer body: Coated aluminium; Piston rod: Black anodized aluminium; End fittings: Zinc plated steel**Mounting:** In any position**Application field:** Cylinder speed controls, Absorption control, Finishing and processing centres**Note:** Increased break-away force if unit has not moved for some time. Damping force can be adjusted after installation.**End fittings:** They are interchangeable and must be positively secured by the customer to prevent unscrewing.**On request:** Special oils and other special options. Alternative accessories available on request.

Adjustable, Without Free Travel, Compression and extension force 42 N to 2,000 N

End Fitting

Standard Dimensions

End Fitting

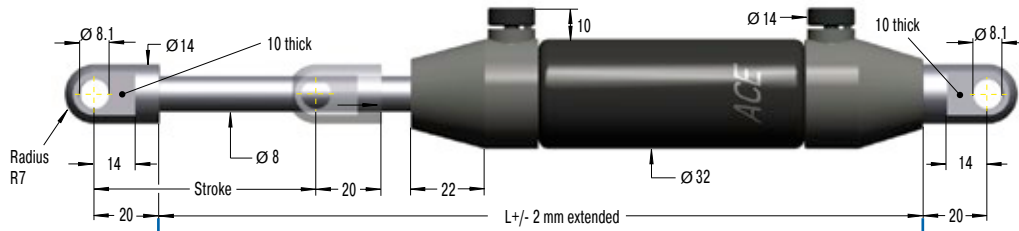
A8

Eye A8
max. force 3,000 N

B8

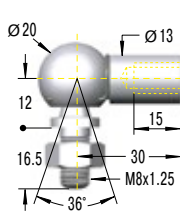

Performance and Dimensions

TYPES	Stroke mm	L extended mm	¹ Compression Force max. N
DVC-32-50EU	50	240	2,000
DVC-32-100EU	100	340	1,670
DVC-32-150EU	150	440	1,335

¹ Max. extension force for all stroke lengths 2,000 N.

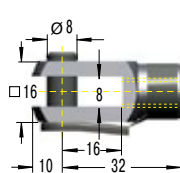
Stud Thread B8
C8

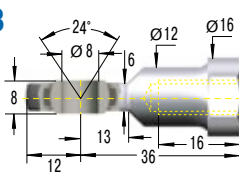
Angle Ball Joint C8
max. force 1,200 N

D8

Clevis Fork D8
max. force 3,000 N

E8

Swivel Eye E8
max. force 3,000 N

Ordering Example

DVC-32-50EU-DD-P

Type (Hydraulic Damper) _____
 Body Ø (32 mm) _____
 Stroke (50 mm) _____
 EU Compliant _____
 Piston Rod End Fitting D8 _____
 Body End Fitting D8 _____
 Damping Direction (P = both directions) _____

Model Type Prefix

P: Damping in both directions (standard model)
 M: Damping on out stroke only (adjustment knob at "rear end" free flow)
 N: Damping on in stroke only (adjustment knob at "piston rod end" free flow)

End fittings: They are interchangeable and must be positively secured by the customer to prevent unscrewing.

Mounting accessories see from page 194.

DVC-32EU-xx

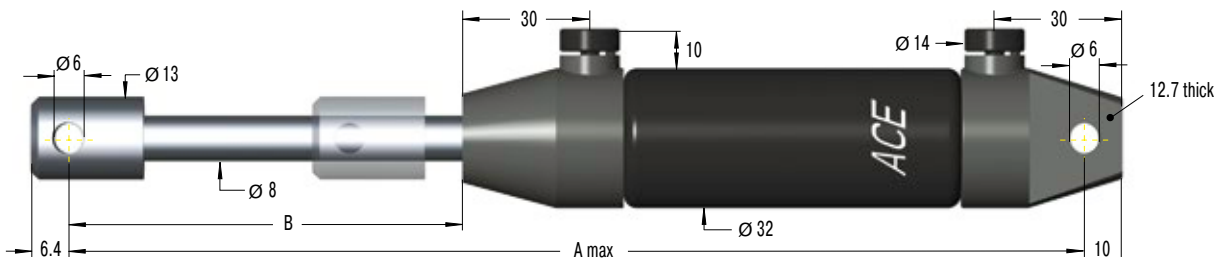

Performance and Dimensions

TYPES	Stroke mm	A max. mm	B mm	Compression Force max. N	Traction Force Range max. N
DVC-32-50EU-XX	50	250	75.2	2,000	2,000
DVC-32-100EU-XX	100	350	124.4	1,670	2,000
DVC-32-150EU-XX	150	450	173.6	1,335	2,000

Adjustable, Without Free Travel

HBD-50 to HBD-85 Hydraulic Dampers

Regulation at the highest level

Motion control in both directions: The HBD model of hydraulic dampers can be adjusted independently in both the push and pull direction. These maintenance-free, ready-to-install and closed systems leave no prayers unanswered as far as the setting of retraction and extension speeds are concerned. In addition each damper works without any free travel therefore the flow of oil can be regulated exactly via the two precision metering orifices.

Adjustment can be made once installed and even when moving through stroke. The coated body and hard-chromed piston rods stand for quality and long service life. The variety of mounting accessories makes assembly easy and the high-end hydraulic dampers universally usable.

HBD hydraulic dampers are used in the automotive, in industry, mechanical engineering and medical technology.

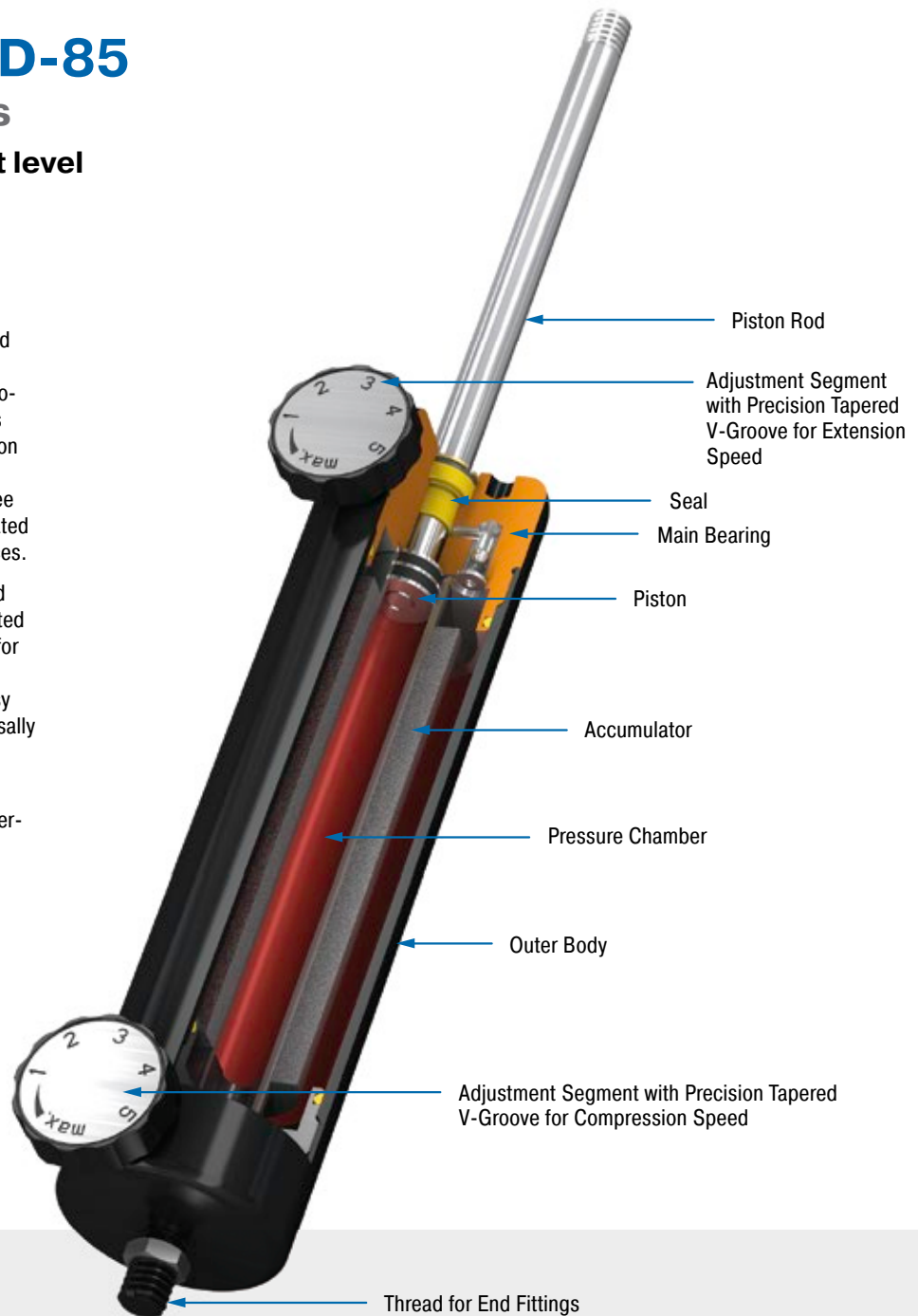

Technical Data

Compression and extension force:

150 N to 50,000 N

Outer body diameter: Ø 50 mm to Ø 85 mm

Piston rod diameter: Ø 10 mm to Ø 20 mm

Lifetime: Approx. 10,000 m

Operating temperature range: 0 °C to 65 °C

Adjustment: Steplessly adjustable

Positive stop: External positive stops 1 mm to 3 mm before the end of stroke provided by the customer.

Damping medium: Hydraulic oil

Material: Outer body: Coated steel; Piston rod: Hard chrome plated steel; End fittings: Zinc plated steel

Mounting: In any position

Application field: Sports equipment, Rehabilitation technology, Conveyor technology

Note: Increased break-away force if unit has not moved for some time. One locknut included.

End fittings: They are interchangeable and must be positively secured by the customer to prevent unscrewing.

On request: Special oils and other special options. Alternative accessories available on request.

Adjustable, Without Free Travel, Compression and extension force 100 N to 6,000 N

End Fitting

Standard Dimensions

End Fitting

B10

M10x1.5

Stroke

∅ 10

12

L +/- 2 mm extended

∅ 50

20

AF17

Performance and Dimensions

TYPES	Stroke mm	L extended mm	¹ Compression Force max. N
HBD-50-50	50	192	6,000
HBD-50-100	100	292	6,000
HBD-50-150	150	392	4,400
HBD-50-200	200	492	2,800
HBD-50-250	250	592	2,000
HBD-50-300	300	692	1,400

¹ Max. extension force for all stroke lengths 6,000 N.

Stud Thread B10

Eye A10
max. force 10,000 N

Angle Ball Joint C10
max. force 1,800 N

Clevis Fork D10
max. force 10,000 N

Swivel Eye E10
max. force 10,000 N

Ordering Example **HBD-50-150-EE**

Type (Hydraulic Damper) _____

Body ∅ (50 mm) _____

Stroke (150 mm) _____

Piston Rod End Fitting E10 _____

Body End Fitting E10 _____

Model Type Prefix

P: Damping in both directions (standard model)

M: Damping on out stroke only (adjustment knob at "rear end" free flow)

N: Damping on in stroke only (adjustment knob at "piston rod end" free flow)

Mounting accessories see from page 194.

Issue 08.2016 – Specifications subject to change

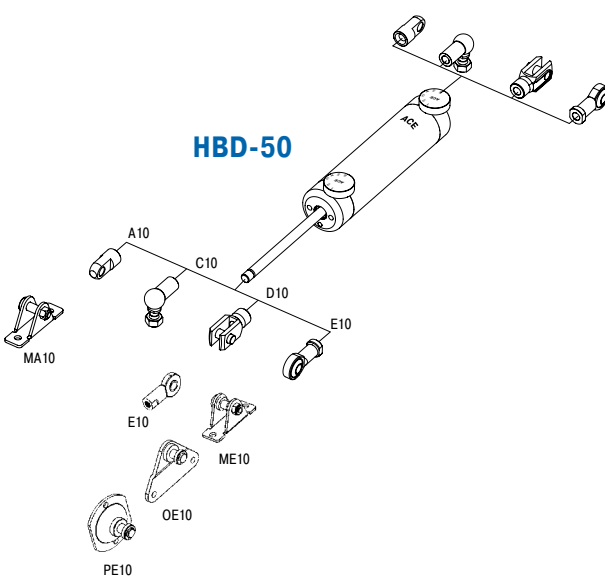

Technical Data

Compression and extension force: 100 N to 6,000 N

Operating temperature range: 0 °C to 65 °C

Adjustment: Steplessly adjustable

Positive stop: External positive stops 1 mm to 1.5 mm before the end of stroke provided by the customer.

Material: Outer body: Coated steel; Piston rod: Hard chrome plated steel; End fittings: Zinc plated steel

Mounting: In any position

Note: Increased break-away force if unit has not moved for some time. One locknut included.

End fittings: They are interchangeable and must be positively secured by the customer to prevent unscrewing.

Adjustable, Without Free Travel, Compression and extension force 150 N to 10,000 N

End Fitting

Standard Dimensions

End Fitting

B14 Stud Thread **B14**

A14 Eye **A14** max. force 10,000 N

C14 Angle Ball Joint **C14** max. force 3,200 N

D14 Clevis Fork **D14** max. force 10,000 N

E14 Swivel Eye **E14** max. force 10,000 N

Performance and Dimensions

TYPES	Stroke mm	L extended mm	¹ Compression Force max. N
HBD-70-100	100	314	10,000
HBD-70-150	150	414	10,000
HBD-70-200	200	514	10,000
HBD-70-300	300	714	10,000
HBD-70-400	400	914	8,000
HBD-70-500	500	1,114	6,000

¹ Max. extension force for all stroke lengths 10,000 N.

Ordering Example

HBD-70-300-EE

Type (Hydraulic Damper) _____

Body Ø (70 mm) _____

Stroke (300 mm) _____

Piston Rod End Fitting E14 _____

Body End Fitting E14 _____

Model Type Prefix

P: Damping in both directions (standard model)
 M: Damping on out stroke only (adjustment knob at "rear end" free flow)
 N: Damping on in stroke only (adjustment knob at "piston rod end" free flow)

Mounting accessories see from page 194.

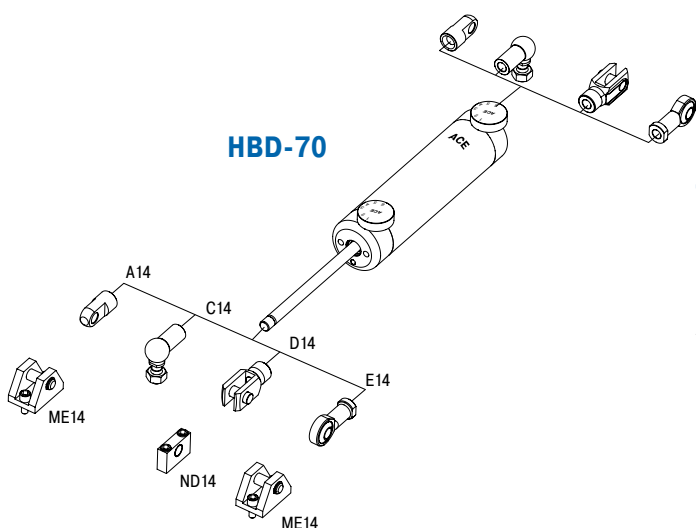

Technical Data

- Compression and extension force:** 150 N to 10,000 N
- Operating temperature range:** 0 °C to 65 °C
- Adjustment:** Steplessly adjustable
- Positive stop:** External positive stops 1 mm to 1.5 mm before the end of stroke provided by the customer.
- Material:** Outer body: Coated steel; Piston rod: Hard chrome plated steel; End fittings: Zinc plated steel
- Mounting:** In any position
- Note:** Increased break-away force if unit has not moved for some time. One locknut included.
- End fittings:** They are interchangeable and must be positively secured by the customer to prevent unscrewing.

Issue 08.2016 – Specifications subject to change

Adjustable, Without Free Travel, Compression and extension force 150 N to 50,000 N

End Fitting

Standard Dimensions

End Fitting

B24 M24x2 Thread Adaptor

D24 Clevis Fork D24 max. force 50,000 N

E24 Swivel Eye E24 max. force 50,000 N

Stroke: $\varnothing 20$

Body $\varnothing 85$

L +/- 2 mm extended

Dimensions: 28, 14, $\varnothing 46$, 17, 35, 35

Performance and Dimensions

TYPES	Stroke mm	L extended mm	¹ Compression Force max. N
HBD-85-100	100	313	50,000
HBD-85-150	150	413	30,000
HBD-85-200	200	513	20,000
HBD-85-300	300	713	10,000
HBD-85-400	400	913	6,500
HBD-85-500	500	1,113	4,000
HBD-85-600	600	1,313	3,000
HBD-85-700	700	1,513	2,000

¹ Max. extension force for all stroke lengths 50,000 N.

Ordering Example

HBD-85-300-EE

Type (Hydraulic Damper) _____

Body \varnothing (85 mm) _____

Stroke (300 mm) _____

Piston Rod End Fitting E24 _____

Body End Fitting E24 _____

Model Type Prefix

P: Damping in both directions (standard model)
 M: Damping on out stroke only (adjustment knob at "rear end" free flow)
 N: Damping on in stroke only (adjustment knob at "piston rod end" free flow)

Mounting accessories see from page 194.

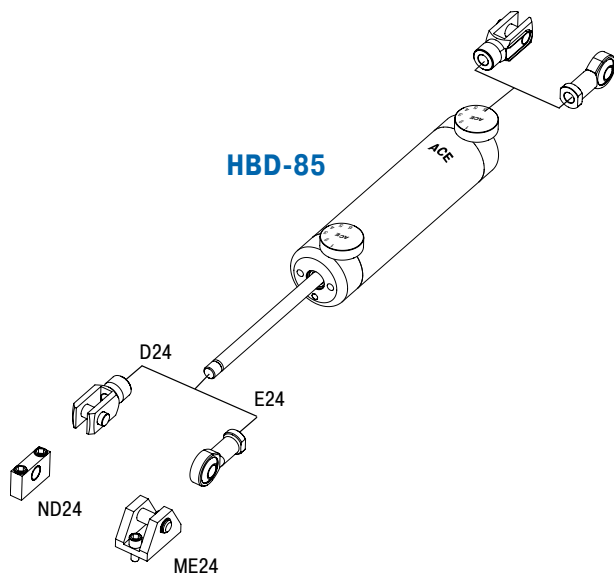

Technical Data

Compression and extension force: 150 N to 50,000 N

Operating temperature range: 0 °C to 65 °C

Adjustment: Steplessly adjustable

Positive stop: External positive stops 2 mm to 3 mm before the end of stroke provided by the customer.

Material: Outer body: Coated steel; Piston rod: Hard chrome plated steel; End fittings: Zinc plated steel

Mounting: In any position

Note: Increased break-away force if unit has not moved for some time. Thread adaptor for piston rod from M16 to M24 included.

End fittings: They are interchangeable and must be positively secured by the customer to prevent unscrewing.

HBS-28 to HBS-70

Hydraulic Dampers

Direction change backlash free linear motion regulation

Damping either in one or both directions: The HBS models of hydraulic dampers are made in a slim gas spring design and are compact and high in performance. Maintenance-free and ready-to-install they allow precise setting of retraction and extension speeds without any free travel when changing direction.

These hydraulic dampers offer constant feeding rates and can be finely tuned via the screw adjustment. A control segment on the piston makes the adjustment at the end position child's play. Thanks to many add-on components the assembly is easy to mount, so that the damper can be universally deployed for damping back and forth swinging masses, such as in power or free conveyors.

In addition to the automotive sector, the application areas are industrial applications, classic mechanical engineering, the electronics and furniture industry and medical technology.

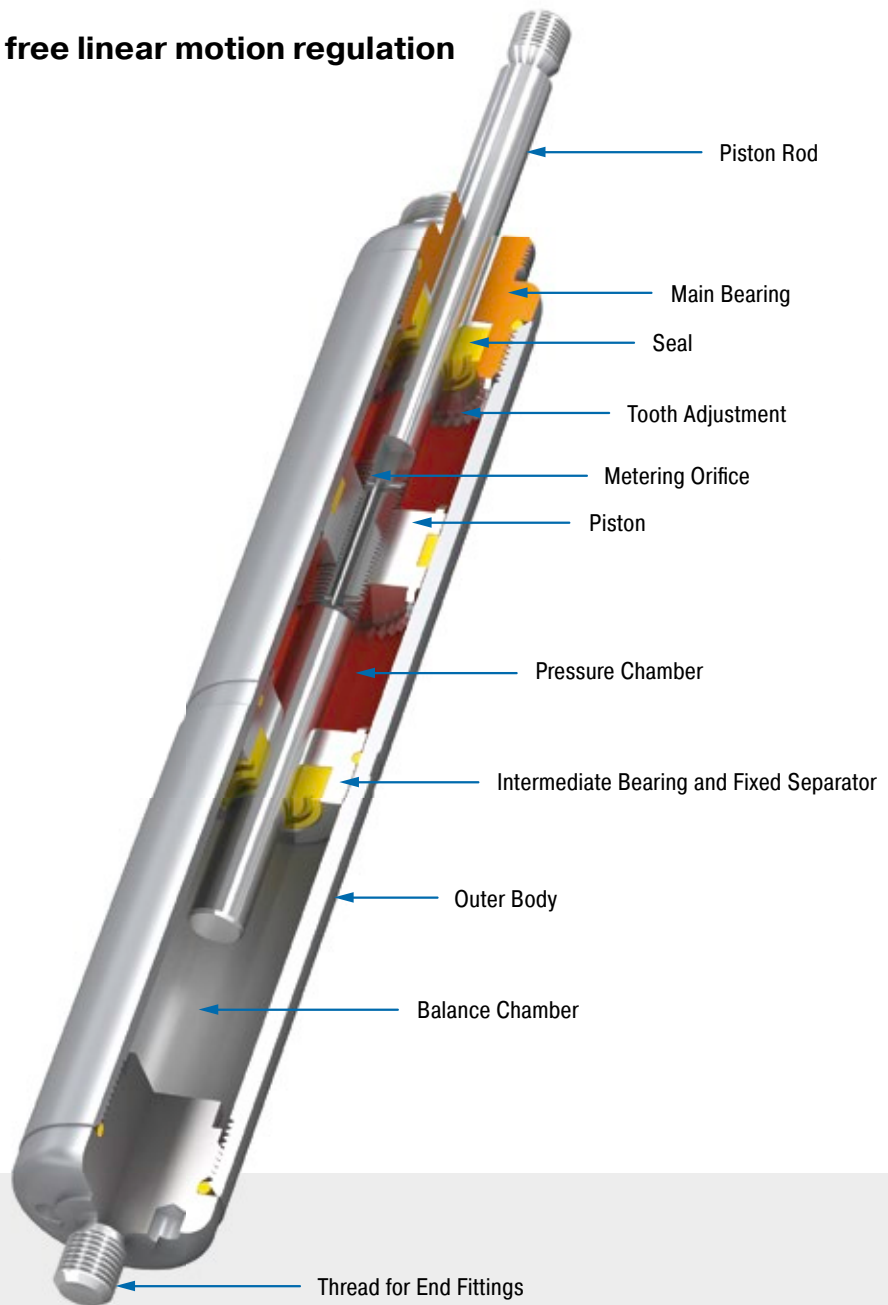

Technical Data

Compression and extension force:

30 N to 40,000 N

Outer body diameter: Ø 28 mm to Ø 70 mm

Piston rod diameter: Ø 8 mm to Ø 30 mm

Lifetime: Approx. 10,000 m

Operating temperature range: -20 °C to +80 °C

Adjustment: Achieved by turning the piston rod in its fully extended or compressed position.

Positive stop: External positive stops 1 mm to 6 mm before the end of stroke provided by the customer.

Damping medium: Hydraulic oil

Material: Outer body: Zinc plated or coated steel; Piston rod: Hard chrome plated steel; End fittings: Zinc plated steel

Mounting: In any position

Application field: Oscillation insulation, Chairlift impact control, Fairground rides, Cylinder speed controls

Note: Increased break-away force if unit has not moved for some time.

End fittings: They are interchangeable and must be positively secured by the customer to prevent unscrewing.

Safety instructions: For long strokes with high forces use swivel mounting block MBS.

On request: Special oils and other special options. Alternative accessories available on request.

Adjustable, Without Free Travel, Compression and extension force 30 N to 3,000 N

End Fitting

Standard Dimensions

End Fitting

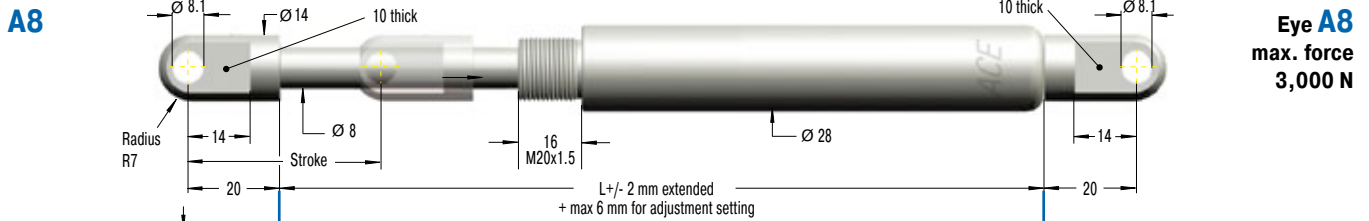

B8

C8

D8

E8

G8

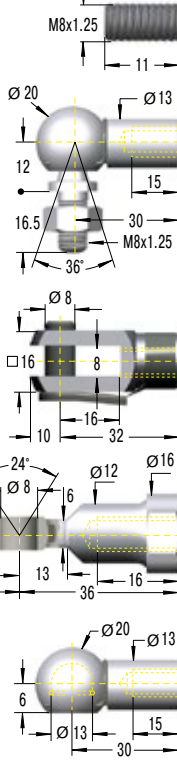

Performance and Dimensions

TYPES	Stroke mm	L extended mm	¹ Compression Force max. N	¹ Compression Force with MBS max. N
HBS-28-50	50	295	3,000	3,000
HBS-28-100	100	445	1,550	3,000
HBS-28-150	150	595	900	3,000
HBS-28-200	200	745	600	3,000
HBS-28-250	250	895	440	3,000
HBS-28-300	300	1,045	330	3,000
HBS-28-350	350	1,195	260	2,500
HBS-28-400	400	1,345	200	2,000

¹ Max. extension force for all stroke lengths 3,000 N.

Ordering Example

Type (Hydraulic Damper) **HBS-28-150-DD-M**
 Body Ø (28 mm) _____
 Stroke (150 mm) _____
 Piston Rod End Fitting D8 _____
 Body End Fitting D8 _____
 Damping Direction (M = out stroke only) _____

Model Type Prefix

P: Damping in both directions
 N: Damping on in stroke only
 M: Damping on out stroke only
 X: Special model suffix

Mounting accessories see from page 194.

Stud Thread B8

Angle Ball Joint C8 max. force 1,200 N

Clevis Fork D8 max. force 3,000 N

Swivel Eye E8 max. force 3,000 N

Ball Socket G8 max. force 1,200 N

Rod Shroud
no retrofit
Ø 32, L = Stroke + 50

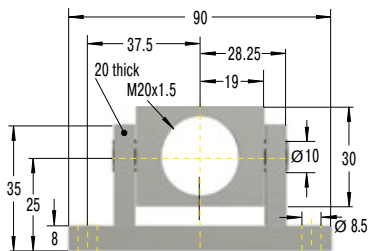

Swivel Mounting Block MBS-28

HBS-28

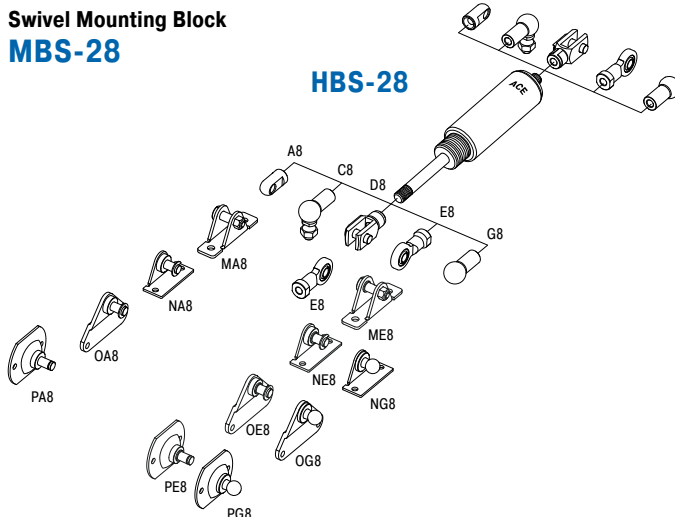

Technical Data

Compression and extension force: 30 N to 3,000 N

Operating temperature range: -20 °C to +80 °C

Adjustment: Achieved by turning the piston rod in its fully extended or fully compressed position.

Clockwise rotation = increase of the damping

Anti-clockwise rotation = decrease of the damping

Damping force adjustable before installation. The adjustment can add a max. of 6 mm to the L dimension.

Positive stop: External positive stops 1 mm to 1.5 mm before the end of stroke provided by the customer.

Material: Outer body: Zinc plated or coated steel; Piston rod: Hard chrome plated steel; End fittings: Zinc plated steel

Mounting: In any position

Note: Increased break-away force if unit has not moved for some time.

End fittings: They are interchangeable and must be positively secured by the customer to prevent unscrewing.

Safety instructions: For long strokes with high forces use swivel mounting block MBS.

Adjustable, Without Free Travel, Compression and extension force 30 N to 10,000 N

End Fitting

Standard Dimensions

End Fitting

A10

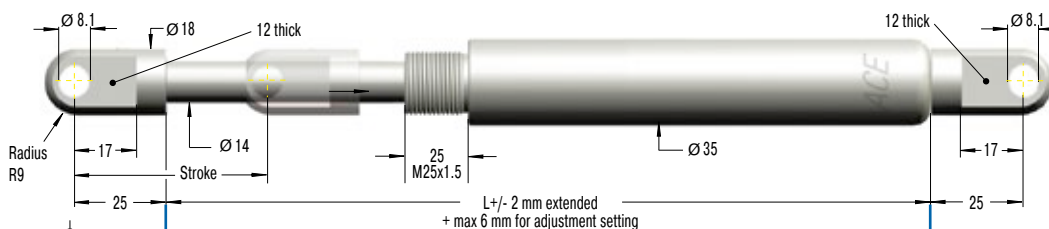

Eye A10
max. force
10,000 N

B10
C10

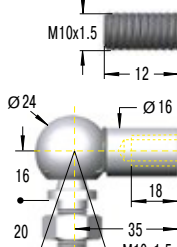

Stud Thread B10
Angle Ball Joint C10
max. force 1,800 N

D10

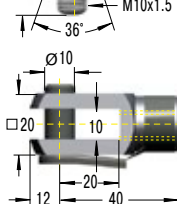

Clevis Fork D10
max. force 10,000 N

E10

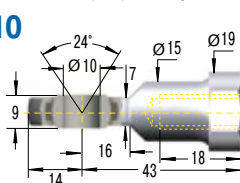

Swivel Eye E10
max. force 10,000 N

Performance and Dimensions

TYPES	Stroke mm	L extended mm	¹ Compression Force max. N	¹ Compression Force with MBS max. N
HBS-35-100	100	485	10,000	10,000
HBS-35-150	150	635	7,500	10,000
HBS-35-200	200	785	5,150	10,000
HBS-35-300	300	1,085	2,850	10,000
HBS-35-400	400	1,385	1,800	10,000
HBS-35-500	500	1,685	1,240	10,000
HBS-35-600	600	1,985	910	8,600
HBS-35-700	700	2,285	690	6,500
HBS-35-800	800	2,585	540	5,100

¹ Max. extension force for all stroke lengths 10,000 N.

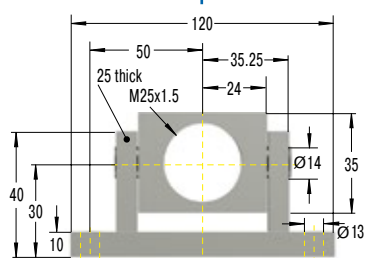
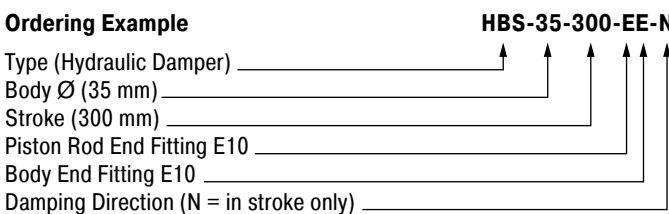

Swivel Mounting Block
MBS-35

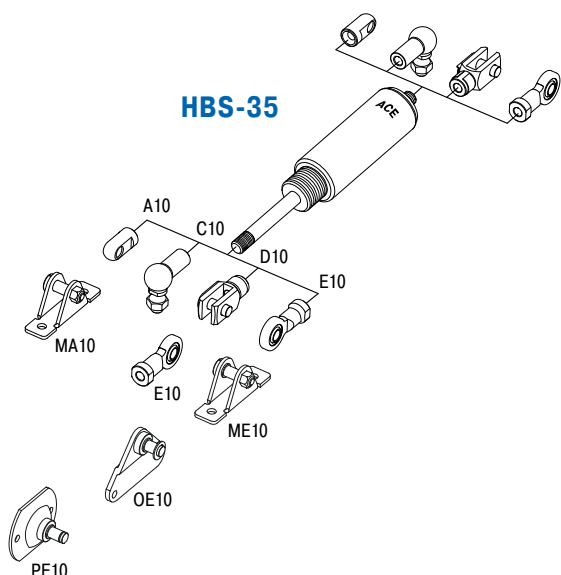

Model Type Prefix

- P: Damping in both directions
- N: Damping on in stroke only
- M: Damping on out stroke only
- X: Special model suffix

Mounting accessories see from page 194.

Technical Data

- Compression and extension force:** 30 N to 10,000 N
- Operating temperature range:** -20 °C to +80 °C
- Adjustment:** Achieved by turning the piston rod in its fully extended or fully compressed position.
Clockwise rotation = increase of the damping
Anti-clockwise rotation = decrease of the damping
Damping force adjustable before installation. The adjustment can add a max. of 6 mm to the L dimension.
- Positive stop:** External positive stops 1 mm to 1.5 mm before the end of stroke provided by the customer.
- Material:** Outer body: Zinc plated or coated steel; Piston rod: Hard chrome plated steel; End fittings: Zinc plated steel
- Mounting:** In any position
- Note:** Increased break-away force if unit has not moved for some time.
- End fittings:** They are interchangeable and must be positively secured by the customer to prevent unscrewing.
- Safety instructions:** For long strokes with high forces use swivel mounting block MBS.

Adjustable, Without Free Travel, Compression and extension force 2,000 N to 40,000 N

End Fitting

Standard Dimensions

End Fitting

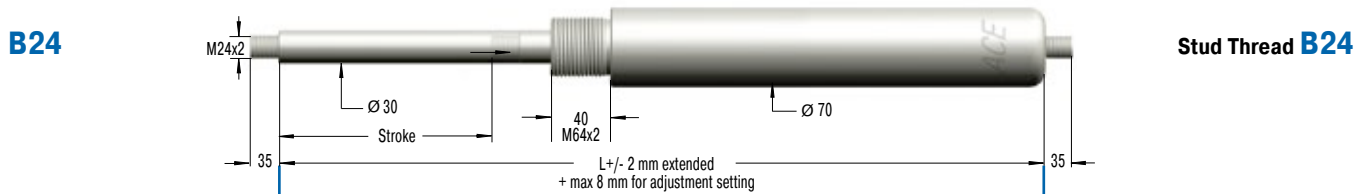

D24

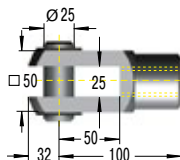

Clevis Fork **D24**
max. force 50,000 N

E24

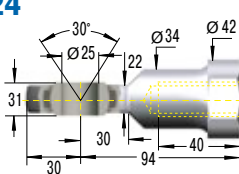

Swivel Eye **E24**
max. force 50,000 N

Performance and Dimensions

TYPES	Stroke mm	L extended mm	¹ Compression Force max. N	¹ Compression Force with MBS max. N
HBS-70-100	100	561	40,000	40,000
HBS-70-200	200	861	40,000	40,000
HBS-70-300	300	1,161	40,000	40,000
HBS-70-400	400	1,461	30,300	40,000
HBS-70-500	500	1,761	21,600	40,000
HBS-70-600	600	2,061	16,200	40,000
HBS-70-700	700	2,361	12,600	40,000
HBS-70-800	800	2,661	10,100	40,000

¹ Max. extension force for all stroke lengths 40,000 N.

Ordering Example

HBS-70-300-EE-N

Type (Hydraulic Damper) _____
 Body Ø (70 mm) _____
 Stroke (300 mm) _____
 Piston Rod End Fitting E24 _____
 Body End Fitting E24 _____
 Damping Direction (N = in stroke only) _____

Model Type Prefix

P: Damping in both directions
 N: Damping on in stroke only
 M: Damping on out stroke only
 X: Special model suffix

Mounting accessories see from page 194.

Rod Shroud **W24-70**
Ø 80, L = Stroke + 130

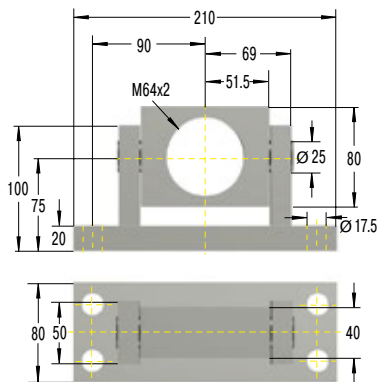

Swivel Mounting Block
MBS-70

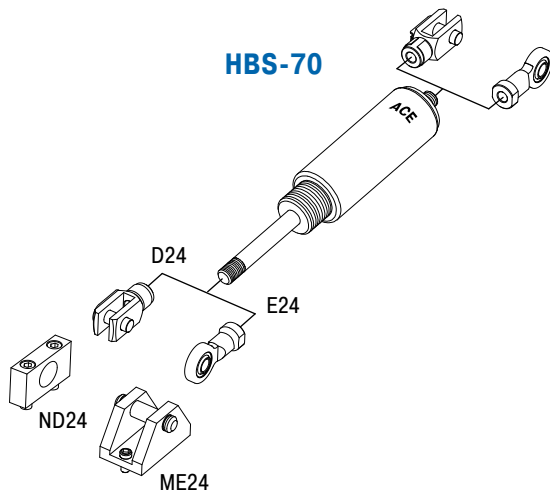

Technical Data

Compression and extension force: 2,000 N to 40,000 N

Operating temperature range: -20 °C to +80 °C

Adjustment: Achieved by turning the piston rod in its fully extended or fully compressed position.

Clockwise rotation = increase of the damping

Anti-clockwise rotation = decrease of the damping

Damping force adjustable before installation. The adjustment can add a max. of 8 mm to the L dimension.

Positive stop: External positive stops 5 mm to 6 mm before the end of stroke provided by the customer.

Material: Outer body: Zinc plated or coated steel; Piston rod: Hard chrome plated steel; End fittings: Zinc plated steel

Mounting: In any position

Note: Increased break-away force if unit has not moved for some time.

End fittings: They are interchangeable and must be positively secured by the customer to prevent unscrewing.

Safety instructions: For long strokes with high forces use swivel mounting block MBS.

Adjustable

HB-12 to HB-70 Hydraulic Dampers

Linear motion control

High quality and long service life: The HB model of hydraulic damper can also be used as single or double acting brake. Its coated body in a slim gas spring design and the piston rods with wear-resistant surface coating are features of high quality and long service life.

The maintenance free, ready-to-install and closed systems provide a constant feed rate and are adjustable, and the control segment on the piston makes adjustment at the end position child's play. Thanks to many add-on components the assembly is easy to mount, so that the damper can be universally deployed for damping back and forth swinging masses, such as in power or free conveyors.

On automotive or industrial applications, mechanical engineering, medical technology or the electronics and furniture industry, these machine elements are found in a number of different areas.

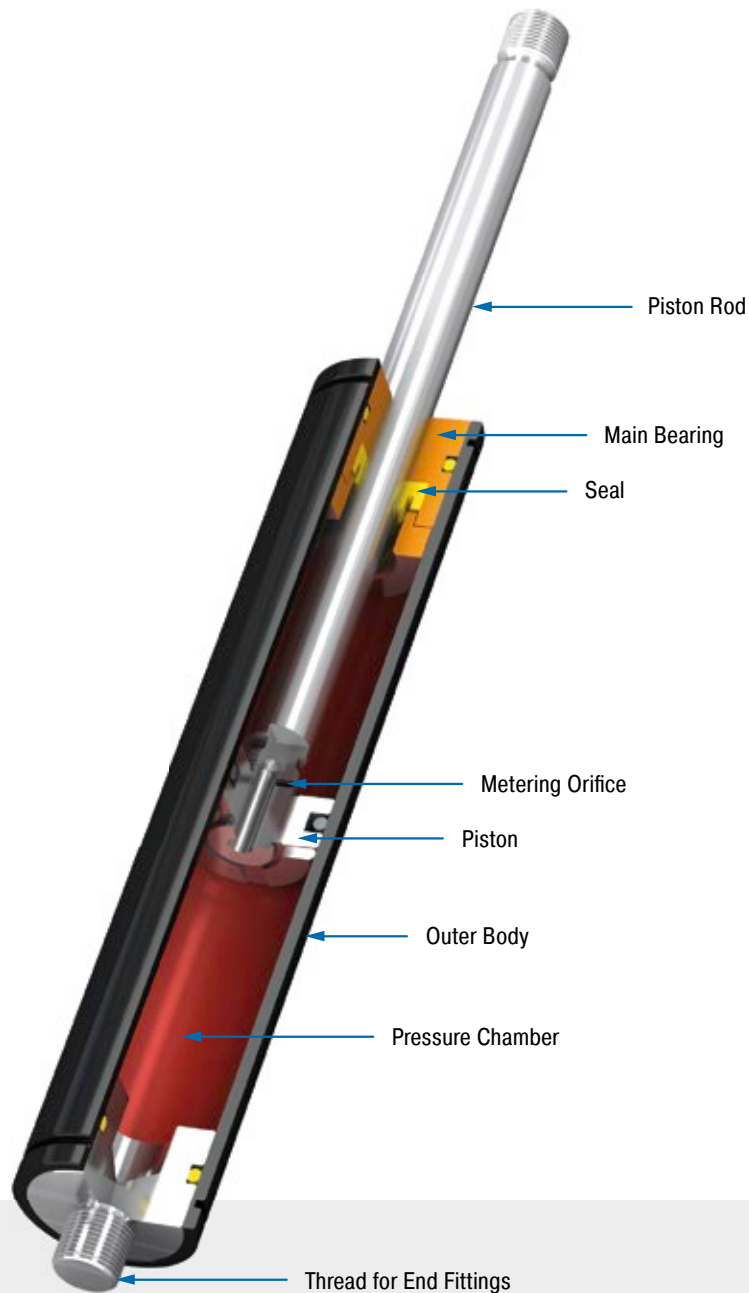

Technical Data

Compression and extension force:

20 N to 50,000 N

Outer body diameter: Ø 12 mm to Ø 70 mm

Piston rod diameter: Ø 4 mm to Ø 30 mm

Lifetime: Approx. 10,000 m

Free travel: Construction of the damper results in a free travel of approx. 20 % of stroke.

Separator piston: Available as a special option without free travel achieved by separator piston and nitrogen accumulator.

Operating temperature range: -20 °C to +80 °C

Adjustment: Achieved by turning the piston rod in its fully extended or fully compressed position.

Positive stop: External positive stops 1 mm to 6 mm before the end of stroke provided by the customer.

Damping medium: Hydraulic oil

Material: Outer body: Coated steel; Piston rod: Steel or stainless steel with wear-resistant coating; End fittings: Zinc plated steel

Mounting: In any position

Application field: Conveyor systems, Transport systems, Furniture industry, Locking systems

Note: Increased break-away force if unit has not moved for some time.

End fittings: They are interchangeable and must be positively secured by the customer to prevent unscrewing.

On request: Special oils and other special options. Alternative accessories available on request.

Adjustable, Compression and extension force 20 N to 180 N

End Fitting

Standard Dimensions

End Fitting

A3,5



Eye A3,5
max. force 370 N

B3,5

C3,5

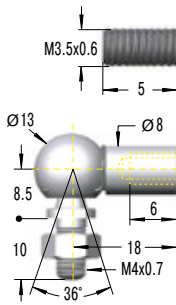

Performance and Dimensions

TYPES	Stroke mm	L extended mm	¹ Compression Force max. N
HB-12-10	10	55	180
HB-12-20	20	75	180
HB-12-30	30	95	180
HB-12-40	40	115	180
HB-12-50	50	135	180
HB-12-60	60	155	180
HB-12-70	70	175	180
HB-12-80	80	195	150

¹ Max. extension force for all stroke lengths 180 N.

D3,5

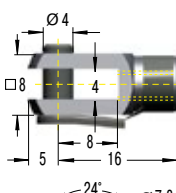

E3,5

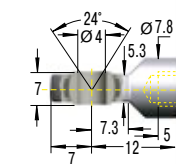

G3,5

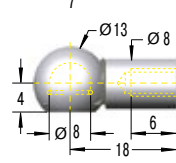

Rod Shroud W3,5-12

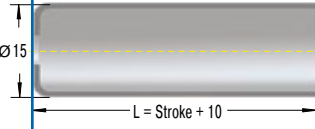

Ordering Example

HB-12-30-AC-M
 Type (Hydraulic Damper) _____
 Body Ø (12 mm) _____
 Stroke (30 mm) _____
 Piston Rod End Fitting A3,5 _____
 Body End Fitting C3,5 _____
 Damping Direction (M = out stroke only) _____

Model Type Prefix

P: Damping in both directions
 N: Damping on in stroke only
 M: Damping on out stroke only
 X: Special model suffix

Mounting accessories see from page 194.

Stud Thread B3,5

Angle Ball Joint C3,5
max. force 370 N

Clevis Fork D3,5
max. force 370 N

Swivel Eye E3,5
max. force 370 N

Ball Socket G3,5
max. force 370 N

Technical Data

Compression and extension force: 20 N to 180 N

Free travel: Construction of the damper results in a free travel of approx. 21 % of stroke.

Separator piston: -

Operating temperature range: -20 °C to +80 °C

Adjustment: Achieved by turning the piston rod in its fully extended or fully compressed position.

Clockwise rotation = increase of the damping

Anti-clockwise rotation = decrease of the damping.

The adjustment can add a max. of 6 mm to the L dimension.

Positive stop: External positive stops 1 mm to 1.5 mm before the end of stroke provided by the customer.

Material: Outer body: Coated steel; Piston rod: Stainless steel (1.4301/1.4305, AISI 304/303); End fittings: Zinc plated steel

Mounting: In any position

Note: Increased break-away force if unit has not moved for some time.

End fittings: They are interchangeable and must be positively secured by the customer to prevent unscrewing.

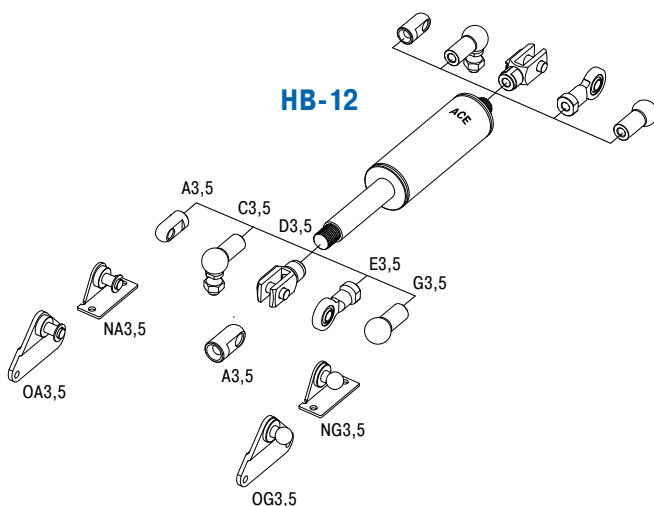

Adjustable, Compression and extension force 20 N to 800 N

End Fitting

Standard Dimensions

End Fitting

Performance and Dimensions

TYPES	Stroke mm	L extended mm	¹ Compression Force max. N
HB-15-25	25	93	800
HB-15-50	50	143	800
HB-15-75	75	193	800
HB-15-100	100	243	350
HB-15-150	150	343	300

¹ Max. extension force for all stroke lengths 800 N.

Ordering Example

HB-15-150-CC-M

Type (Hydraulic Damper) _____
 Body Ø (15.6 mm) _____
 Stroke (150 mm) _____
 Piston Rod End Fitting C5 _____
 Body End Fitting C5 _____
 Damping Direction (M = out stroke only) _____

Model Type Prefix

P: Damping in both directions
 N: Damping on in stroke only
 M: Damping on out stroke only
 X: Special model suffix

Mounting accessories see from page 194.

End Fitting Details:
 Eye A5: max. force 800 N
 Stud Thread B5
 Angle Ball Joint C5: max. force 500 N
 Clevis Fork D5: max. force 800 N
 Swivel Eye E5: max. force 800 N
 Ball Socket G5: max. force 500 N

Rod Shroud W5-15
 Ø19
 L = Stroke + 20

Technical Data

Compression and extension force: 20 N to 800 N

Free travel: Construction of the damper results in a free travel of approx. 20 % of stroke.

Separator piston: Extension force 40 N; dimension L = 2.45 x stroke + 49 mm. Part number: add suffix -T.

Operating temperature range: -20 °C to +80 °C

Adjustment: Achieved by turning the piston rod in its fully extended or fully compressed position.
 Clockwise rotation = increase of the damping.
 Anti-clockwise rotation = decrease of the damping.
 The adjustment can add a max. of 6 mm to the L dimension.

Positive stop: External positive stops 1 mm to 1.5 mm before the end of stroke provided by the customer.

Material: Outer body: Coated steel; Piston rod: Steel with wear-resistant coating; End fittings: Zinc plated steel

Mounting: In any position

Note: Increased break-away force if unit has not moved for some time.

End fittings: They are interchangeable and must be positively secured by the customer to prevent unscrewing.

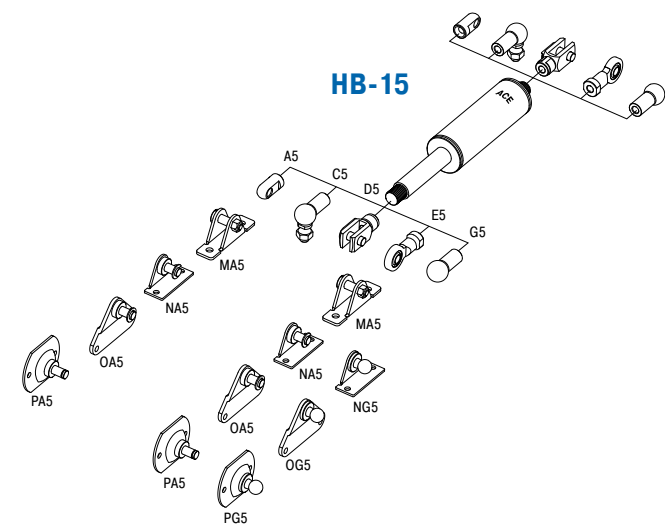

Issue 08.2016 – Specifications subject to change

Adjustable, Compression and extension force 30 N to 1,800 N

End Fitting

Standard Dimensions

End Fitting

End Fitting

A8 Eye A8 max. force 3,000 N

B8 Stud Thread B8

C8 Angle Ball Joint C8 max. force 1,200 N

D8 Clevis Fork D8 max. force 3,000 N

E8 Swivel Eye E8 max. force 3,000 N

G8 Ball Socket G8 max. force 1,200 N

Rod Shroud W8-22

Dimensions: $\varnothing 8.1$, $\varnothing 14$, 10 thick, Radius R7, 14, Stroke, $\varnothing 8$, $\varnothing 23$, 10 thick, $\varnothing 8.1$, 14, 20, L +/- 2 mm extended + max 6 mm for adjustment setting, 9, $\varnothing 20$, $\varnothing 13$, 12, 15, 16.5, 30, M8x1.25, 36°, $\varnothing 8$, 16, 8, 10, 16, 32, 24°, $\varnothing 8$, 6, 13, 16, 12, 6, $\varnothing 20$, $\varnothing 13$, 15, 30, $\varnothing 28$, L = Stroke + 30

Performance and Dimensions

TYPES	Stroke mm	L extended mm	¹ Compression Force max. N
HB-22-50	50	150	1,800
HB-22-100	100	250	1,800
HB-22-150	150	350	1,800
HB-22-200	200	450	1,000
HB-22-250	250	550	1,000

¹ Max. extension force for all stroke lengths 1,800 N.

Ordering Example

HB-22-150-DD-M

Type (Hydraulic Damper) _____
 Body \varnothing (23 mm) _____
 Stroke (150 mm) _____
 Piston Rod End Fitting D8 _____
 Body End Fitting D8 _____
 Damping Direction (M = out stroke only) _____

Model Type Prefix

P: Damping in both directions
 N: Damping on in stroke only
 M: Damping on out stroke only
 X: Special model suffix

Mounting accessories see from page 194.

Technical Data

Compression and extension force: 30 N to 1,800 N

Free travel: Construction of the damper results in a free travel of approx. 20 % of stroke.

Separator piston: Extension force 50 N; dimension L = 2.38 x stroke + 55 mm. Part number: add suffix -T.

Operating temperature range: -20 °C to +80 °C

Adjustment: Achieved by turning the piston rod in its fully extended or fully compressed position.

Clockwise rotation = increase of the damping
 Anti-clockwise rotation = decrease of the damping
 The adjustment can add a max. of 6 mm to the L dimension.

Positive stop: External positive stops 1 mm to 1.5 mm before the end of stroke provided by the customer.

Material: Outer body: Coated steel; Piston rod: Steel with wear-resistant coating; End fittings: Zinc plated steel

Mounting: In any position

Note: Increased break-away force if unit has not moved for some time.

End fittings: They are interchangeable and must be positively secured by the customer to prevent unscrewing.

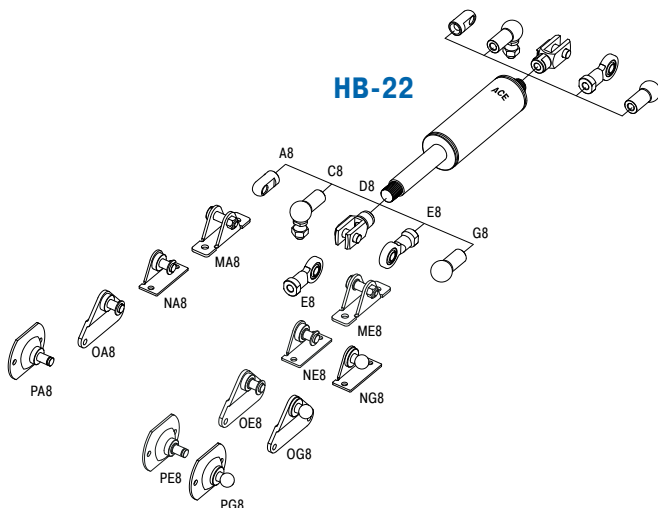

Adjustable, Compression and extension force 30 N to 3,000 N

End Fitting

Standard Dimensions

End Fitting

A8



Eye A8
max. force 3,000 N

B8



Performance and Dimensions

TYPES	Stroke mm	L extended mm	¹ Compression Force max. N
HB-28-100	100	260	3,000
HB-28-150	150	360	3,000
HB-28-200	200	460	3,000
HB-28-250	250	560	3,000
HB-28-300	300	660	2,500
HB-28-350	350	760	2,000
HB-28-400	400	860	1,500
HB-28-500	500	1,060	1,000

¹ Max. extension force for all stroke lengths 3,000 N.

Stud Thread B8

C8

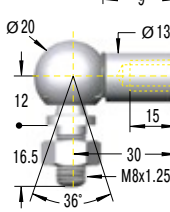

Angle Ball Joint C8
max. force 1,200 N

D8

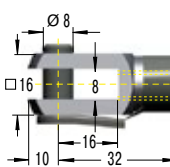

Clevis Fork D8
max. force 3,000 N

E8

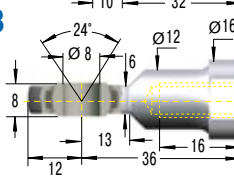

Swivel Eye E8
max. force 3,000 N

G8

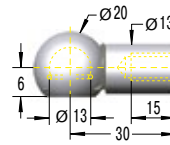

Ball Socket G8
max. force 1,200 N

Rod Shroud W8-28

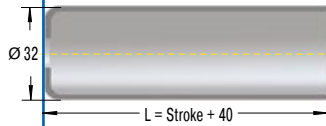

Ordering Example

Type (Hydraulic Damper) → HB-28-150-DD-M
 Body Ø (28 mm) →
 Stroke (150 mm) →
 Piston Rod End Fitting D8 →
 Body End Fitting D8 →
 Damping Direction (M = out stroke only) →

Model Type Prefix

P: Damping in both directions
 N: Damping on in stroke only
 M: Damping on out stroke only
 X: Special model suffix

Mounting accessories see from page 194.

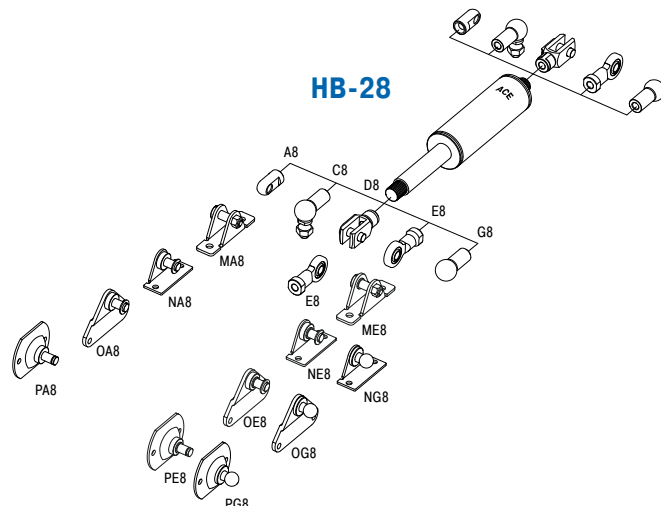

Technical Data

Compression and extension force: 30 N to 3,000 N

Free travel: Construction of the damper results in a free travel of approx. 20 % of stroke.

Separator piston: Extension force 80 N; dimension L = 2.35 x stroke + 60 mm. Part number: add suffix -T.

Operating temperature range: -20 °C to +80 °C

Adjustment: Achieved by turning the piston rod in its fully extended or fully compressed position.

Clockwise rotation = increase of the damping
 Anti-clockwise rotation = decrease of the damping
 The adjustment can add a max. of 6 mm to the L dimension.

Positive stop: External positive stops 1 mm to 1.5 mm before the end of stroke provided by the customer.

Material: Outer body: Coated steel; Piston rod: Steel with wear-resistant coating; End fittings: Zinc plated steel

Mounting: In any position

Note: Increased break-away force if unit has not moved for some time.

End fittings: They are interchangeable and must be positively secured by the customer to prevent unscrewing.

Adjustable, Compression and extension force 30 N to 10,000 N

End Fitting

Standard Dimensions

End Fitting

A14

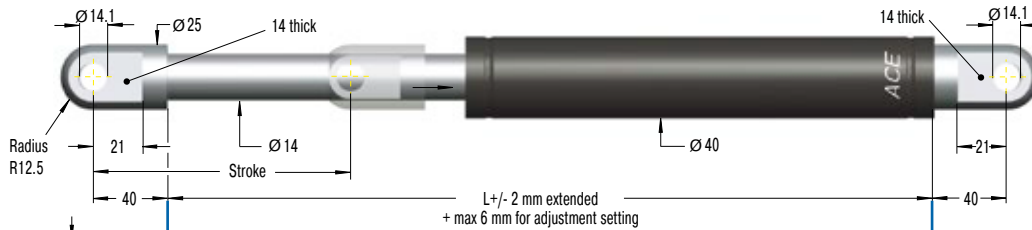

Eye A14
max. force 10,000 N

B14



Stud Thread B14

C14

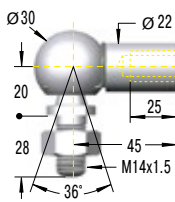

Angle Ball Joint C14
max. force 3,200 N

D14

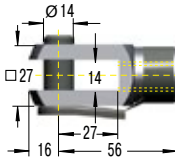

Clevis Fork D14
max. force 10,000 N

E14

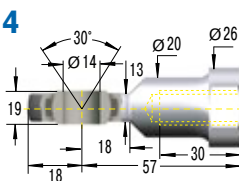

Swivel Eye E14
max. force 10,000 N

Rod Shroud W14-40

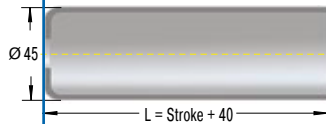

Performance and Dimensions

TYPES	Stroke mm	L extended mm	¹ Compression Force max. N
HB-40-100	100	275	10,000
HB-40-150	150	375	10,000
HB-40-200	200	475	10,000
HB-40-300	300	675	10,000
HB-40-400	400	875	8,000
HB-40-500	500	1,075	6,000
HB-40-600	600	1,275	4,000
HB-40-700	700	1,475	3,000
HB-40-800	800	1,675	3,000

¹ Max. extension force for all stroke lengths 10,000 N.

Ordering Example

Type (Hydraulic Damper) _____
 Body Ø (40 mm) _____
 Stroke (300 mm) _____
 Piston Rod End Fitting E14 _____
 Body End Fitting E14 _____
 Damping Direction (N = in stroke only) _____

HB-40-300-EE-N

Model Type Prefix

P: Damping in both directions
 N: Damping on in stroke only
 M: Damping on out stroke only
 X: Special model suffix

Mounting accessories see from page 194.

Technical Data

Compression and extension force: 30 N to 10,000 N

Free travel: Construction of the damper results in a free travel of approx. 20 % of stroke.

Separator piston: Extension force 150 N; dimension L = 2.32 x stroke + 82 mm. Part number: add suffix -T.

Operating temperature range: -20 °C to +80 °C

Adjustment: Achieved by turning the piston rod in its fully extended or fully compressed position.

Clockwise rotation = increase of the damping
 Anti-clockwise rotation = decrease of the damping
 The adjustment can add a max. of 6 mm to the L dimension.

Positive stop: External positive stops 1 mm to 1.5 mm before the end of stroke provided by the customer.

Material: Outer body: Coated steel; Piston rod: Steel with wear-resistant coating; End fittings: Zinc plated steel

Mounting: In any position

Note: Increased break-away force if unit has not moved for some time.

End fittings: They are interchangeable and must be positively secured by the customer to prevent unscrewing.

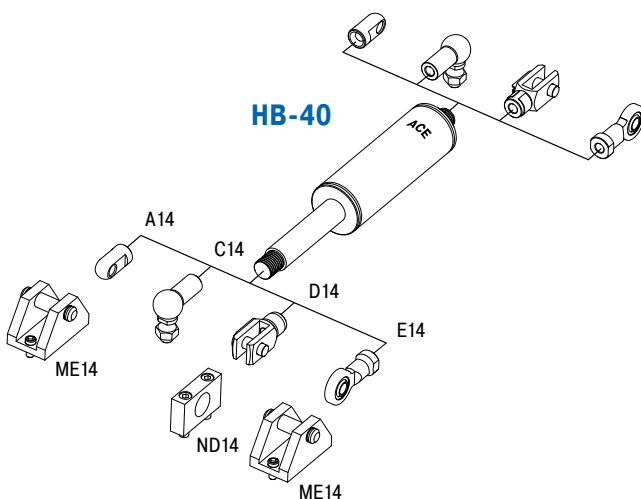

Adjustable, Compression and extension force 2,000 N to 50,000 N

End Fitting

Standard Dimensions

End Fitting

B24



Stud Thread B24

D24

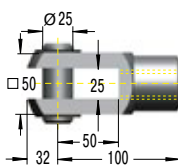

Clevis Fork D24
max. force 50,000 N

E24

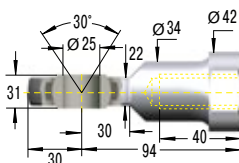

Swivel Eye E24
max. force 50,000 N

Performance and Dimensions

TYPES	Stroke mm	L extended mm	¹ Compression Force max. N
HB-70-100	100	320	50,000
HB-70-200	200	520	50,000
HB-70-300	300	720	50,000
HB-70-400	400	920	30,300
HB-70-500	500	1,120	21,600
HB-70-600	600	1,320	16,200
HB-70-700	700	1,520	12,600
HB-70-800	800	1,720	10,100

¹ Max. extension force for all stroke lengths 50,000 N.

Ordering Example

Type (Hydraulic Damper) **HB-70-300-EE-N**
 Body Ø (70 mm)
 Stroke (300 mm)
 Piston Rod End Fitting E24
 Body End Fitting E24
 Damping Direction (N = in stroke only)

Model Type Prefix

- P: Damping in both directions
- N: Damping on in stroke only
- M: Damping on out stroke only
- X: Special model suffix

Mounting accessories see from page 194.

Rod Shroud W24-70

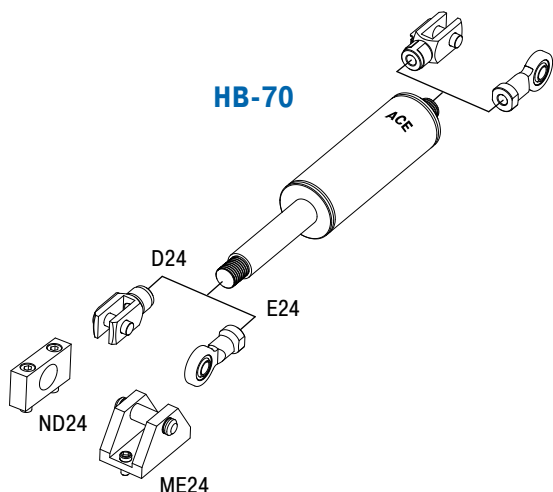
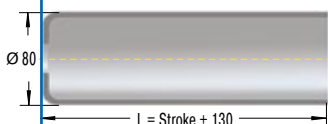

Technical Data

Compression and extension force: 2,000 N to 50,000 N

Free travel: Construction of the damper results in a free travel of approx. 20 % of stroke.

Separator piston: Extension force min. 250 N; dimension L + 150 mm. Part number: add suffix -T.

Operating temperature range: -20 °C to +80 °C

Adjustment: Achieved by turning the piston rod in its fully extended or fully compressed position.

Clockwise rotation = increase of the damping
 Anti-clockwise rotation = decrease of the damping
 The adjustment can add a max. of 8 mm to the L dimension.

Positive stop: External positive stops 5 mm to 6 mm before the end of stroke provided by the customer.

Material: Outer body: Coated steel; Piston rod: Hard chrome plated steel; End fittings: Zinc plated steel

Mounting: In any position

Note: Increased break-away force if unit has not moved for some time.

End fittings: They are interchangeable and must be positively secured by the customer to prevent unscrewing.

TD-28



Model Type Prefix

F: Automatic return with return spring
 D: Without return spring. When one piston is pushed in, the piston rod at the other end is pushed out (thus the damper must be impacted from alternate ends to sequence correctly).

Ordering Example

TD-28-50-50
 Type (Door Damper) _____
 Body Ø (28 mm) _____
 Stroke A (50 mm) _____
 Stroke B (50 mm) _____

Performance and Dimensions

TYPES	Energy Capacity Nm/cycle	Reacting Force N	Impact Mass max. kg	Stroke A mm	Stroke B mm	C mm	L extended mm	Return Force max. N	¹ Return Type
TD-28-50-50-F	75	1,550	150	50	50	220	402	30	F
TD-28-70-70-F	70	1,500	200	70	70	260	482	30	F
TD-28-100-100-F	80	1,500	250	100	100	220	502	40	F
TD-28-120-120-D	165	3,800	250	120	120	208	410	-	D

¹ Standard model. Other models available on request.

TDE-28

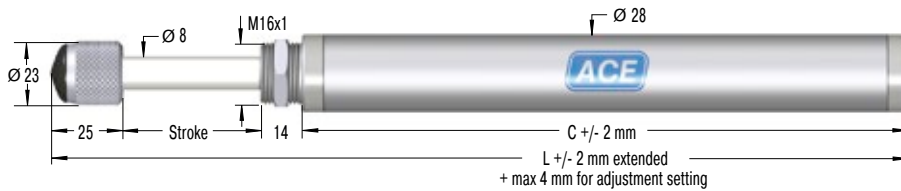

MB-16 Clamp Mount

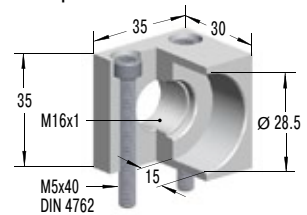

Ordering Example

TDE-28-50
 Type (Door Damper) _____
 Body Ø (28 mm) _____
 Stroke (50 mm) _____

Performance and Dimensions

TYPES	Energy Capacity Nm/cycle	Reacting Force N	Impact Mass max. kg	Stroke mm	C mm	L extended mm	Return Force max. N
TDE-28-50	80	2,400	4,000	50	130	221	30
TDE-28-70	112	2,400	5,600	70	158	269	30
TDE-28-100	160	2,400	8,000	100	193	333	30
TDE-28-120	190	2,400	7,000	120	214	373	40

Technical Data

Outer body diameter: Ø 28 mm

Piston rod diameter: Ø 8 mm

Free travel: TDE: Marginal

Operating temperature range: -20 °C to 80 °C

Adjustment: Pull the piston rod fully out and turn the knurled rod end button. The internal toothed adjustment allows the damping to be

separately adjusted for each side. As a result of the adjustment mechanism the overall length L can be increased by up to 4 mm.

Material: Outer body: Zinc plated steel; Piston rod: Hard chrome plated steel

Impact velocity range: 0.1 m/s to 2 m/s

Strokes per minute: Max. 10

Application field: Lift doors, Automatic doors, Doors

Note: ACE door dampers are single ended or double ended adjustable hydraulic shock absorbers.

On request: Special oils, other special options and special accessories are available on request.

Application Examples

DVC-32

Precise unreeling

Hydraulic dampers bring the sled movement of this textile machine to a gentle stop. At the turning point of 130 kg reeling spools, a sled should move up and down smoothly without causing a collision at the end of stroke position. The solution was provided by the hydraulic damper DVC-32-100EU. A self-contained sealed unit, ready to install and maintenance-free these units are ideal for precise control of speeds in both directions of travel. The travel speed is maintained throughout the entire stroke and can be independently adjusted in each direction of travel. Thanks to their compact design and wide choice of mounting accessories, these dampers could be easily integrated into this machine.

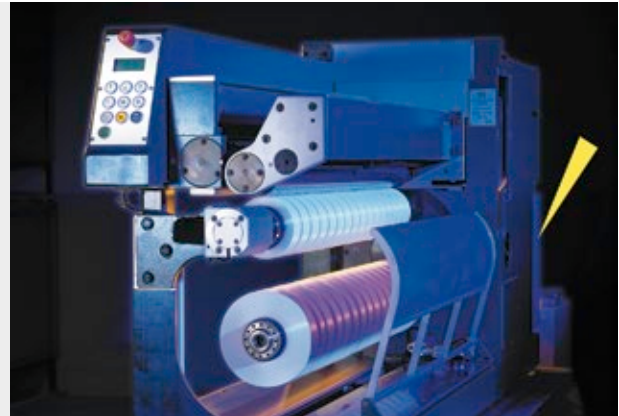
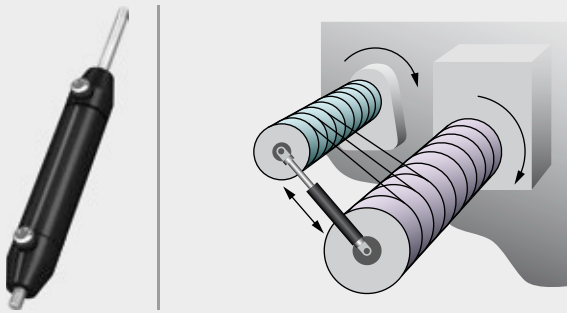

Textile machine unreels threads even better

HB-15

Operating speed of flaps top-regulated

In the past, operators of used-clothes containers could sustain injury because the flaps closed relatively quickly and uncontrollably. Various hydraulic dampers of the type HB-15, which are designed specifically for the type of container, regulate the synchronization of the flap in both directions and thereby serve to regulate the operating speed. To accommodate a range of requirements and to provide optimal protection against theft, different types with different strokes are mounted on flaps without damping, on large flaps with damping and on rotor flaps with damping.

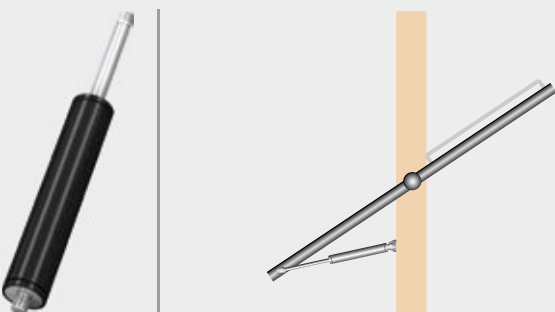

Hydraulic dampers prevent fingers becoming trapped in used-clothes containers as they ensure more gentle opening and closing movements
MCB Milieu & Techniek BV, 4704 SE Roosendaal, Netherlands

HB-40

Swinging movements cushioned by hydraulic dampers

Passengers always feel the swinging movement involved when cable cars arrive at the ski station. Maintenance-free hydraulic dampers type HB-40-300-EE-X-P cushion these movements perfectly. Designers of the cable cars, connected by means of an articulated joint via a four-point frame and connection guide to the suspension rod, profit from the ability of the adjustable dampers to absorb compressive forces of up to 10,000 N on either side.



Hydraulic dampers for added convenience when operating cable cars

